

EXAMINATION 4 (10:00 a.m.)

Circle your conference number:

- 1 (Iannacchione)      2 (Keil)                      3 (Colonna-Romano)      4 (Streletsky)  
5 (Jaspreson)              6 (Streletsky)

50-Minute Duration; Closed Book; Closed Notes.

The exam total is 100 points; the point total per part is indicated inside.

To be eligible for full credit, show all work on these pages. If you require more than one page for an answer, place the EXTRA WORK on the BACK of the PRECEDING PAGE -- the page facing the problem statement.

Write your name where indicated on each page of the exam.

Express answers to three significant figures, with UNITS. Draw a solid line (BOX) around all numerical answers.

$$g = 9.80 \text{ m/s}^2; \quad \Sigma \vec{F} = m\vec{a}; \quad \Sigma \tau = I\alpha$$

$$\omega = \frac{d\theta}{dt}, \quad \alpha = \frac{d\omega}{dt}; \quad v = R\omega, \quad s = R\theta$$

$$W_{TOT} = K_F - K_i$$

$$K = \frac{1}{2} m v^2 \text{ (translational)}$$

$$K = \frac{1}{2} I \omega^2 \text{ (rotational)}$$

For  $\alpha = \text{constant}$

$$\omega = \omega_0 + \alpha t$$

$$\theta = \theta_0 + \omega_0 t + \frac{1}{2} \alpha t^2$$

$$\omega^2 - \omega_0^2 = 2\alpha(\theta - \theta_0)$$

$$K_i + mgh_i + W_{\text{other}} = K_f + mgh_f$$

$$I = \Sigma m_n r_n^2$$

$$I = MR^2 \text{ (point mass + hoop)}$$

$$I = \frac{1}{2} MR^2 \text{ (disk)}$$

$$I = \frac{1}{3} ML^2 \text{ (stick about one end)}$$

$$L = I\omega \text{ (rotating object)}$$

$$L = mvr_{\perp} \text{ (point mass in translation)}$$

$$L_i = L_f \text{ (if no net ext. torques)}$$

1	
2	
Total	

PH 1110; A98; Exam 4a

Last Name \_\_\_\_\_

(20 pts) PROBLEM 1A.

A uniform beam of length  $L = 4.00$  m and weight  $m_1g = 500$  N supports a weight  $m_2g = 900$  N at one end. The beam is held in equilibrium by a hinge at one end and a guy wire in the middle, as shown.

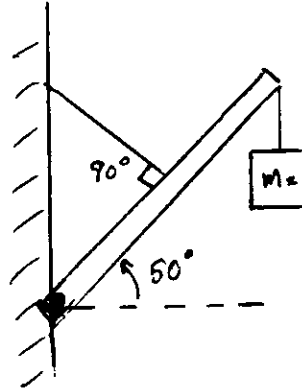

- a) Draw a free-body diagram for the beam, showing all forces acting on it. Label each force with an appropriate symbol.

- b) By application of the conditions of equilibrium, write down specific equations that will allow determination of all unknown forces acting on the beam. Use the symbols, numbers, and angles specified in the figure above and in your Part (a). DO NOT BOTHER TO SOLVE for the unknowns!!!

(30 pts) PROBLEM 1B.

A disk free to rotate about a fixed, frictionless, horizontal axle has a radius  $R = 0.800$  m and an inner hub of radius  $R/2$ . Constant forces of magnitude  $F_1 = 2.00$  N and  $F_2 = 5.00$  N are applied to the disk as shown. The disk is released from rest at  $t = 0$ , and the forces act for a time duration of 4.00 s. The angular acceleration of the disk is measured to be  $0.600$   $\text{rad/s}^2$ .

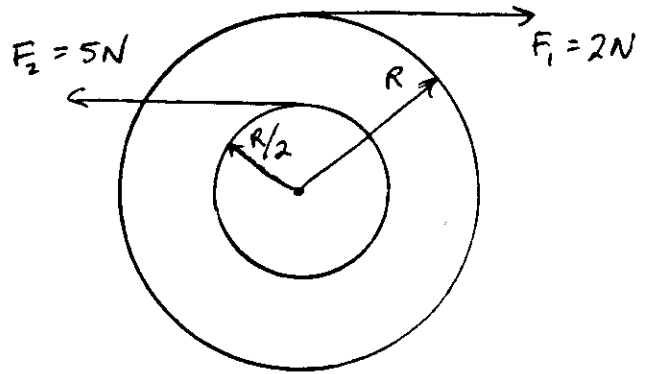

$$R = 0.800 \text{ m}$$

$$\omega_0 = 0$$

$$|\alpha| = 0.600 \frac{\text{rad}}{\text{s}^2}$$

a) Determine the moment of inertia  $I$  of the disk.

b) Calculate both the angular speed of the disk at the end of this time interval AND the angle through which it turns.

c) Calculate the work done on the disk by force  $F_1$  during this 4-sec interval.

PH 1110; A98; Exam 4a

(20 pts) PROBLEM 2A.

A uniform meter stick of mass  $m = 0.120$  kg and pivoted about a horizontal, frictionless axle located at one end of the stick, is released from a horizontal position at  $t = 0$  with an initial angular speed of  $3.00$  rad/s.

- a) Calculate the work done on the stick by the force of gravity as the stick swings freely down to the vertical position.

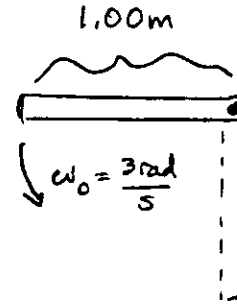

- b) Calculate the angular speed the stick has when it reaches the vertical.

(30 pts) PROBLEM 2B.

A large horizontal turntable of  $R = 4.00$  m and moment of inertia  $I_0 = 1200$  kg·m<sup>2</sup> is initially rotating with an angular speed  $\omega_0$ . A 90.0 kg person, initially hanging from a tree branch just above the turntable at a distance  $r = 2.00$  m from the rotation axis, drops straight down onto the surface and sticks to that point. After the person lands on the turntable, the whole system is observed to rotate CCW at an angular speed of 0.500 rad/s. (You are to treat the person as a point object.)

- a) Determine the rotational speed  $\omega_0$  of the turntable just before the person dropped onto its surface.

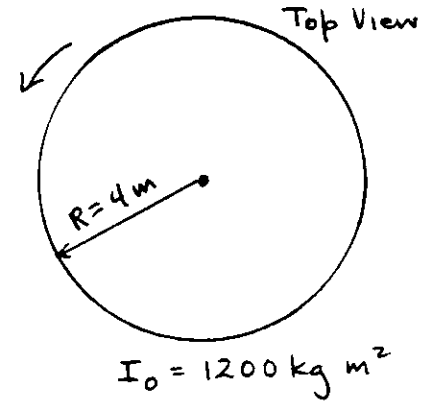

- b) The person now walks to a point on the turntable that makes the rotational speed as small as possible. State where this location is, and calculate the new angular speed of the turntable + person system.

- c) Calculate the work done on the turntable during the movement of the person described in Part (b).