

WPI Precision Personnel Locator System – Indoor Location Demonstrations and RF Design Improvements

Authors: D. Cyganski, *Member ION*; J. Duckworth, *Member ION*; S. Makarov, W. Michalson, *Member ION*; J. Orr, *Member ION*; V. Amendolare, J. Coyne, H. Daempfling, S. Kulkarni, H. Parikh, *Member ION*; B. Woodacre.
Electrical and Computer Engineering Department, Worcester Polytechnic Institute

BIOGRAPHY

Dr. David Cyganski is professor of Electrical and Computer Engineering at WPI where he performs research and teaches in the areas of linear and non-linear multidimensional signal processing, communications and computer networks, and supervises the WPI Convergent Technology Center. He is an active researcher in the areas of radar imaging, automatic target recognition, machine vision and protocols for computer networks. He is coauthor of the book *Information Technology: Inside and Outside*. Prior to joining the faculty at WPI he was an MTS at Bell Laboratories and has since held the administrative positions of Vice President of Information Systems and Vice Provost at WPI.

Dr. R. James Duckworth is an Associate Professor in the Electrical and Computer Engineering department at WPI. He obtained his PhD in parallel processing from the University of Nottingham in England. He joined WPI in 1987. Duckworth teaches undergraduate and graduate course in computer engineering focusing on microprocessor and digital system design, including using VHDL and Verilog for synthesis and modeling. His main research area is embedded system design. He is a senior member of the IEEE, and a member of the ION, IEE, and BCS and is a Chartered Engineer of the Engineering Council of the UK.

Dr. William R. Michalson is a Professor in the ECE Department at the WPI where he performs research and teaches in the areas of navigation, communications and computer system design. He supervises the WPI Center for Advanced Integrated Radio Navigation (CAIRN). His research focuses on the development, test, and evaluation of systems, which combine communications and navigation. He has been involved with navigation projects for both civilian and military applications with a special emphasis on navigation and communication techniques in indoor, underground or otherwise GPS-deprived situations. Prior to joining the faculty at WPI,

Dr. Michalson spent approximately 12 years at the Raytheon Company where he was involved with the development of embedded computers for guidance, communications and data processing systems for both space borne and terrestrial applications.

ABSTRACT

This paper describes the latest developments in the Worcester Polytechnic Institute (WPI) Precision Personnel Locator (PPL) project. The RF-based PPL system is being developed for tracking of first responders and other personnel in indoor environments. The system assumes no existing infrastructure, no pre-characterization of the area of operation and is designed for spectral compliance. This paper concentrates on describing the effects of different bandwidths on tracking and location accuracy in a variety of building structures based upon tests of the full system in those environments. The paper also documents the results of substantial improvements in the location algorithm. Recent testing has shown sub-meter positioning accuracy of a transmitter even in difficult indoor environments with high multi-path despite all receivers being placed outside the building.

The current system has demonstrated accuracies of approximately 0.5m in real building environments. Results to date have been achieved with a 60 MHz wide multi-carrier signal from 410 to 470 MHz. The RF transmitter and receiver hardware are currently being upgraded to allow operation in the 550 to 700 MHz region. A description and initial bench tests of the new RF hardware are included.

INTRODUCTION: WPI PRECISION PERSONNEL LOCATOR SYSTEM

This paper describes the outcomes of recent tests and new hardware enhancements of the Worcester Polytechnic Institute (WPI) Precision Personnel Locator (PPL) system which has been the subject of a series of papers tracking progress in this project [1-8].

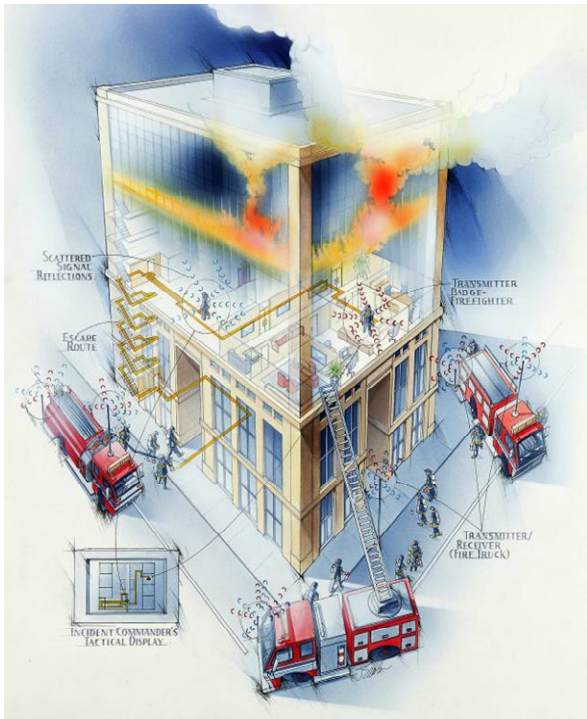

Fig. 1 Precision Personnel Locator system concept illustration.

Fig. 1 provides an overview of the envisioned precise personnel locator system being developed. The goal of the PPL system is to provide a robust real-time location tracking system which does not require any pre-existing infrastructure. Emergency vehicles and first responders would carry Multi Carrier – Wide Band (MC-WB) based transmitters. PPL equipped emergency vehicles arriving at the scene execute a calibration phase during which an ad hoc network and a relative coordinate system is established amongst the vehicle-fixed units. This relative position information may be optionally fixed to a known layout or to GPS reference coordinates.

Using the coordinates established by the vehicles, the signals received at the vehicles are then used to calculate the relative positions of personnel and/or equipment in and around the building.

The location of each first responder is then sent to a command and control display located at a command post base station which would display position information on its display console. This device displays the current position of all transmitters with respect either to the auto-generated coordinate system, or to a user preferred coordinate system. This may be registered to electronic building floor plans if such plans are available and/or may be GPS registered if GPS signals are available at the command console. The command console may also

provide other services such as displaying the tracks of all locators so that a map of available pathways in the building may be automatically generated by the movements of personnel and used in lieu of building plans to increase the commander's knowledge about the internal building structures and path obstructions on the fireground. Commanders can then apply this information for emergency-exit guidance and for assisting rescue of first responders in trouble.

The requirements for such a wireless personal tracking system are high accuracy (better than one meter) position location and tracking in 3 dimensions. In addition the system should provide; health and vital sign information, environment and temperature monitoring, be able to simultaneously track a minimum of 100 users, provide emergency exit guidance (back-tracking) and 'homing' signals [2].

Our location system is based upon a novel method developed by WPI for deployable operations-scale 3-D RF location. This zero-infrastructure, self-calibrating system tracks wearers of locator devices within buildings with respect to reference (receiver) units placed outside (or inside) buildings. The system design emphasizes low cost, size and weight, compatibility with FCC spectrum allocations, and simple, robust operation.

Any system which solves the 3-D location problem depends upon acquisition of distance fixes with respect to several reference points. In GPS the mobile units take a passive role, receiving signals transmitted by satellites with well known locations. In our approach, the mobile locator units are active, transmitting a signal which is received at the reference points. This approach is better suited to an interior environment, where GPS signal reception is very poor, and where a premium is placed on the low cost and low power drain of mobile units owing to the economic and logistic factors peculiar to first responder operations.

Alternative indoor geo-location approaches are various RFID, WiFi and Impulse UWB approaches, which exploit proximity, Received Signal Strength Indicator (RSSI) techniques and Time of Arrival techniques. Simple, short distance systems, such as based upon RFID technology have limited application as a universal solution owing to the need for pre-existing infrastructure to be installed in literally every room of every building – a logistics nightmare and economic impossibility. WiFi and RSSI techniques also depend upon, albeit less, previously installed equipment and calibrated infrastructure, but for precision application these also require extensive and costly calibration map surveys before they can be applied. These maps may be made obsolete by simply the act of moving or introducing new furniture. In addition, these infrastructure systems, owing to the number of

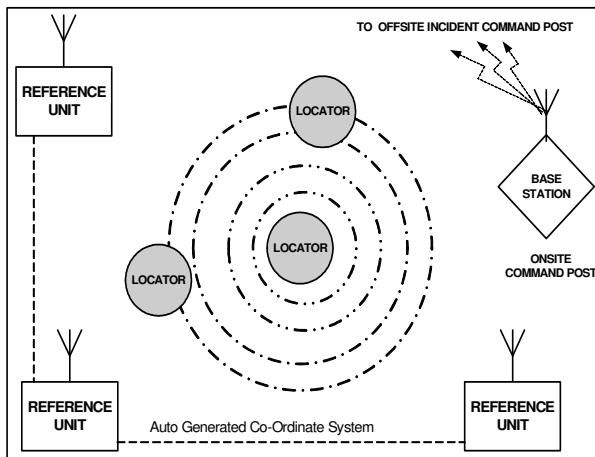

Fig. 2 PPL system overview.

components, require infrastructure power sources – since power may be lost in a fire, this ultimately means that back-up batteries and the logistics of maintaining city wide distributions of such batteries is implied. Finally, Impulse-UWB may require pre-installed infrastructure to obtain sufficient range. Overall, Impulse UWB is severely power and range limited (due to regulatory limitations and spectral compatibility problems).

System Architecture

The WPI PPL system consists of three components:

- Locator transmitters worn by each first responder or individual to be tracked;
- Reference Unit receivers that define the operational geometry and communicate with each other, the Locators, and the Base Station; and
- Incident commander’s Base Station which displays results in an operationally useful manner.

While Fig. 1 illustrates these pieces of equipment as they may be deployed in an operational environment, Fig. 2 provides a simplified depiction of the overall Precision Personnel Locator System architecture to support the following discussion. The system design (summarized below and in detail in [8]) enables the Locators to be small, and inexpensive to produce in large quantity. They transmit a repetitive broadband ranging signal as well as a narrowband identification and control signal. They also contain a data receiver for the control channel.

As indicated above, upon arrival at the incident site, reference units are placed near and around the location in which operations will take place. To perform 2D location three or more, and for 3D location, four or more receive points must be deployed. There are valuable gains in SNR and other contributing factors to be obtained from additional reference points. As was described in [8] we exploit an antenna multiplexing strategy that allows us to

reduce the cost and complexity of the system by limiting the number of receivers needed. These antennas and the supporting reference units may be mounted on several vehicles or can be deployed manually from one or more transport vehicles.

First responders will wear the mobile locator units which continuously transmit the MC-WB signals that are received by the reference units. Employing time difference of arrival (TDOA) techniques and a novel multi-lateralization algorithm to be described in a future paper, the reference units determine the position of the locator with respect to the auto-generated coordinate system.

Precision Location Approach

At the center of the RF precision indoor location problem is the means selected for precise ranging (distance estimation) between one or more base stations and a mobile locator device. Similar ranging technology is the basis for GPS technology in which satellite base station transmitters permit establishment of the location of mobile receivers and is also applied in cell phone location systems in which tower located base-station receivers estimate the location of mobile hand-held cell phone transmitters. However, several factors which are particularly exacerbated in the indoor environment have obstructed direct application of past solutions which are familiar from these other applications: insufficient signal strength, lack of precision and small-difference multipath degradation.

The difficult multi-path problem can be ameliorated with ultra-wideband ranging signals, however spectrum non-compliance issues have limited the applicability of this solution – furthermore failure of simple pulse distortion models in actual through-building and multi-path propagation conditions presents a significant challenge as well. In contrast, work to date on the proof-of-concept system described here has demonstrated means to provide these capabilities within the bounds of practical constraints.

The WPI PPL system is based upon the use of a multi-carrier wideband signal, similar to that used in OFDM communications, such as DSL broadband, and super-resolution range estimation algorithms similar to those employed in advanced radar systems [2]. Multiple discrete carriers are combined to form a wideband signal. Super-resolution processing results in a system that has several especially noteworthy properties that distinguish it from both impulse based and spread spectrum based ultra-wideband systems. Each carrier has nominally zero bandwidth and hence may be woven in between channels of existing services without interference, providing significant levels of spectral compatibility. The smaller

overall bandwidth (compared to UWB) also reduces antenna complexity and size while increasing efficiency, and reduces the problems introduced by frequency dependence of the signal paths due to material properties in a building.

This signal structure and signal processing approach together provide for the simplicity of the mobile locator units which comprises a simple periodic signal transmitter with no time synchronization requirements. This simple structure translates into a very low cost and low power consumption unit. The reference receiver architecture also benefits, as this moderate bandwidth signal structure allows a simplified “software-radio” implementation architecture that is amenable to system-on-chip design. This implementation approach has already been beneficial in the prototype stage as it has allowed us to implement many experimental software and firmware upgrades with no change in hardware and will likewise permit maintenance upgrades in any future commercial realization.

Over the course of this project we have developed prototypes that have generated the OFDM-like MC-WB ranging signal with a range of frequencies spanning bandwidths from 25 to 150 MHz. In all cases, the signal consists of N unmodulated sub-carriers spanning the bandwidth of operation B Hz, and (in the simplest implementation) spaced at B/N Hz. The regular spacing implied above is not necessary, and in fact these sub-carriers can be made to fall at arbitrary points in the spectrum chosen to avoid other-service interference and fulfill regulatory requirements without compromising the ranging technology we are using.

The moderate bandwidth requirements of the MC-WB signal also yields significant benefits with respect to antenna design. The current mobile transmitter unit exploits the benefits of compact patch antennas which can be tuned to admit the required bandwidth [8, 9, 10, 11].

Precise and multi-path compatible location is obtained by applying novel multi-carrier range recovery techniques derived in past work at WPI as described in [1, 3, 4, 7] based upon state space estimator approaches to modern spectral analysis first outlined in [12]. Fusion of these range outcomes was previously conducted by using standard multi-lateralization techniques [13] but has now been replaced by a new approach to be described in a future paper.



Fig. 3 The exterior view of the indoor test conducted in WPI's Kaven Hall. Base antennas surround building wing on three sides.



Fig. 4 The interior view of the WPI Kaven Hall test location.

PRECISION PERSONNEL LOCATOR SYSTEM TEST RESULTS

In a previous paper [8] we described the success of the current PPL system in a difficult indoor environment using a 60 MHz wide ranging signal centered at 440 MHz. In the following we first review this past result and then introduce several new results in additional difficult environments for comparison. In each case we demonstrate location performance of less than 1 meter of mean absolute error. All of these experiments involve locating a free-standing transmitter (battery powered with no cables to the rest of the system) inside a structure without any previous training or introduction of any information about the structure into the location system

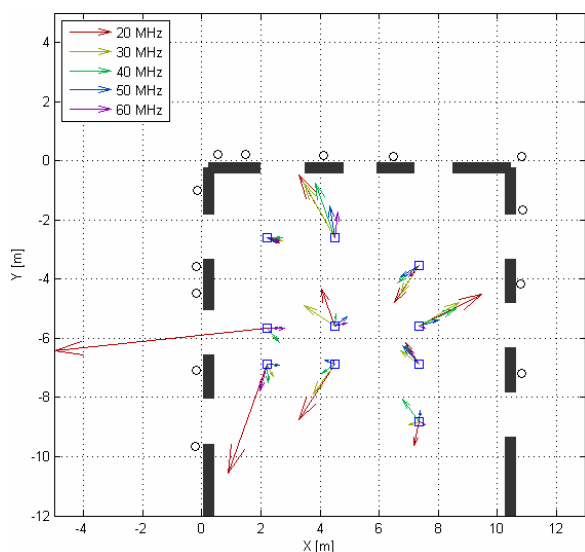

Fig. 5 Vectors indicate the difference between known transmitter locations and the estimates determined by the locator system as bandwidth is varied from 20 to 60 MHz.

In the first, and previously reported case, the transmitter was located within the brick and steel-beam building, known as Kaven Hall on the WPI campus, seen in Fig. 3

The receiving antennas were located outside the building and covered an approximate area of 20 m by 15 m. The room inside the building in which the transmitter was placed was used for laboratory experiments and had many metal benches, cabinets, ducts, conduits, machinery and other objects that would contribute to a high multipath environment. (Fig. 4)

The results documented here employed a 60 MHz wide multi-carrier signal in the 410 to 470 MHz band using linearly-polarized transmitting and receiving dipoles and a total radiated power of less than 10 mW as permitted by an experimental license granted by the FCC. This license permits both the use of greater bandwidth and a wider range of frequency bands for testing which we will exploit in our [150MHz wide system described later](#).

As seen in Fig. 3, thirteen antennas were placed around three sides of the Kaven Hall building. These antennas were placed immediately in front of the brick walls, with care to disallow any antenna from having a view of the inside of the building through a window. Throughout this run, the transmitter was placed at known positions at “chest height” above the floor of the laboratory room. This position placed the transmitter below the outside grade and under the plane of the receiving antennas. The positions of the antennas, wall structures and indications of window positions are shown in Fig. 5. This figure introduces error vectors for the purpose of indicating the

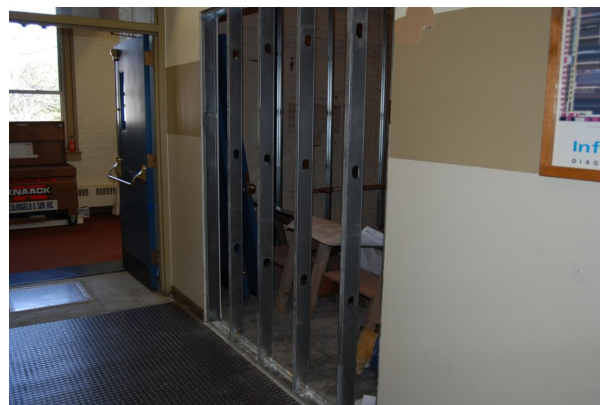

Fig. 6 Example of the 16 inch on-center steel stud based construction throughout the Atwater Kent building test location.

difference between the known transmitter positions and the estimated position obtained by the PPL system versus bandwidth. As mentioned earlier, the PPL system is uninformed with respect to the building structure and content – the information about the building was added manually later to this image to provide guidance for the interpretation of the results. While the locator system generates real time position estimates (approximately once every 2 seconds) all raw data is captured and saved so that results such as depicted in this figure, in which the bandwidth is varied by truncating the spectrum of the captured signal, can be generated.

As is clear from Fig. 5, increasing bandwidth translates into increased accuracy and increased immunity from outlier results due to multipath effects. With the full 60 MHz bandwidth applied, the average absolute distance error was 0.5 m versus 1 m at 30 MHz. This demonstrated improvement backs previous theoretical and simulation results and is the primary motivation for the design and implementation of a 150 MHz bandwidth version of this system which is described later in this paper.

A new experiment involved locating the free-standing transmitter inside another steel-structured building, WPI's Electrical and Computer Engineering Building, Atwater Kent, which possesses an internal wall structure and other radio propagation impediments that are particularly challenging to indoor location. This building has steel studs within its walls spaced 16 inches apart, as shown in Fig. 6. With our 440 MHz center frequency wavelength of 26.86 inches, this enclosure having a 0.6λ mesh spacing nearly comprises a Faraday cage. Furthermore, the walls of this area are hung with large metal backed blackboards, metal bookshelves, power panels, power distribution conduits and they feature metal fire doors and metal mesh embedded anti-theft windows. The ceiling of some of this building floor is formed from corrugated

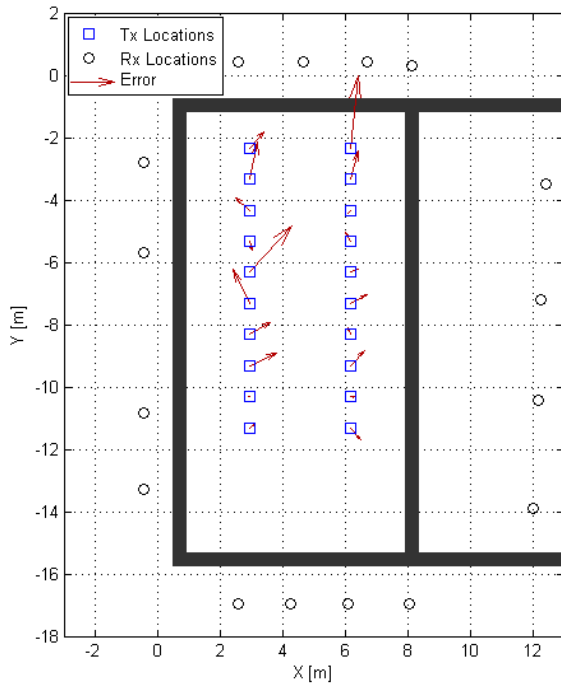

Fig. 7 Vectors indicate the difference between known transmitter locations and the estimates determined by the locator system in the Atwater Kent test.

metal sheet and each room is populated by metal pipe-style lab benches, long rows of fluorescent light fixtures and a typical assortment of engineering laboratory equipment.

Due to the difficulty of this multipath environment, our receive antennas were placed indoors in the hallways surrounding the core laboratory spaces, reducing the number of metal-studded walls to be penetrated to one. Sixteen receiver antennas were placed outside the laboratory. The transmit antenna was located inside a laboratory space (room AK317a) as shown in Fig. 7.

Fig. 7 shows the position estimation results for this location. This graphic indicates the location of our 16 receive antennas outside of the laboratory as well as the 20 transmitter locations inside the laboratory that were surveyed prior to the test to obtain “truth” data for



Fig. 8 Exterior view of WPI Religious Center test location.

comparison to the estimated locations. The graphic depicts the location estimation performance in the form of error vectors, which point from the true transmitter positions to the estimated positions. For this test the average absolute distance error was 0.71 meters. This is quite significantly better than the results of prior tests conducted with a 30 MHz bandwidth which yielded an average absolute error of nearly 2 meters.

We conducted another test at the WPI Religious Center, a two-story wooden, formerly residential, house shown in Fig. 8. While not as seemingly daunting, residential fires, owing to their larger numbers, lead to a significant number of fire fighter fatalities. According to a congressional testimony “Statistics also show that among all structure fires, it is those in residential homes that are most dangerous, accounting for over 70 percent of all fire deaths each year” [14].

While this testing location presented a less challenging multipath environment than the steel-structured Atwater Kent building, even wooden structure buildings contain significant amounts of metal plumbing, wiring, window frames/screens, appliances, fireplace and furnace ducts, etc., that contribute to the multipath environment.

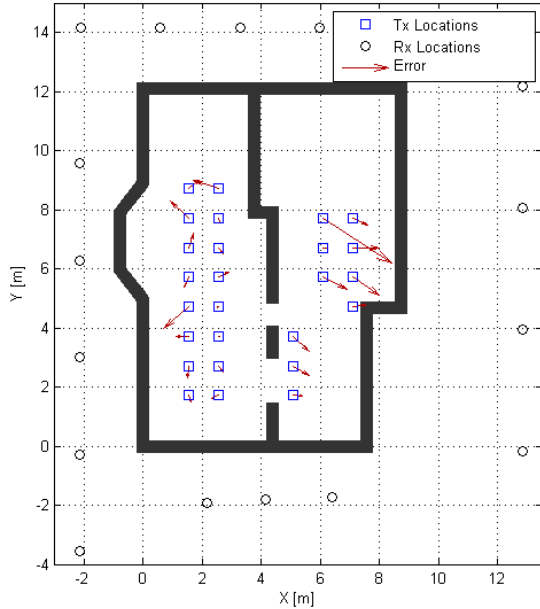

Fig. 9 Religious Center positioning results - first floor.

For this test our receiver antennas were all placed outside of the building, at the approximate height of the first floor. The transmitter was placed at various surveyed locations inside the house, both on the first and second floor. The position estimation results for the transmitter locations on the first floor, depicted in the same fashion as the previous results, are shown in Fig. 9. The average absolute distance error for these locations was 0.59 meters.

Fig. 10 graphically depicts the position estimation performance for transmitter locations on the second floor. This was a new challenge for our system since the transmitter was now approximately 3 meters higher than our receive antennas, a more difficult geometry. The average absolute distance error for these locations was 0.72 meters.

NEW 150MHZ WIDEBAND RF SYSTEM

The indoor wireless field test results presented above were based upon a 60 MHz wide ranging signal with multicarrier signals spanning the spectrum from 410 MHz to 470 MHz. As can be shown analytically and also dramatically demonstrated by the previous results, the multicarrier signal span plays a significant role in determining indoor position accuracy and robustness in the face of small path-difference multipath. As our current experimental license from the FCC also grants us permission for multicarrier transmissions from 512 MHz to 608 MHz and 614 MHz to 698 MHz, we decided to implement a 150MHz wide system capable of spanning

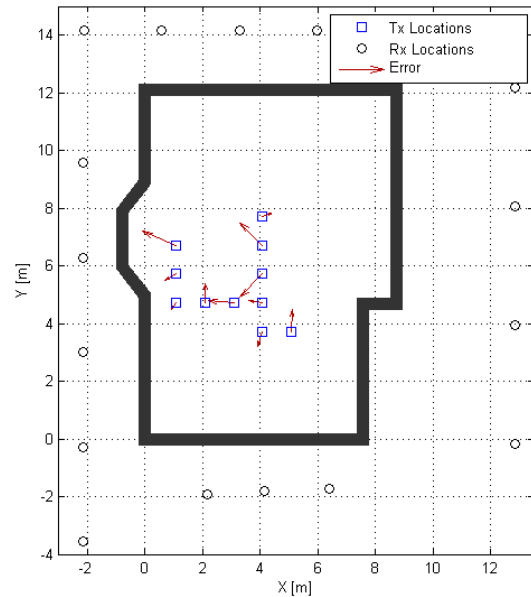

Fig. 10 Religious Center positioning results - second floor.

the spectrum from 550 MHz to 700 MHz. Exploitation of this new band and increased bandwidth required a substantial re-design of the RF and the digital hardware in the PPL prototype system.

One of the major imperfections, with performance implications, found in the original 60 MHz RF transmitter was that of poor frequency response flatness – the transmitted spectrum had an undesired 15 dB roll-off across its 60MHz span. Also, the maximum output power at the transmitter was limited to -15 dBm/SC, whereas higher transmission power levels are desirable to improve the systems positioning coverage area. Furthermore, the transmitter for the 60 MHz system was intended only as a proof of concept prototype and used an external PLL for the mixer LO and an external tubular BPF. Both of these design choices made for easy prototype reconfiguration, but also made the transmitter somewhat impractical to use in field testing. Hence, the new design also includes these modules on-board with all other RF components.

The re-design of the system also provided the opportunity to address several other issues that had arisen with respect to the existing 60 MHz RF transmitter. Power consumption is a concern at the transmitter owing to its mobility and need to operate without attention throughout an entire call to action. The new transmitter features a remote power shutdown capability that will be useful to conserve battery power before a firefighter enters the fire ground and after he/she temporarily leave it. In addition, better shielding of RF components would minimize inter-stage RF leakage and as a result reduce IMD (inter-modulation distortion). Similarly, for the 150MHz

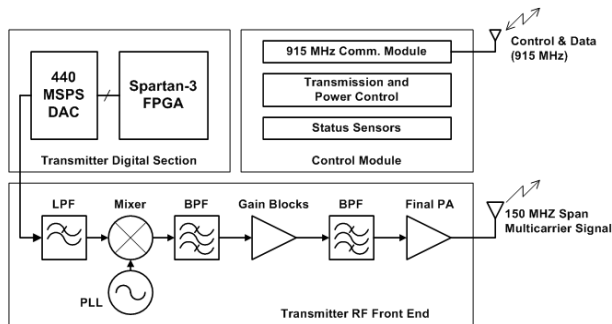

Fig. 11 The 150 MHz transmitter block diagram.

receiver design, improvements that were made include improved frequency response flatness, elimination of external RF components, provision for better RF shielding, and improvements to crucial aspects of receiver performance such as receiver sensitivity and dynamic range.

The next two sections discuss in greater depth the design and implementation of the new 150MHz RF transmitter and receiver.

150MHZ TRANSMITTER

The new transmitter block diagram is shown in Fig. 11. It consists of an RF front end, a digital section (that generates a baseband multi-carrier waveform with an FPGA and a DAC), and a low-power control and communications module for tasks such as power control, transmission coordination, and environmental and status data communication using a separate RF channel at 915 MHz. The DAC, running at 440 MHz, provides the baseband signal spanning the spectrum from 30 MHz to 180 MHz as shown in Fig. 12. As can be seen in the figure, the spectrum does not have to be continuous and can be easily modified to avoid forbidden areas (as is in fact necessitated by the gap between 608 and 614 MHz) and interference to and from other existing services such as TV signals in our current FCC spectral allocation.

The baseband signal spectrum at the DAC output shown in Fig. 12. This baseband signal is the input to the transmitter RF front end. The transmitter RF front end consists of Low Pass Filter (LPF), Up Conversion Mixer, Gain Block, Power Amplifier (PA) and Band Pass Filter (BPF). The Low Pass Filter is realized by a 7th order elliptical LC filter, providing the sharp roll off required to eliminate the DAC sampling-induced aliased signal component. The LPF has the advantages of an LC design, that is, low insertion loss, high power handling and flexible design.

A high performance passive mixer is used to implement the up-converter. The mixer has wide bandwidth on all

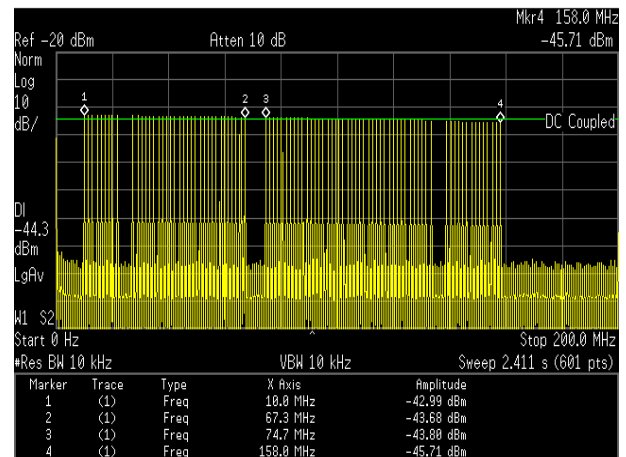

Fig. 12 Spectrum of the baseband signal at the DAC output in the 150 MHz transmitter.

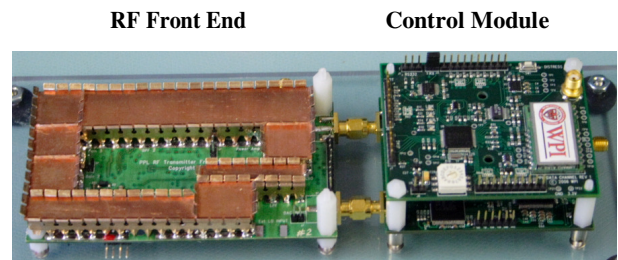

Fig. 13 Transmitter RF and digital waveform generator PCB.

its ports, very low intermodulation distortion, and good LO-RF rejection. The mixer used in the transmitter is suitable for high intercept point applications.

An onboard RF PLL (phase locked loop) frequency synthesizer is used to generate the required mixer local oscillator signal. The complete PLL is implemented on the bottom layer of the transmitter PCB by using the synthesizer with a loop filter and a suitable voltage controlled oscillator. The crystal oscillator used in the PLL implementation provides a 10 MHz reference frequency, and a phase noise of -143 dBc/Hz which was achieved at a 1 MHz offset from the required carrier.

The Band Pass Filter is a 7-section Chebychev LC filter which again provides a flexible design. Multiple stages of highly linear amplifiers are implemented to provide power output of anywhere from -10 dBm/SC to +10 dBm/SC.

The transmitter RF PCB is connected to the digital sections as shown in Fig. 13.

The transmitted output spectrum is shown in Fig. 14 which achieved a flat amplitude response within 1 dB from 570 MHz to 670 MHz.

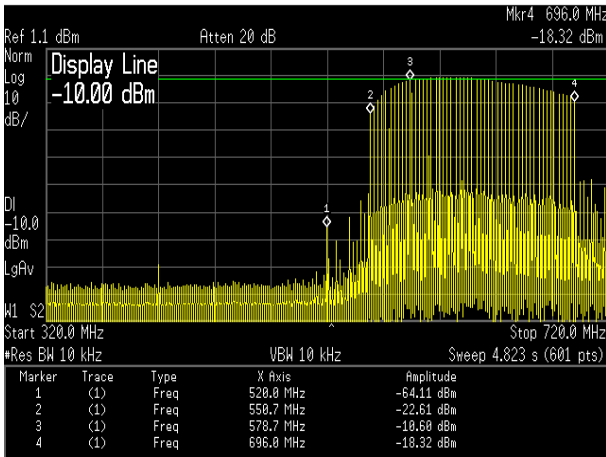

Fig. 14 Transmitter output spectrum.

A response roll-off of 10 dB seen on the lower side of the transmitter spectrum from 550 MHz to 570 MHz, is due to the sharp BPF characteristics required for keeping the LO pass through levels low. A roll-off of 4dB is seen on the high side of the spectrum from 670 MHz to 700 MHz, due to the BPF filter and other device characteristics. Overall, design goals were met or exceeded throughout the 150 MHz wideband transmitter.

150 MHz RECEIVER

The 150 MHz receiver design consists of an RF front end for filtering, amplification and down conversion. The incoming signal is sampled by an ADC at 400 MHz under the control of an FPGA software radio implementation, which then passes the incoming data to a PC for processing via an Ethernet connection. The receiver also includes a control module to communicate with the transmitters on the previously mentioned, separate 915 MHz data channel.

The receiver RF front end consists of a Band Pass Filter (BPF), Low Noise Amplifier (LNA), Down Conversion Mixer, Automatic Gain Control (AGC), and Low Pass Filter as shown in Fig. 15. The RF band pass and the low pass filters are of a custom-made 7-section LC filter configuration. The selection of the LNA is very crucial as the noise figure of the LNA sets the noise figure of the receiver. The LNA chosen has a high gain of 20 dB and a noise figure of 1.6 dB (max).

The wideband mixer that follows the LNA is a high performance active mixer converter implementing direct down-conversion. An RF PLL frequency synthesizer provides the mixer with the required local oscillator signal. The crystal oscillator used in the PLL synthesizer is a 10MHz TCXO with a frequency stability of 2.5 ppm, and the VCO has an output phase noise of 136 dBc/Hz at 1 MHz offset from the carrier. The output of the mixer

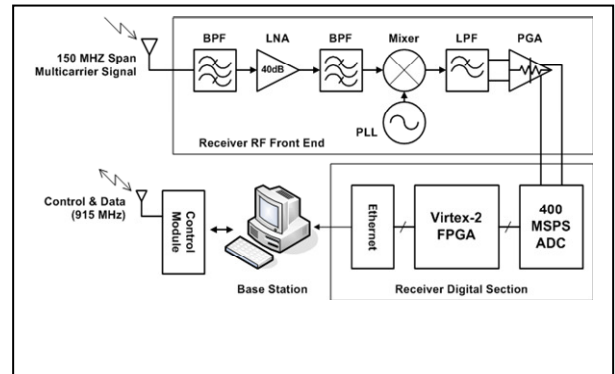

Fig. 15 Receiver block diagram.

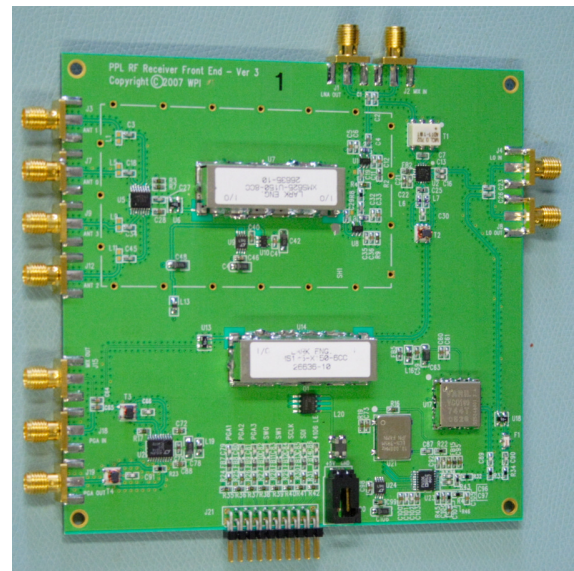

Fig. 16 Receiver RF Front End PCB.

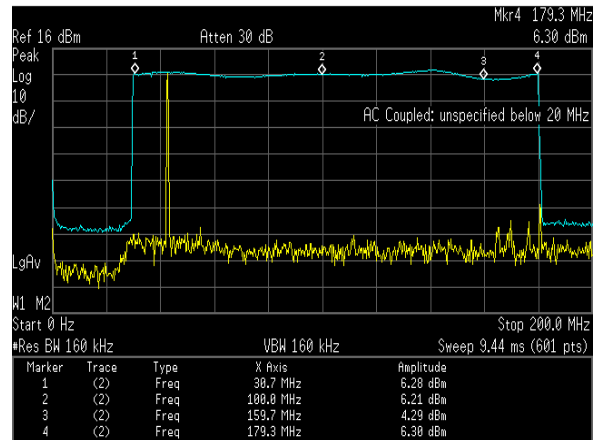

Fig. 17 Receiver frequency response.

drives a digitally controlled variable gain amplifier (VGA/PGA). The PCB implementation of the receiver RF front end is shown in Fig. 16. The receiver frequency response is as shown in Fig. 17, where it can be seen that

Table 1 RF Front End receiver system parameters.

System Parameter	Achieved
System G (dB)	52
System NF (dB)	7
System OIP3 (dBm)	15
Rx. Sensitivity (dBm)	-85
Rx. SFDR (dB)	56

the response of the entire system measured at its output is constant to within +/-1 dB from 30 MHz to 180 MHz. The overall receiver system performance measures are collected in Table 1.

CONCLUSIONS

This paper documents significant progress towards the important goal of precise (sub-meter) three-dimensional personnel tracking in the indoor environment with no pre-installed infrastructure. We have demonstrated better than 1 m accuracy in high multipath environments with a 60 MHz wide signal. At this time we are making further hardware and algorithmic improvements which we expect to drive our accuracy up, and more importantly allow even greater distances and amounts of small-difference multipath to be accommodated. The new RF hardware described here and requisite antenna changes, to be reported in a future paper will enable us to perform our tests in a new 600 MHz band experimental spectral allotment from the FCC with a bandwidth of 150 MHz.

ACKNOWLEDGMENTS

The support of the National Institute of Justice of the Department of Justice is gratefully acknowledged.

REFERENCES

Website: <http://www.ece.wpi.edu/Research/PPL/>

[1] D. Cyganski, J. A. Orr, R. Angilly and B. Woodacre, "Performance Limitations of a Precision Indoor Positioning System Using a Multi-Carrier Approach", Proc. Institute of Navigation, National Technical Meeting 2005, January 24-26, San Diego, CA.

[2] Wireless Personnel Locator Requirements Assessment, Focus Group July 19-21 2004, prepared for WPI by Center for Technology Commercialization, Public Safety Technology Center, August 20, 2004, Worcester, MA.

[3] D. Cyganski, J. A. Orr and W. R. Michalson, "A Multi-Carrier Technique for Precision Geolocation for Indoor/Multipath Environments," Proc. Institute of Navigation GPS/GNSS 2003, September 9-12, Portland, OR.

[4] D. Cyganski, J. A. Orr and W. R. Michalson, "Performance of a Precision Indoor Positioning System Using Multi Carrier Approach," Proc. Institute of Navigation, National Technical Meeting 2004, January 26-28, San Diego, CA.

[5] H. K. Parikh, W. R. Michalson and R. James Duckworth, "Performance Evaluation of the RF Receiver for Precision Positioning System", Proc. Institute of Navigation GPS/GNSS 2004, September 21-24, Long Beach, CA.

[6] R. James Duckworth, H. K. Parikh, W. R. Michalson, "Radio Design and Performance Analysis of Multi Carrier-Ultrawideband (MC-UWB) Positioning System", Proc. Institute of Navigation, National Technical Meeting 2005, January 24-26, San Diego, CA.

[7] D. Cyganski, J.A. Orr, D. Breen, B. Woodacre, "Error Analysis of a Precision Indoor Positioning System," ION AM 2004 Conference, June 7-9, 2004, in Dayton, Ohio.

[8] D. Cyganski, R.J. Duckworth, S. Makarov, W.M. Michalson, J. Orr, V. Amendolare, J. Coyne, H. Daempfling, S. Kulkarni, H. Parikh, B. Woodacre, "WPI Precision Personnel Locator System," Proc. Institute of Navigation, National Technical Meeting 2007, January 22-24, San Diego, CA.

[9] B. Kim, J. Hoon, and H. Choi, "Small wideband PIFA for mobile phones at 1800 MHz," Vehicular Technology Conference, vol. 1, pp. 27-29, May 2004.

[10] C. R. Rowell and R. D. Murch, "A capacitively loaded PIFA for compact mobile telephone handsets," IEEE Trans. Antennas and Propagation, vol. AP-45, no. 5, pp. 837-842, May 1997.

[11] B. Kim, J. Park, and H. Choi, "Tapered type PIFA design for mobile phones at 1800 MHz," Vehicular Technology Conference, vol. 2, pp. 1012-1014, April 2005.

[12] B. D. Rao, K. S. Arun, "Model Based Processing of Signals: A State Space Approach," Proc. IEEE, vol. 80, no. 2, pp. 283-309, Feb. 1992.

[13] J. D. Bard, F. M. Ham, W. L. Jones, "An Algebraic Solution of the Time Difference of Arrival Equations," Proceedings of IEEE Southeastcon '96, April 1996, pp. 313-319.

[14] Committee On Science, U.S. House of Representatives, Meeting the Needs of the Fire Services: H.R. 3992 and H.R. 4548 Hearing Charter, 2318 Rayburn House Office Building, October 2nd, 2002.