

Performance Limits and Field Tests of a Precision Indoor Positioning System using a Multi-Carrier Approach

David Cyganski, John Orr,
Benjamin Woodacre, Ryan Angilly
Worcester Polytechnic Institute

ION – NTM 2005



Project Focus

Precision, ad hoc, indoor/outdoor positioning and associated exchange of data for situational awareness and command/control for

- Firefighters
- Law enforcement officers
- Military
- First-responders
- Corrections officers

System Overview

Personnel Unit

Commander Display

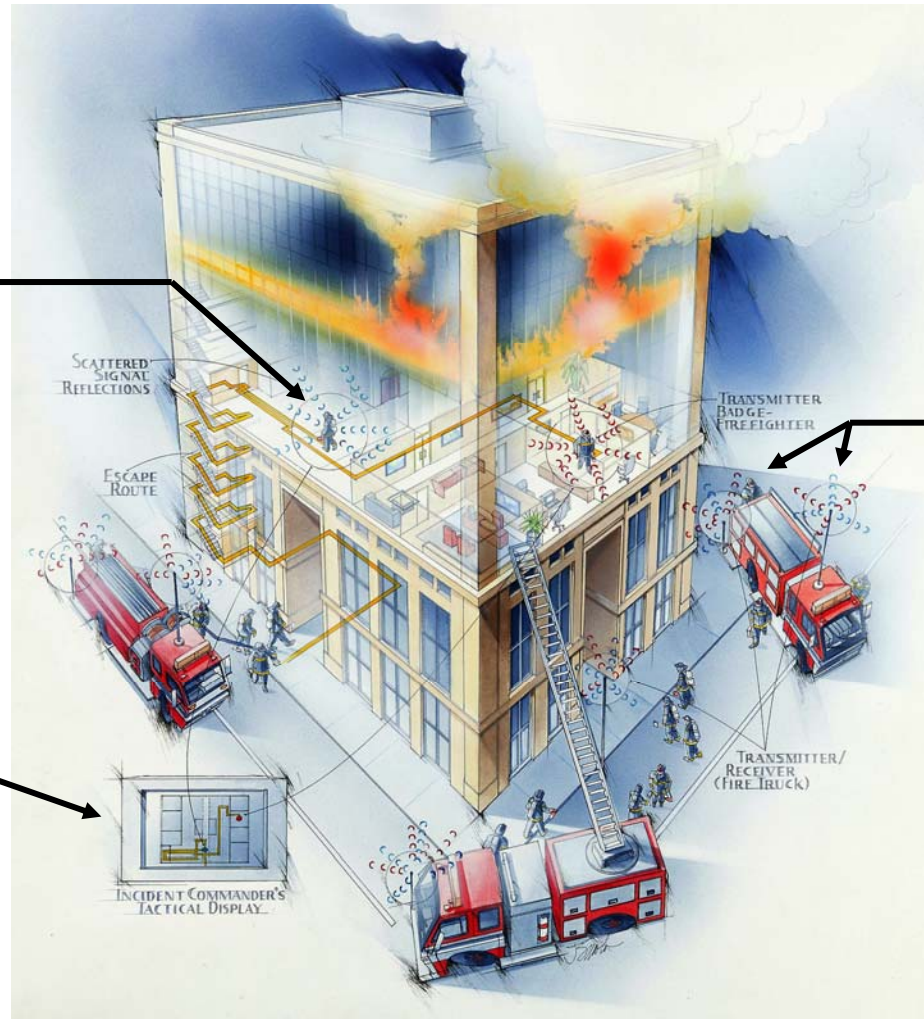

Reference units

Intra-Reference Unit
Communication:
802.11

3-D Escape Routing

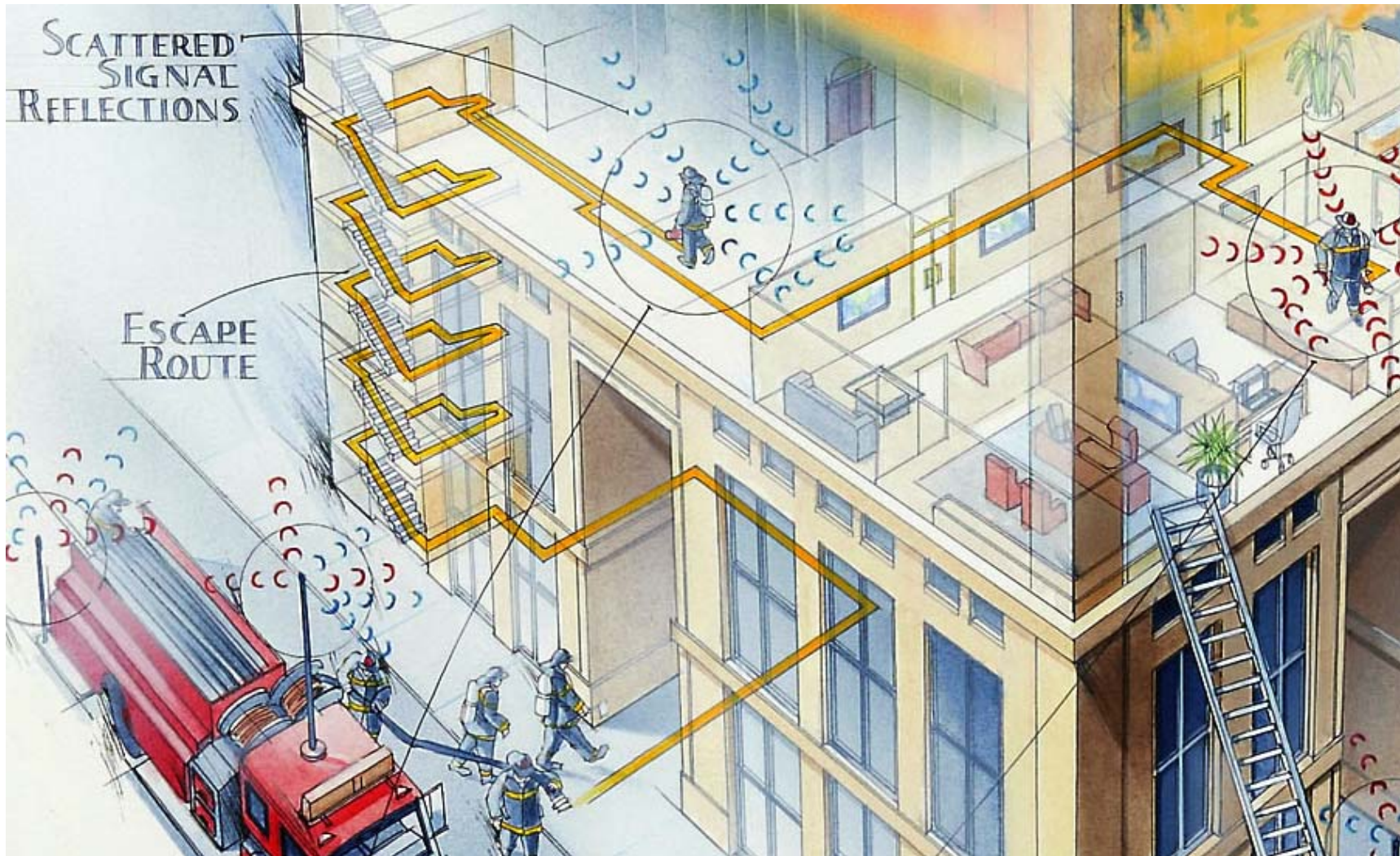

New Results and Context

- *ION-GPS 03*: System Architecture and Principles of Operation, Proof of Concept Demonstration
- *ION-NTM 04*: RF Performance Bounds (no Multipath)
- *ION-AM 04*: Geometric Performance Bounds
- *ION-NTM 05*: Multipath Performance

System Components

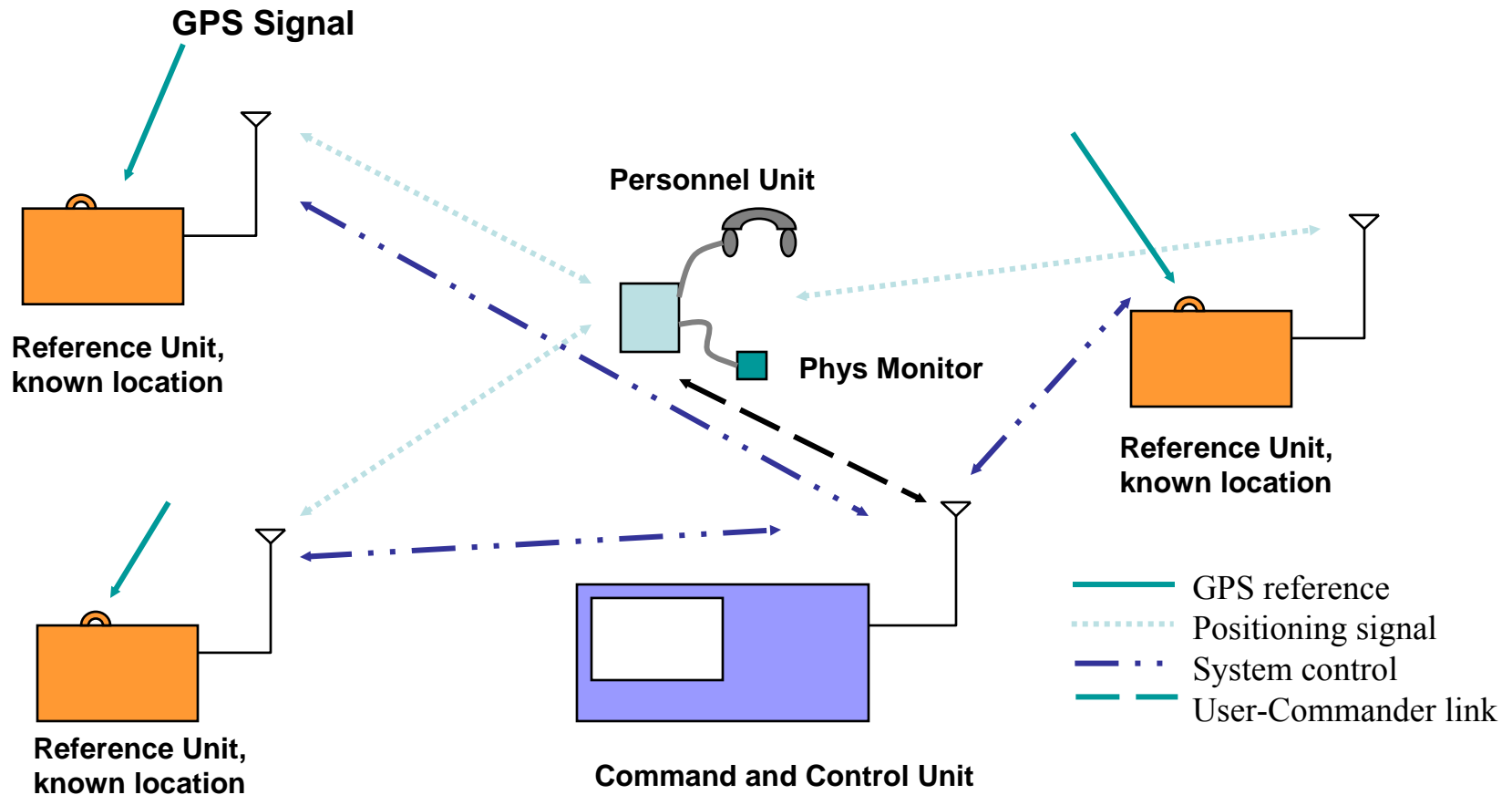

System Requirements

- Number of dimensions: 3
- Accuracy: +/- 1 ft
- Maximum range: 2000 ft
- Max number of simultaneous users: 100
- Fundamental capabilities:
 - 3-D location of each user relative to a chosen reference point
 - Relative locations among users
 - Graphical display at base station
 - Graphical path information on all users
 - Self rescue information to users (audio)
- Enhancements:
 - Physiologic information telemetry
 - Integration with stored databases: geographic and structural

Functional Differences from GPS

- Small operational area ($< \sim 1\text{km}^2$)
- Major focus is *indoors*
- Absolute geo reference may not be needed
- User devices may be active
- Overall system cost must be kept low
- Entire system must be self-initializing, self-monitoring

Technical Challenges

- Multipath
 - The indoor radio environment is much more problematic than outdoor
 - Signal reflections pose a fundamental issue with respect to precision of location.
- Portability and quick set-up
 - Response vehicles must be ready to go with the geolocation system immediately on arrival.
 - Automated reference initialization (site self-calibration).
- Size, cost, power
 - Personnel devices must be small, very low cost and operate without interruption for widespread deployment

Basic Concept

- Sharply defined energy pulses are unnecessary for precise location
 - Avoids problems of wide and flat bandwidth antenna, receiver, and transmitter design
- Multiple continuous carriers that sample frequency space can be utilized
 - Spectrally friendly, near 0 bandwidth components
- Superresolution techniques can trade SNR for increased precision at fixed bandwidth
 - Also provides means for multipath resolution

The OFDM Concept

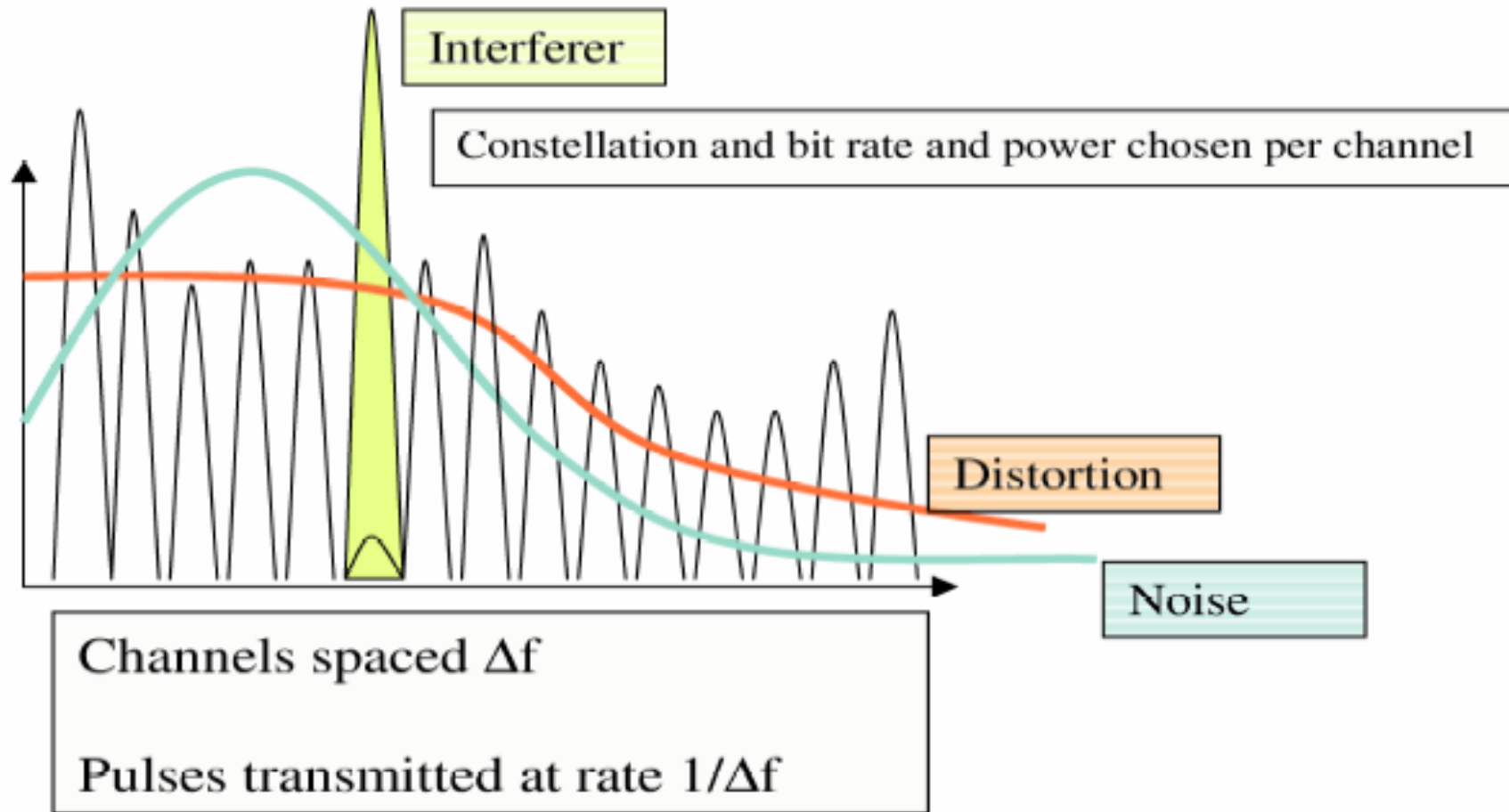

Transmitted Signal

$$s(t) = \sum_{m=0}^{M-1} A e^{j[2\pi(f_0 + m\Delta f)t + \phi_m]}$$

M carriers

Carrier spacing = Δf

Each carrier has arbitrary phase ϕ_m

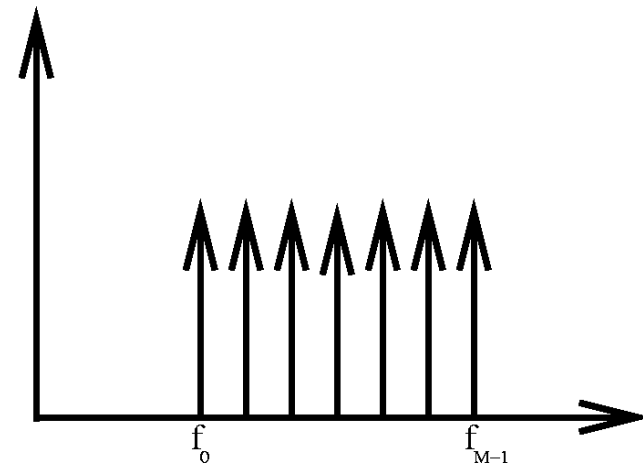

Example Result for 1 Path

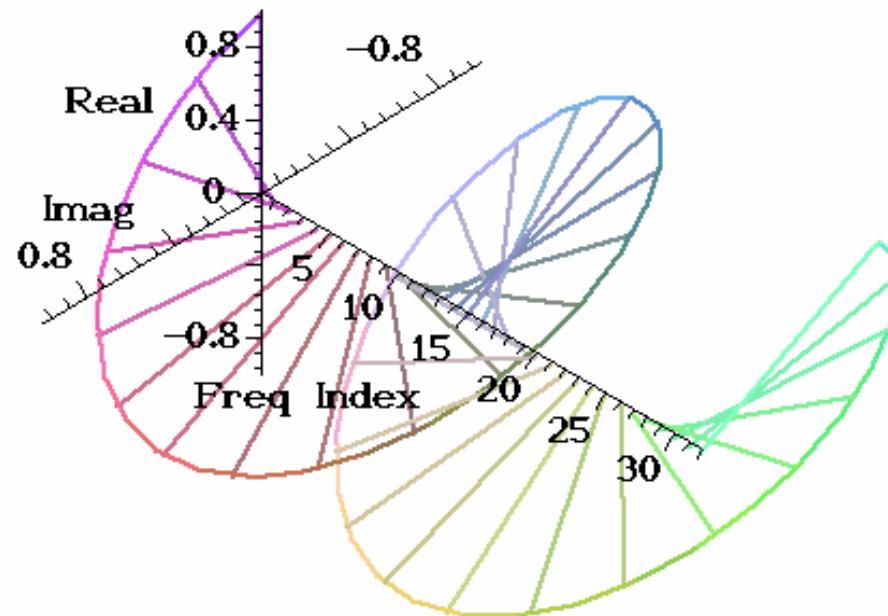

“Freq Index” corresponds to carrier frequencies in the transmitted signal “comb.”

As path length changes...

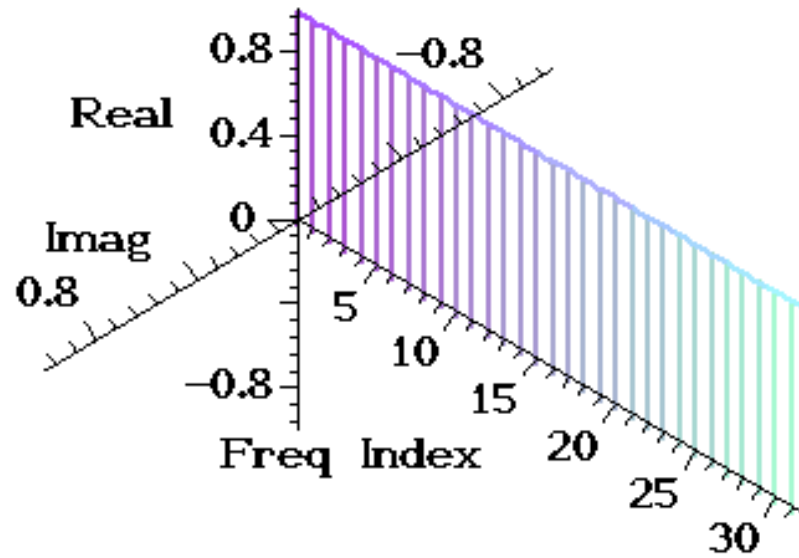

Functional Diagram

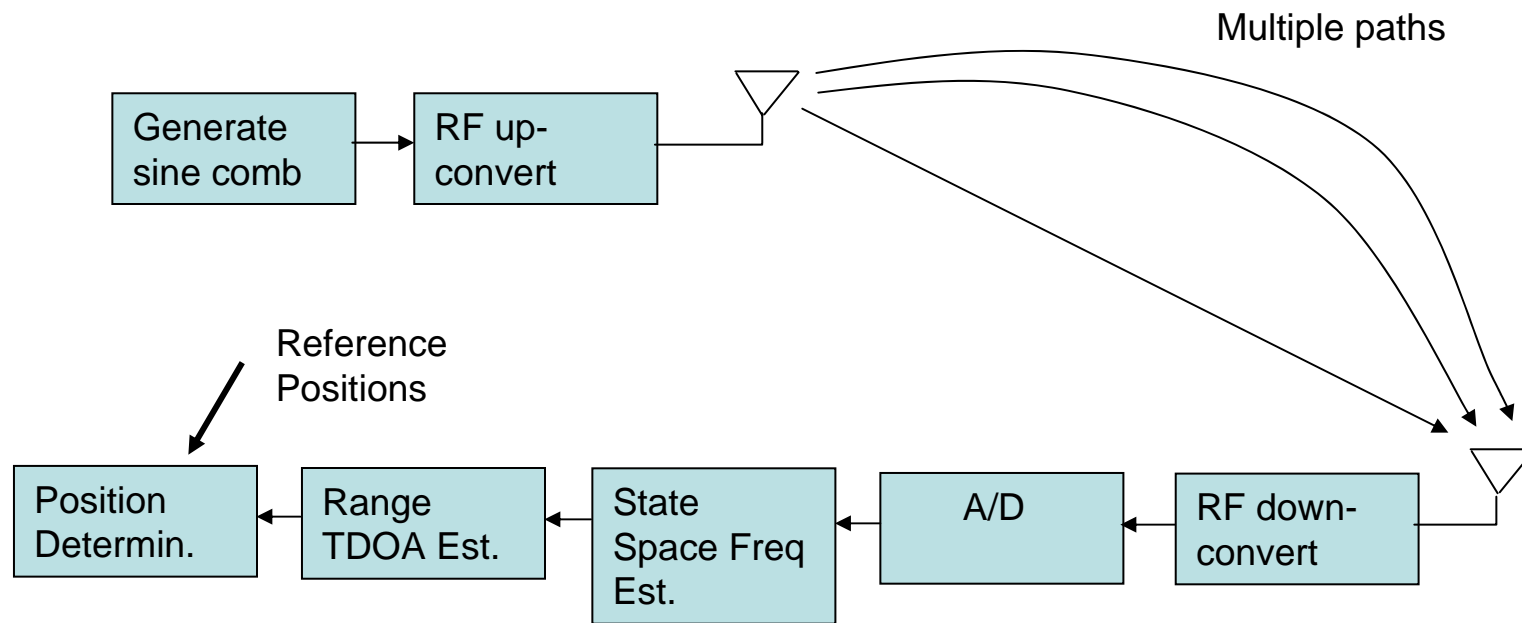

Sinusoidal Frequency Estimation

- Estimation of the frequencies of sinusoids in noise (not necessarily harmonically related) is an old/fertile field
- We use the state space approach:
 - Exact solution (without noise) for P frequencies given $M > 2P$ Fourier samples (comb frequencies)
 - Direct solution, good noise performance
 - Model-based (P must be estimated a priori)

Ranges from Frequencies

- Given the frequencies, TDOAs of all paths immediately follow
- Can reject multipath TDOAs based on inconsistency with a single source (computation-intensive)
- Given time synchronization with transmitter, TDOA becomes TOA and direct paths can be identified directly
- Or, make the system unambiguous range cell larger than the maximum physical operations area, and order solutions to identify shortest path

System Prototype Development

➤ Two RF systems:

- Narrowband (5 MHz) system at 2.4 GHz (completed)
 - Tone modulation of existing off-the-shelf radios
 - Rapid prototype
- Wideband (50 MHz) system at 400 MHz
 - Actual build-out of the OFDM transmitter and receiver

Performance Validation

- Detailed system analysis
- Simulations
 - Standard transmit signal synthesis
 - Standard range determination algorithm
 - No RF
 - Numerical signal delay and noise addition
- Cable tests
 - No RF
- RF tests

Narrowband Range Tests

4 MHz BW,
2.4 GHz carrier



Ranging Performance, Outdoors

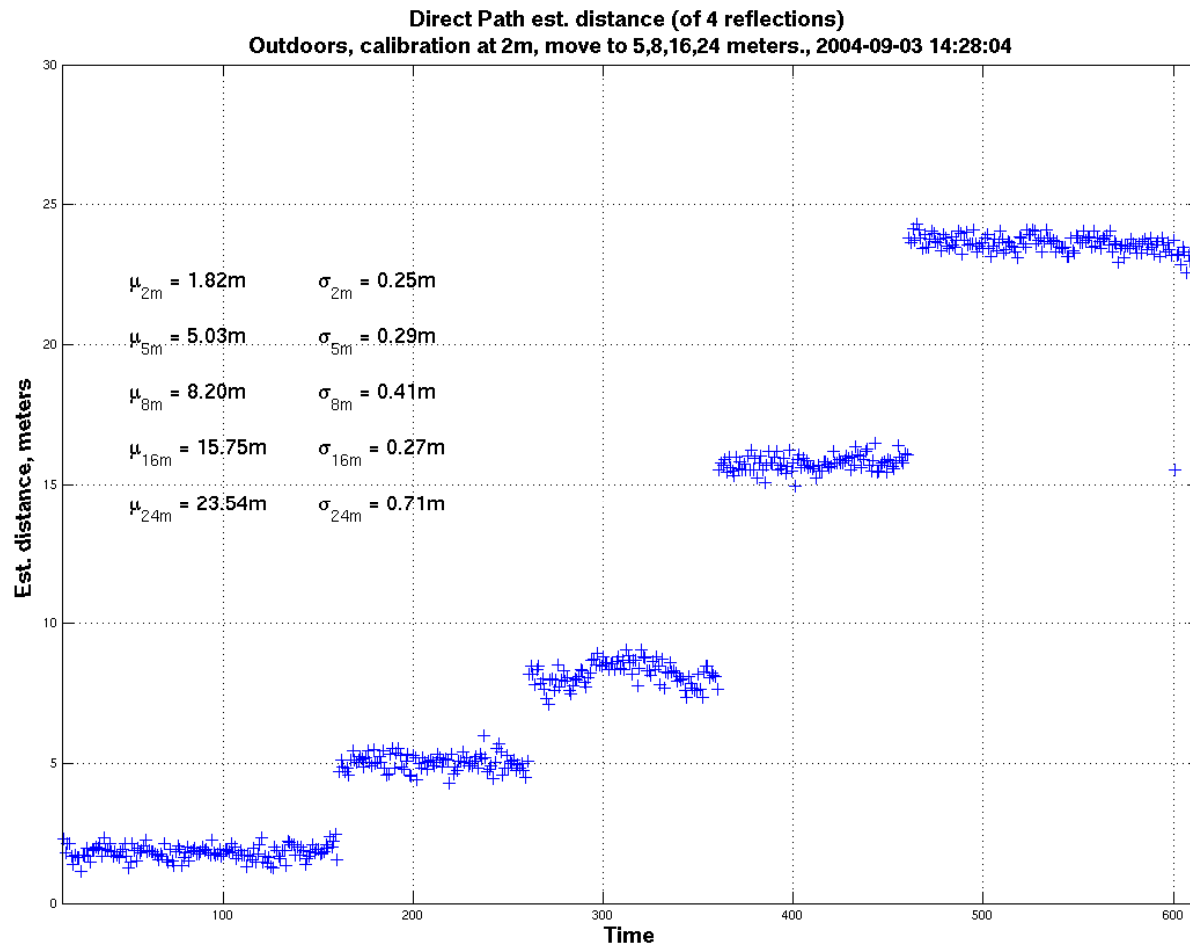

Ranging Performance, Indoors

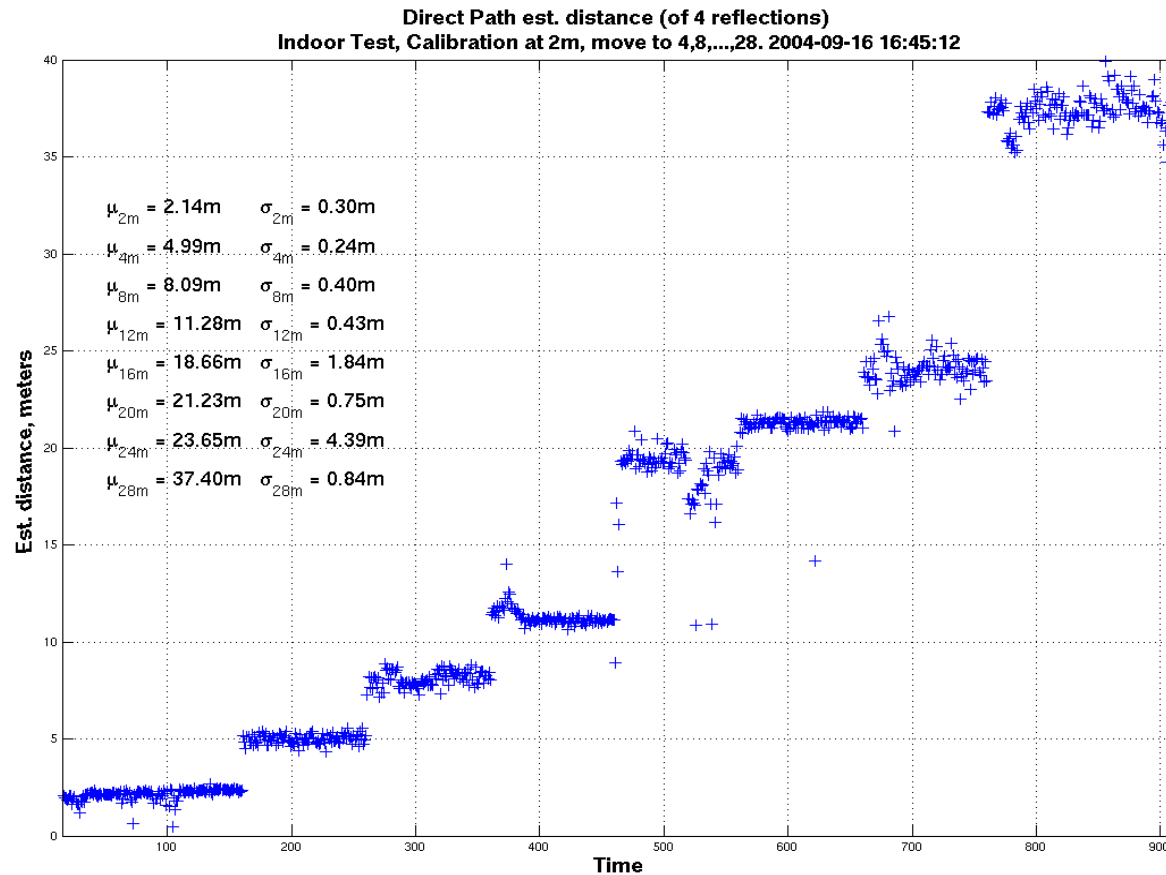

Ranging Performance, Synthetic Data

Direct path estimate given a 0.50 amplitude added reflection
4MHz Bandwidth, 10-70dB SNR, 500 Monte Carlo Tests

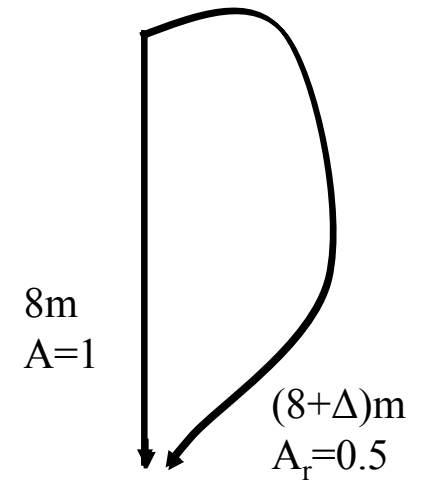
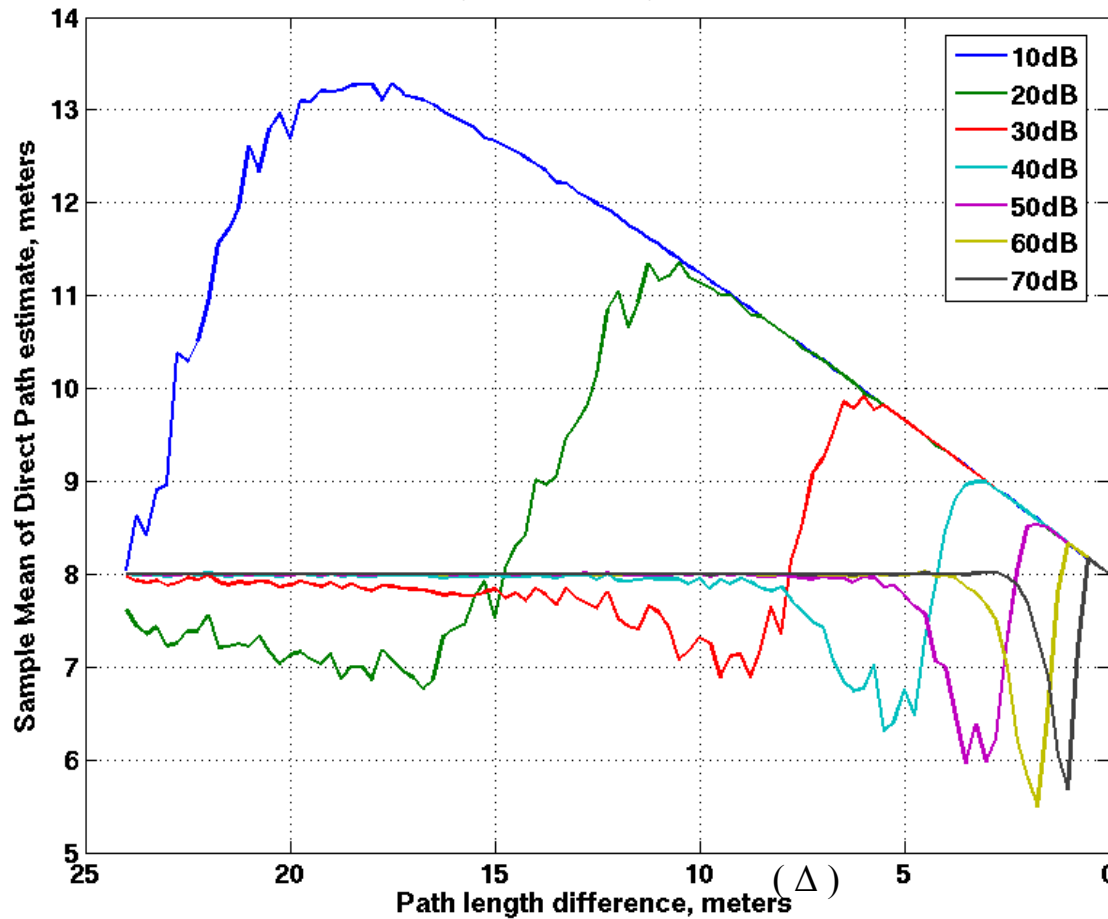

Effect of Reflected Path Amplitude

Direct path estimate given a 1.00 amplitude reflection, 4MHz Bandwidth, 500 Monte Carlo Tests

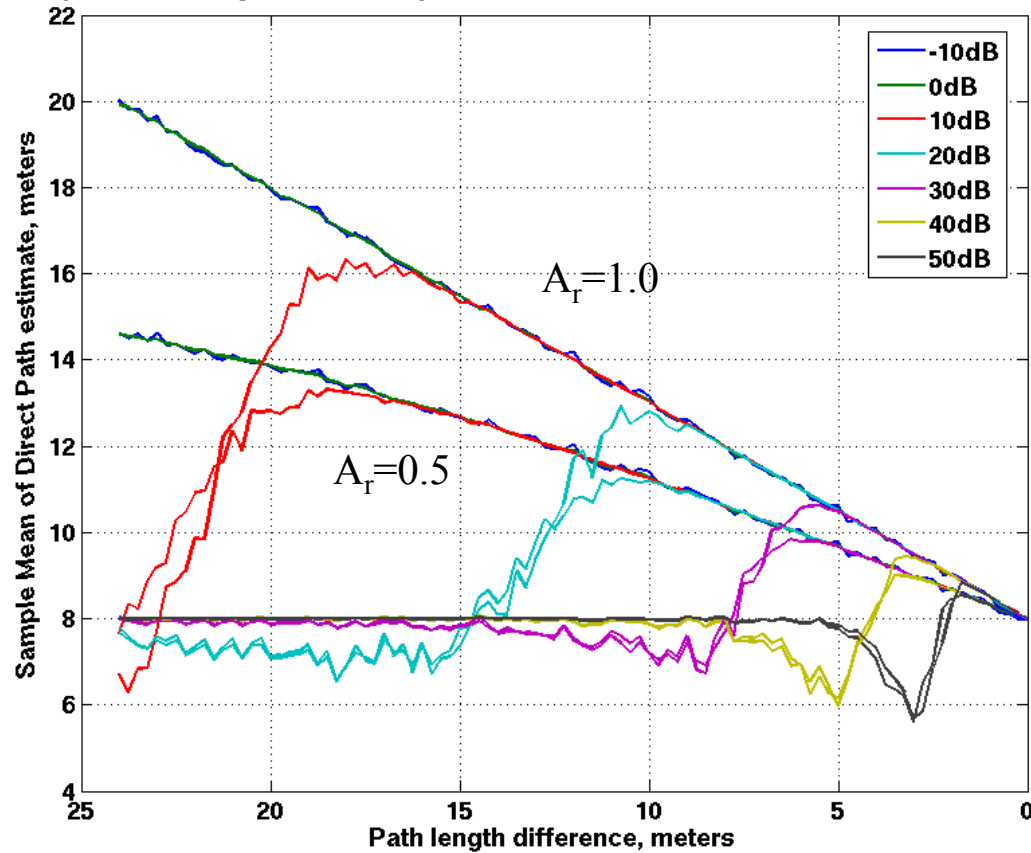

Minimum Resolvable Path Length Difference

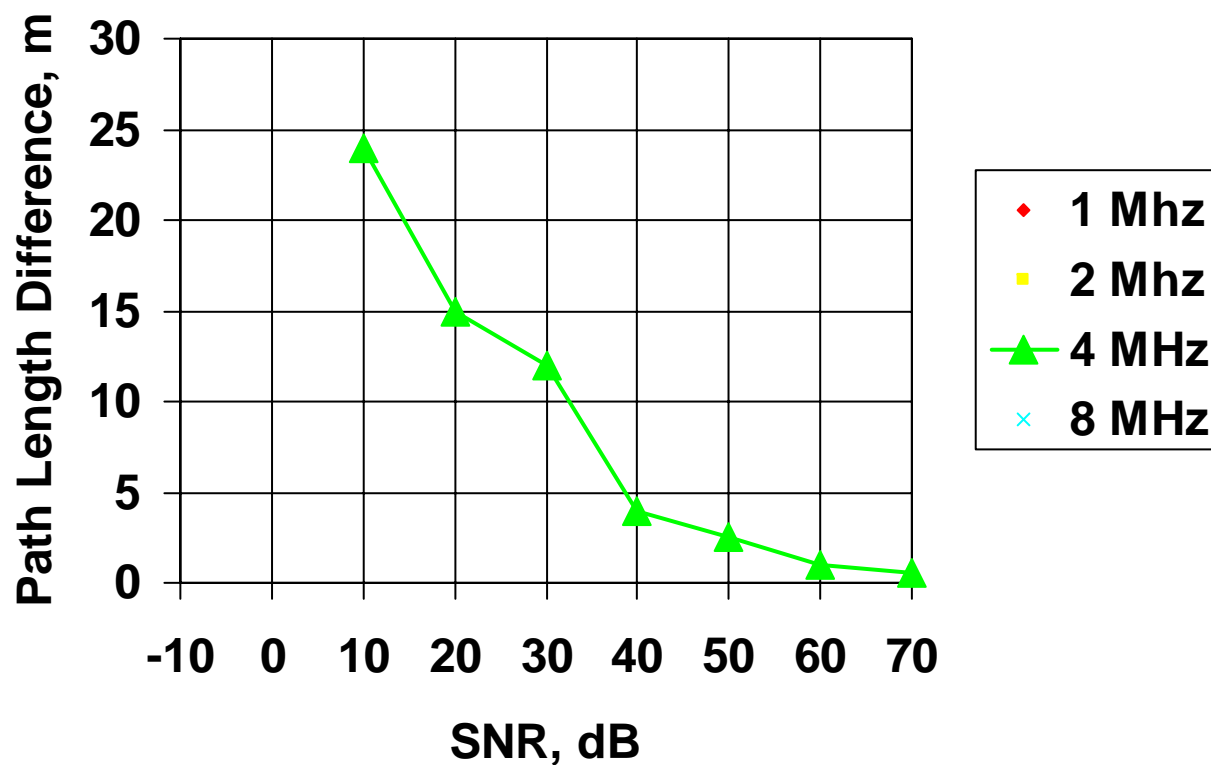

Cable Data

➤ Need data

Next: Wideband RF using Custom Hardware

RF Front End board

Analog to Digital board

Digital Controller board

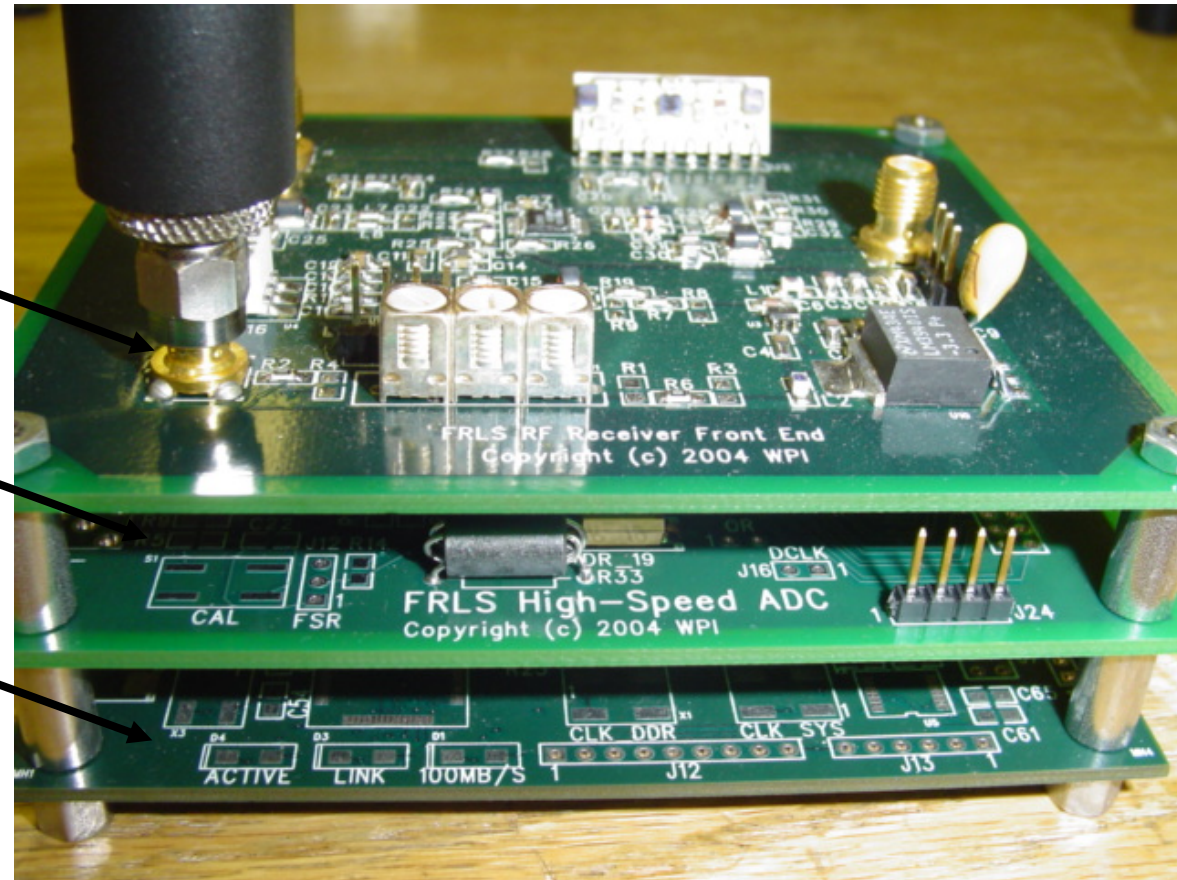

Conclusions

- This analysis provides encouraging results on system performance
- Continuing work will tighten the performance bounds and remove the simplifying assumptions
- Implementation of an RF proof-of-concept system is underway