

GAIT ANALYSIS OF RACEWALKING

Project Number BJS WA08

A Major Qualifying Project Report

Submitted to the Faculty

Of the

WORCESTER POLYTECHNIC INSTITUTE

In partial fulfillment of the degree requirements

Advisor: Professor Brian J. Sivilonis

Stephanie Youkana

Sara Gouveia

Date: April 29, 2008

Table of Contents

Abstract.....	8
Background Information	9
The History of Racewalking.....	9
Gait Analysis.....	10
Force Plates.....	12
Design Objectives.....	13
Expected Outcomes	14
Design Constraints	15
Materials and Methods.....	15
Design Specifications	16
Stress Analysis of Force Plate and Posts Design	22
Analysis of Existing Force Plate	27
Ramp and Platform Design	27
Choosing the Final Force Plate Design.....	30
Mathematical Model of Hip.....	36

Experimental Design Procedure	40
Experimental Design Specifications	40
Experimental Design Alternatives.....	41
Choosing the Final Experimental Design	43
Methods for Measuring Body Angles	43
LabVIEW	44
LabVIEW Overview.....	44
Our Virtual Instrument.....	45
Force Plate Connections	47
Methods for Determining Acceleration	47
Camera	47
Accelerometers	48
BIOPAC	49
BIOPAC Overview.....	49
BIOPAC Accelerometers.....	49
Accelerometer Setup	49
Accelerometer Calibration	50

Accelerometer Problems	52
Calibration of Force Plate	53
Excel File Used in Organizing and Calculating Participant Data.....	55
Data Evaluation Methods	56
Results.....	60
Conclusions	63
Appendix A.....	65
Appendix B	68
Appendix C	71
References	93
Acknowledgments.....	96

Table of Figures

Figure 1: Dimensions	18
Figure 2: Set up of FORCE plate ¹²	20
Figure 3: Wheatstone Bridge Configuration	22
Figure 4: Solidworks model of force plate dimensions.....	23
Figure 5: Free body diagram	24
Figure 6: Free body diagram of post	26
Figure 7: Picture of existing forceplate	27
Figure 8: Ramp and Platform Structure	30
Figure 9: Black Box Diagram	35
Figure 10: Free Body Diagram.....	37
Figure 11: Equations used for mathematical model.....	39
Figure 12: labview vi	46
Figure 13: calibration curve	55
Figure 14: GRF Walking curve	57
Figure 15: GRF Racewalking curve	58

Figure 16: Heel off phase of walking	59
Figure 17: Heel off phase of racewalking.....	59
Figure 18: Average muscle forces	60
Figure 19: average joint forces	61
Figure 20: average Muscle force of all participants.....	62
Figure 21: average joint forces of all participants	62
Figure 22: calibration raw data	68
Figure 23: Calibration trial 1 data	69
Figure 24: calibration trial 2 data.....	69
Figure 25: calibration trial 3 data.....	70

Table of Tables

Table 1: Ramp and Platform Dimensions.....	29
Table 2: Pairwise Comparison Chart	32
Table 3: Pairwise Comparison Chart	34

Abstract

This project determined the forces on the hip joint and hip muscle (hip abductor) during walking and racewalking. The calculated forces were then used to determine which activity, walking or racewalking, exerted more force on the hip. The experimental group first walked using their normal gait and then, after coaching, racewalked. The acceleration of the leg was measured using BIOPAC Accelerometers and the ground reaction force was measured using a force plate and a LabVIEW virtual instrument. The angles of the leg during gait were measured using video of each subject. It was found that the forces on the hip during racewalking were higher than those during regular walking.

Background Information

The History of Racewalking

The first true evidence of bipedal walking was found in 1974 by Mary Leakey in Laetoli, Tanzania. Known as "The Laetoli Footprints" this fossil comprised of footprints from at least two *Australopithecus afarensis* from about 3.6 million years ago. These footprints show that not only were human ancestors walking at that time but also that the gait was heel-strike, much like the gait of humans today.^{1,2,3}

While running became the fastest way to travel many people continued to walk, but with a purpose. Competitive walking began at least four hundred years ago as English noblemen wagered over whose footman was faster.^{4,5} The rules were fairly simple: The competitors were to walk using a "fair heel and toe" technique and were permitted to trot to ward off cramps.^{iv} In the first half of the 19th Century, racewalking had found its way across the Atlantic and, by the late 1870s, had become the second largest betting sport in the United States, second only to horse racing.^{4,6}

The period 1860 to 1903 was called the Pedestrian Age as walking was the leading sport in Europe and America.^{3,6} In 1861 Edward Payson Weston, "the father of modern pedestrianism", had his first major walk. Weston walked from Boston to the President Lincoln's inauguration in Washington DC.^{3,4} In 1874 Weston walked five

hundred miles in six consecutive days. Later that year Daniel O'Leary broke his record and became "Champion Pedestrian of the World."⁷

Not until the 1906 Athens Olympics did walking hit the world scene as a powerhouse sport. The 1500m Walk Olympic record was set by George Bonhag of the United States at 7:12:^{6,8}, and the 3000m Walk was won by Gyorgy Sztantics of Hungary at 15:13.2 at these games.⁹ At the 1908 London Olympics the 3500m Walk, 10 mile Walk, 20K and 50K racewalks were added.^{3,4} In 2000 Poland's Robert Korzeniowski swept the men's 20K and men's 50K walks in the Sydney Olympic Games.⁶ There was much controversy as competitors were disqualified in the last mile before the finish, some not notified of disqualification until after finishing.^{vi} This led to many studies into the rules and biomechanics of racewalking, both of which are still being studied today.

Although racewalking is a popular form of walking, many people still prefer to walk at their own pace for health, fitness, and relaxation. Not until 1968 was there a group, the Internationaler Volkssportverband which promoted this non-competitive walking.^{3,6,10} In the 1990s walking was the most popular form of exercise in the United States, with sixty-five million regular walkers. Walking beat all other forms of sport and exercise by over one hundred percent.⁶

Gait Analysis

The history of gait analysis dates back to Aristotle and his theories on the movement of humans and animals.¹¹ He stated:

If a man were to walk on the ground alongside a wall with a reed dipped in ink attached to his head the line traced by the reed would not be straight but zig-zag, because it goes lower when he bends and higher when he stands upright and raises himself.¹²

Aristotle's theories were never proven however as no experiments were conducted.

Giovanni Alfonso Borelli (1608–1679) performed the first experiment in gait analysis.¹¹ He placed two poles an unspecified distance apart and tried to walk towards them while keeping one pole in front of the other. He found that the near pole always appeared to move to the left and right with respect to the far pole. From this experiment he concluded that there must be mediolateral movement of the head during walking. Borelli also studied the mechanics of muscles and was the first to conclude that the forces within the tendons and muscles are considerably greater than externally applied loads.¹¹

Gaston Carlet (1849–1892) also had a major contribution to gait analysis. Carlet developed a shoe with three pressure transducers built into the sole and recorded the forces exerted by the foot on the floor. He was the first to record the double bump of the ground reaction which we also saw in our project.¹¹

Otto Fischer (1861–1917) and Wilhelm Braune (1831–1892) used continuous exposures from three stationary cameras with a subject walking in the dark with Geissler tubes strapped to his body to determine differences in gait.¹¹ The subject would

walk several times with his normal gait and several times with an army regulation knapsack, three full cartridge pouches and an 88 rifle in the 'shoulder arms' position. Measurements of point coordinates and joint coordinates were taken from the pictures from the camera and the results were plotted by hand. Fischer also calculated the trajectory of the center of mass of each body segment and the whole body. Using a full inverse dynamics approach he also calculated the joint moments for the lower limb joints during the swing phase of gait.¹¹

Major work on gait analysis has been driven by the rehabilitation of war veterans. The first major work with force plates was in reaction to WWI while the first major work using prostheses was in reaction to WWII.¹¹

Force Plates

Braune and Fischer's experiments remained the definitive work on kinematics for several decades, but the development of force plates to enable kinetic measurements continued. Marey and Carlet had developed a pneumatic system to measure in-shoe pressures.¹¹ Demeny and Marey used similar technology to develop a pneumatic force plate that they used in conjunction with a chronophotograph to investigate the energetics of gait.¹¹ Demeny's force plate only measured the vertical component and it was clear that in order to fully understand walking knowledge of all three components of the ground reaction force was required.

Jules Amar (1879–1935) was the first to develop a three-component force plate which consisted of a mechanism that compressed rubber bulbs and transmitted a signal similar to Demenr's approach.¹¹ Amar's work is notable because he was a rehabilitation specialist looking to measure rehabilitation of those injured during WWI.¹¹

In 1930 Wallace Fenn produced a purely mechanical force plate to measure the horizontal component only and Elftman later made a full three-component mechanical force plate in 1938.¹¹ In the late forties, Cunningham and Brown developed a full six-component force plate using strain gauges.¹¹

The first commercially available force plates specifically designed for Biomechanics were piezo-electric plates developed by Kistler in 1969.¹¹ Commercial strain gauge platforms became available in the early 1970s.¹¹

Design Objectives

Through research and experimentation we determined which method, normal walking or racewalking, places more stress on the muscles and joints of the hip. In 1995 a rule change was added to the sport which required racewalkers to keep a straight leg from the point of landing until they were vertical¹³. By determining whether these new rules of racewalking create a greater reaction force when the walker lands, we determined if there are greater forces on the reacting muscles and joint.

The use of a force plate aided in the measurement of the force which results

when one walks. A force plate was used to measure the vertical reaction force and from the readings we mathematically calculate the forces applied to the muscles and joints of the hip and knee when one walks in a normal manner at a normal speed or when one racewalks. We used a model that illustrates the forces in the hip when a person is walking. Acceleration was taken into account using accelerometers. When a measurement was taken using the force plate, the output was the resulting force of the walking motion of this person. We used this number to calculate the muscle forces on the knee.

Once our results were gathered completely we made recommendations based on whether or not racewalking actually places fewer or more stresses on the joints.

Expected Outcomes

We measured the ground reaction forces and calculated the resultant forces in the muscles and joints of the hip when a person walks normally and when the same person walks using the new rules of racewalking. It was expected that we would see greater forces in the muscles in the racewalkers rather than the regular walkers.

Racewalking requires the person to straighten their knee and more force is thus applied to the joints. If the leg is bent at the knee it is most likely that one would see some forces being placed on the muscles in addition to the joints.

Design Constraints

In the designing of a force plate we had to be aware of a several constraints. First, the force plate had to be somewhat portable. It could not be too heavy as to not be moved, but it also could not be too light because it could not deform to any large degree. We also had to make sure that we designed and tested a force plate within a three term period.

Materials and Methods

The most crucial part of this project was the design and building of a force plate. We proceeded through the necessary steps to ensure that we chose the best possible design for the force plate we used. We developed a list of design specifications. The list that follows is a list of things we needed our force plate to do.

Performance Specifications

The following are the specifications for our design. Our design must:

1. Be lightweight and small enough to be considered portable.
2. Support the entire force of a person when walking across the plate
3. Measure the resulting forces from walking.
4. Give us a reading that can be used for calculating the required information
5. Not interfere with normal human gait.

6. Be simple and easy to use.
7. Be reusable and repeatable so that multiple tests can be conducted with the same machine.

While the above list illustrates what we wanted our design to do, the following list shows how we wanted those things to be carried out.

Design Specifications

Our design should:

1. Be made of a metal that will sustain the body weight and resulting forces of our test subjects. This will most likely be 1080 carbon steel.
2. Be compatible with a computer program created in LabVIEW and use this program to provide a meaningful output
3. Be placed in a platform so that it does not interfere with walking patterns
4. Connect to a computer program, LabVIEW, so it is simple to use and understand
5. Not be made of disposable material or function in a manner that only allows it to be used once. It must be able to be calibrated each time a reading is taken so that it can be used many times.

Design Alternatives

When considering how to design a force plate that was inexpensive, portable and accurate, among other things, we had a few different options. Some different

design alternatives were generated, and the final design choice was the design that seemed to be the best alternative.

Our first option was to use the design of a previously existing force plate and simply rebuild it. The force plate that we investigated was first developed in 1979 in an MQP and redesigned in a 1997 MQP by Brian Odegard and Nicholas Bulat.¹⁴ Both of these MQPs used this type of force plate to measure ground reaction forces during human movement. The first measured forces in human running and the latter studied two types of racewalking. We would have to slightly modify this design to use for our purposes because it was used for the same type of experiment that we will be conducting.

The force plate itself is of triangular shape with three strain gages located at each of the vertices of the triangle. Since we needed to measure vertical reaction force on the hip we would place vertical load cells at these three locations. The triangle is isosceles and when measured had the basic dimensions shown below in Figure 1.

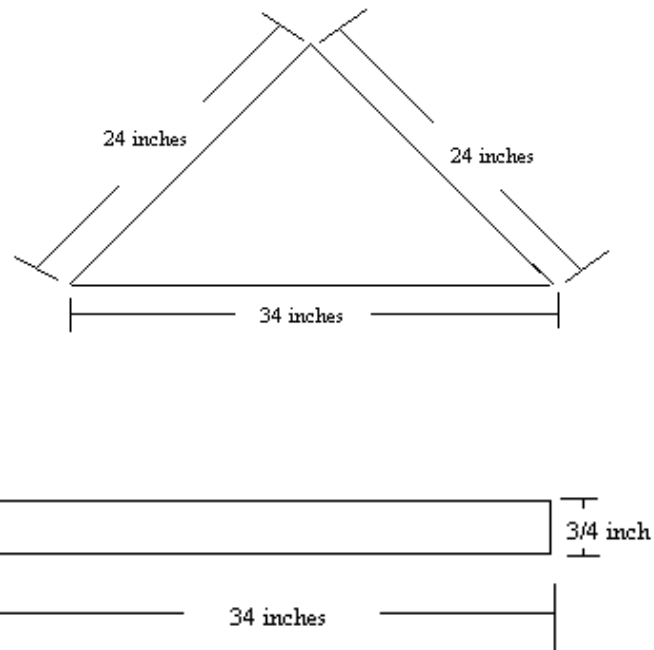

Figure 1: Dimensions

The ground reaction force was measured using the force plate and the muscle and joint reaction forces were calculated through force and moment equations that are presented later in the report.

The maximum load that this force plate can withstand is said to be almost 5000 Newtons.⁷ Since this force plate was originally designed to test running and long jumping in 1979, this value was actually a great deal larger than we really needed it to be.

Using the formula:

$$P_{max} = P_s(g_{max}) + P_p$$

where P_{max} is the maximum estimated force that will be applied to the force plate, P_s is

the maximum estimated force due to the person walking on it, g_{max} is the number of G's on impact, and P_p is the maximum force of the metal sheet which is placed over the strain gages, we determined approximately how much force is placed on the force plate and if the system can handle such a force.

The force plate is said to hold about 1,124 pounds of force, which is 5000 Newtons. After calculating the P_{max} , we determined that the maximum force that would be placed on the force plate from a walker in our experiment would be around 800 pounds, about 3559 Newtons. This was calculated assuming that a person weighing 200 pounds would be walking on the force plate.

Force Plate Design

This force plate would measure the vertical reaction force of a person who walked across it. We wanted it to be portable and lightweight, but also be capable of supporting the weight of an average size person while they are walking. A stress analysis was conducted on the existing force plate dimensions and is presented in the next section. 6061-T6 aluminum was the metal selected for the analysis because previous plates had been built of this. We physically measured the force plate that was already built and simply use those dimensions in our design.

The dimensions that were measured from the existing force plate were presented in Figure 1. The force plate is triangular in shape and is supported laterally by support beams. The entire structure would be mounted to a large wooden board.

The three load cells that we would be using will be made out of 6061-T6

aluminum, just as they were designed in the 1997 MQP report we referenced for our force plate model. From the measurements and the 1997 MQP we would make the load cells about 4.06 cm long and about 19.01 mm in diameter if we were to build this model. The general setup of the plate and the locations of the load cells are seen in Figure 2.

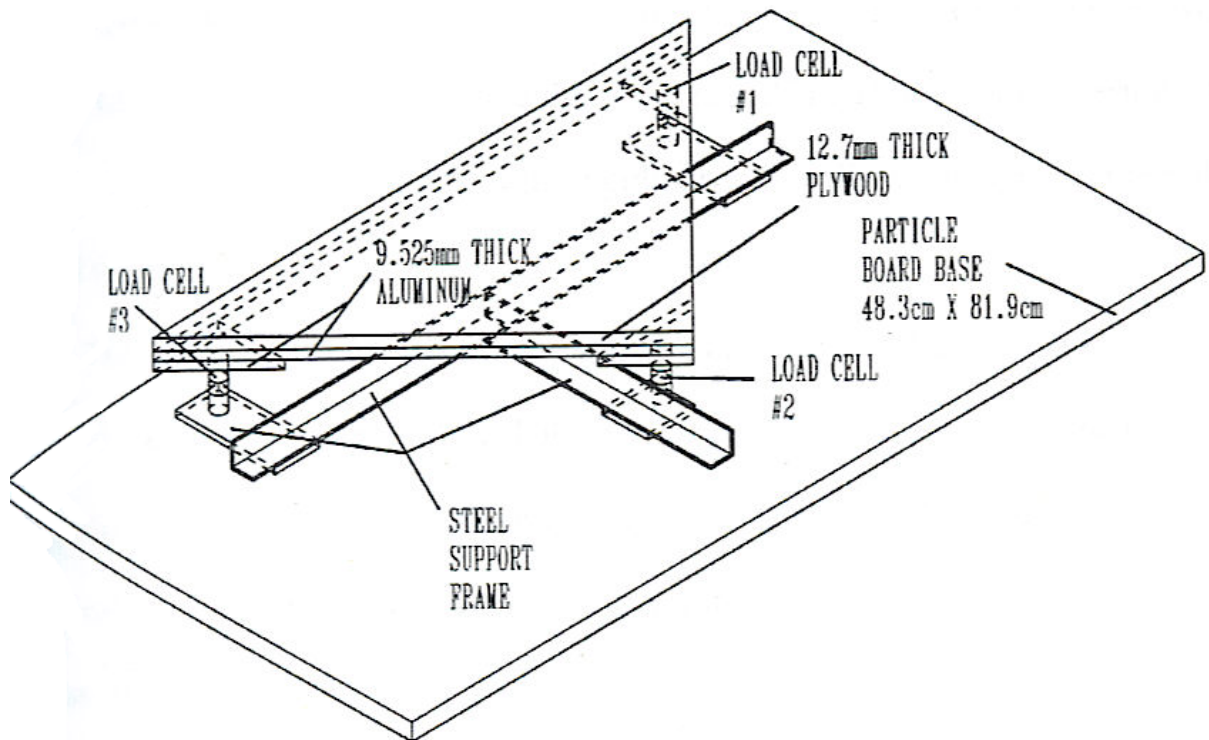

Figure 2: Set up of FORCE plate ¹²

The forces that are placed on each of these three load cells would be determined by strain gages. When the load cells undergo deformation due to an applied stress the strain gages will convert this and emit an electrical signal. This configuration has a 120

Ohm grid resistance. Anytime there is a small change in this resistance an electrical signal is emitted and the data is sent to the virtual instrument we design in LabVIEW. The cells will be hollowed out by drilling a 12.7 mm hole and the outer diameter of the cells will be reduced by 2.54 mm for a certain length in the middle of each cell. The data collected can be used to find the force in the load cells and then plugged into our model equations to find muscle and joint reaction forces.

The forces on the load cells would be determined using strain gauges on the middle section of the cells in which the outer diameter is reduced. As the load cells compress and elongate the strain gauges would determine the force seen on each individual cell. The gauges act as potentiometers that change impedance proportionally with changes in strain. These changes would result in millivolt changes which will be amplified using a VI and LabVIEW and used to calculate the force on the load cell.

Four strain gauges would be attached to each of the load cells. Two of the gauges would be vertically mounted to measure axial stresses while the other two gauges would be mounted horizontally to measure hoop stresses. When a compression force is placed on the cells the vertical gauges compress while the horizontal gauges elongate.

The strain gages need to be placed in a certain manner to measure compressive and tensile stresses. The configuration that they are placed in is the Wheatstone Bridge Configuration, as seen in Figure 3 below.

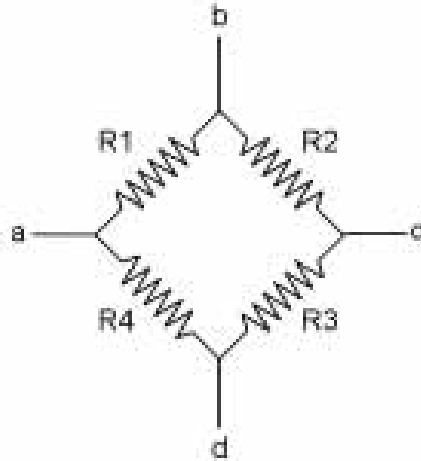

Figure 3: Wheatstone Bridge Configuration¹⁵

One of the keys to the design process is never to reinvent the wheel. We took this saying into consideration when looking at possible designs for force plates. Another option that we had was to use a force plate that was already built and available to us. Professor Hoffman made available a force plate that measures the vertical force only. It was located in the biomaterials lab and needed only a few simple adjustments to use for our needs. This force plate is compatible with LabVIEW, which was also one of our requirements for our design.

Stress Analysis of Force Plate and Posts Design

A stress analysis of the existing force plate design was conducted to determine if it was in fact a viable option.

A few assumptions were made in order to make the problem work. We assumed that all forces act on the center of the plate and there is no moment on the posts. We also assumed that the force is placed at the center of the posts.

The following diagram is a Solidworks model of the force plate that would be built from the pre-existing design. It is made of 6061 aluminum. It has a mass of 20.90 pounds and a surface area of 634.48 cubic inches. The center of mass is located at $x = 15.84$, $y = 0.38$, $z = -4.93$.

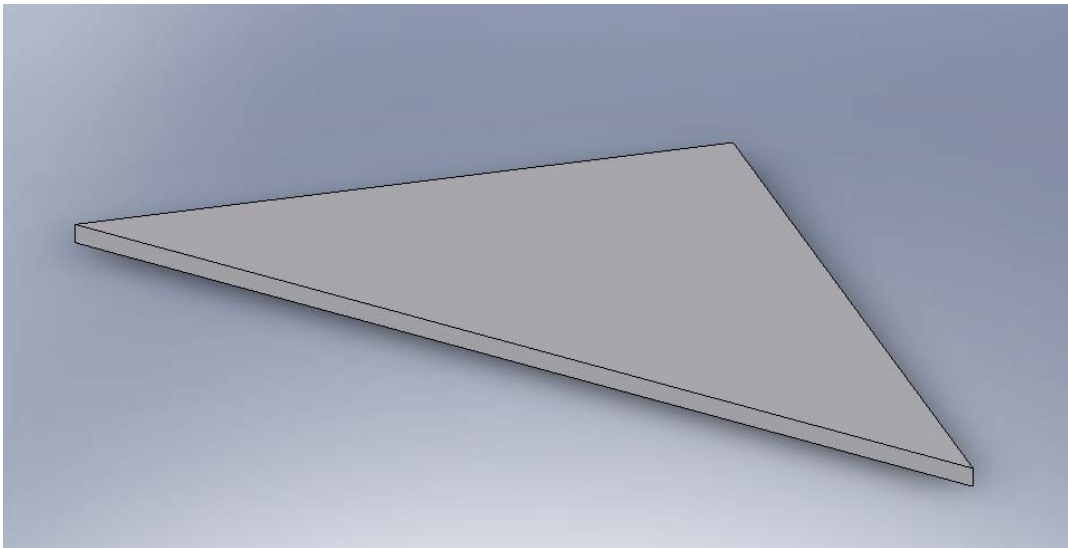

Figure 4: Solidworks model of force plate dimensions

The following is a free body diagram of the force plate and the external forces acting on it.

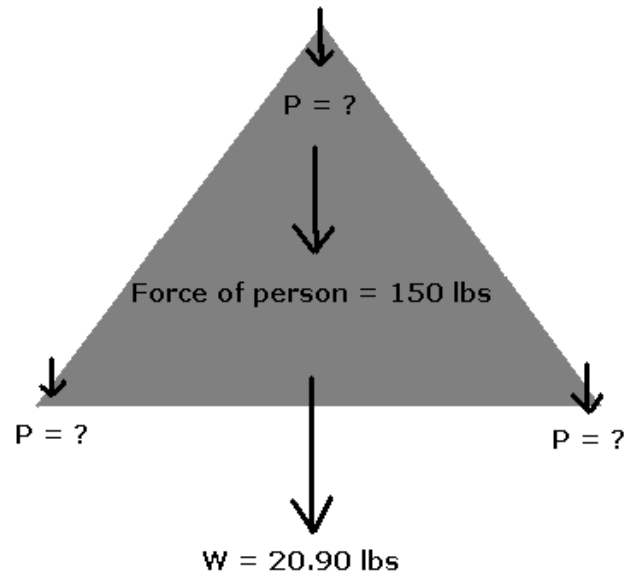

Figure 5: Free body diagram

P represents the force acting on each post, W represents the weight of the aluminum plate, and the force of the person is represented as 150 pounds. The following calculations were made to determine the final force on each post. It was assumed that the force acts on the center of the post at all times and that the weight of the posts is negligible. The results are far below the yield and ultimate stresses for 6061 aluminum.

$$\Sigma F = P - N = 0$$

$$P = \text{force/weight on each post} = 56.97 \text{ lbs}$$

N = normal force = unknown

P = N = 56.97 lbs

Assume: Force on center of post at all times

$$\Sigma F = P + W_p - N = 0$$

P = force/weight on each post = 56.97 lbs

W_p = force/weight of post = 1 lb

N = normal force = unknown

$$P + W_p = N$$

$$(56.97 \text{ lbs}) + (1 \text{ lb}) = 57.97 \text{ lbs} = N$$

Negligible Difference

$$\sigma = P/A$$

σ = stress = unknown

P = force/weight on each post = 56.97 lbs

$$\sigma = (56.97 \text{ lbs})/(A)$$

Yield Stress = 29,500 psi

Ultimate Stress = 39,600 psi

The following is a free body diagram of one of the posts of the force plate.

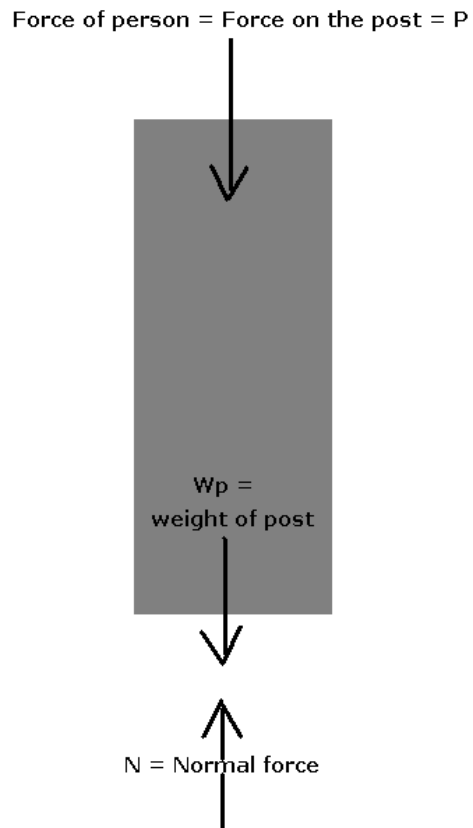

Figure 6: Free body diagram of post

In this calculation we assumed that the weight of the post is negligible and therefore did not take it into account. Therefore, P , the force on each post, would be 56.97 pounds.

Analysis of Existing Force Plate

The existing force plate that we chose to use needed to be tested and analyzed to determine its specifications. We did this by conducting calibration tests on it and manually determining its specifications. The force plate is pictured in figure 7 below.



Figure 7: Picture of existing forceplate

Ramp and Platform Design

Given the height of the force plate there needed to be a way for the racewalker to get to that height without changing their form. To solve this problem a ramp and

platform were built around the force plate. It is important to gradually increase the slope of the ramp so as not to affect the subjects' gaits significantly while having a flat section for the subjects to obtain a normal gait.

In order for a subject to obtain the gait needed for analysis in this study the portion of the ramp directly in front of the force plate needed to be on the same level as the force plate. This section had to be long enough to give a subject sufficient recovery time to acquire a normal gait. Once a subject struck the force plate there needed to be a sufficient amount of platform to decelerate under controlled conditions. If the subject does not believe that he/she can continue their normal gait after he/she passes over the force plate their gait may be altered subconsciously. This could potentially affect the force plate readings and kinematic properties associated with the gait cycle under consideration.

It was determined through the 1997 MQP that the minimum amount of level ramp needed to allow proper gait was the length of two full gait cycles. It was also determined that the platform needed to be at least one gait cycle long after the force plate.

The basic design for the ramp and platform is a 2" x 4" skeleton with a 3/4" plywood walking surface. The width of the ramp and platform is 24" and the overall length, including force plate, is approximately 17' 6". In order to make the ramp and platform mobile and easier to construct it was divided into five sections. Table 1 shows each section and their dimensions and Figure 4 shows a breakdown of the ramp and

platform, including the underlying 2" x 4" skeleton. Section 4 is significant because this is the part of the platform where the force plate was placed. Figure 8 shows a picture of the ramp built.

Section	Level	L x W (feet)
1	Ramp	4 x 2
2	Platform	3 x 2
3	Platform	3 x 2
4	Platform	3.5 x 2
5	Platform	3 x 2

Table 1: Ramp and Platform Dimensions



Figure 8: Ramp and Platform Structure

This ramp construction was more than adequate to support any size walker under any conditions. The 2" x 4" skeleton made the carrying capacity of the ramp extremely high and incorporated a large safety factor. The safety of the subjects was very important during this study and we wanted to ensure that they felt comfortable when walking on the platform.

Choosing the Final Force Plate Design

There are several methods that can be used to choose between design alternatives. After considering all objectives and functions of the project in detail, each force plate was then evaluated. There are several methods to do this, including pairwise comparison charts, weighted objectives, black box diagrams and function means trees. Each one of these exercises can evaluate what the design would have to accomplish, and ultimately aid in choosing the final design by allowing one to prioritize functions based on need and want.

A pairwise comparison chart is used to rank design objectives. The objectives are listed as both the rows and the columns of a chart and they are compared to each other one by one. This tool was very useful because it aided in ranking the design objectives very early in the design process and allowed us to generate weighted objectives. By doing this, it became evident what objectives were more important and

which design had the capability of properly carry out all of these objectives.

The first pairwise comparison chart that we created can be seen below in Table

2. It contains the basic design objects that we wanted our design to encompass.

☐	Accurate	Reliable	Inexpensive	Portable	User Friendly	Reusable	Score
Accurate	X	½	1	1	1	½	4
Reliable	½	X	1	1	1	½	4
Inexpensive	0	0	X	½	½	0	1
Portable	0	0	½	X	½	0	1
User Friendly	0	0	½	½	X	0	1
Reusable	½	½	1	1	1	X	4

Table 2: Pairwise Comparison Chart

Using Table 2 we were able to rank these objectives in order of importance according to what we thought our design should be. We concluded that among these basic objectives, device accuracy, reliability, and reusability were the three most important objectives. The device should also be inexpensive, portable, and user friendly, but should not sacrifice the other three more relevant objectives to do so. This simple pairwise comparison chart was generated to help us better understand the task at hand, and how we should actually approach the problem and decide which of the two design alternatives was our best option.

We created a second pairwise comparison chart to compare the more specific objectives we had for our design which can be found in Table 3.

	Light weight	Support weight	Measure resultant forces	Generate relevant reading	Not interfere with gait	Easy to use	Multiple tests run	Score
Light weight	X	0	0	0	½	½	0	1
Support weight	1	X	½	½	½	1	1/2	4
Measure resultant forces	1	½	X	½	½	1	½	4
Generate relevant reading	1	½	½	X	½	1	½	4
Not interfere with gait	1	½	½	½	X	1	½	4
Easy to use	½	0	0	0	0	X	0	½
Multiple tests run	1	½	½	½	½	1	X	4

Table 3: Pairwise Comparison Chart

Table 3 illustrates the detailed objectives and which ones rank more important than the others. This helped us to conclude that it is equally important for the design we choose to support the entire weight of the person standing on it, to measure the resultant forces of this person when walking, generate a relevant reading that is useful to our study, not interfere with normal human gait, and to allow us to run multiple tests on it. It should next be light weight so it can be somewhat portable and then be easy to use.

To illustrate what we wanted the design to do we created black box functions. These made it easy to visualize what we needed to put into the force plate and what we needed to get out of it. The following diagram, Figure 5, is a black box diagram that illustrates just what the force plate had to do.

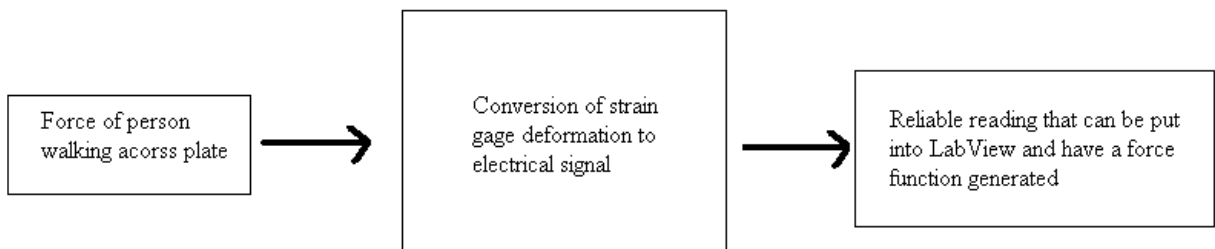

Figure 9: Black Box Diagram

Based on these tools it was determined that the force plate made available by Professor Hoffman was capable of measuring all we needed to measure. This force plate

was hooked up to Labview and through calibrations and preliminary testing an equation was developed to convert the millivolts outputted into force in pounds. This calibration and equation will be explained further on in the report.

Mathematical Model of Hip

Once the ground reaction force was calculated using the information from our LabVIEW program we used the following method to solve for the resulting muscle and joint forces. This method consisted of a two dimensional model.

The hip when walking is represented in a free body diagram in figure 10 below.

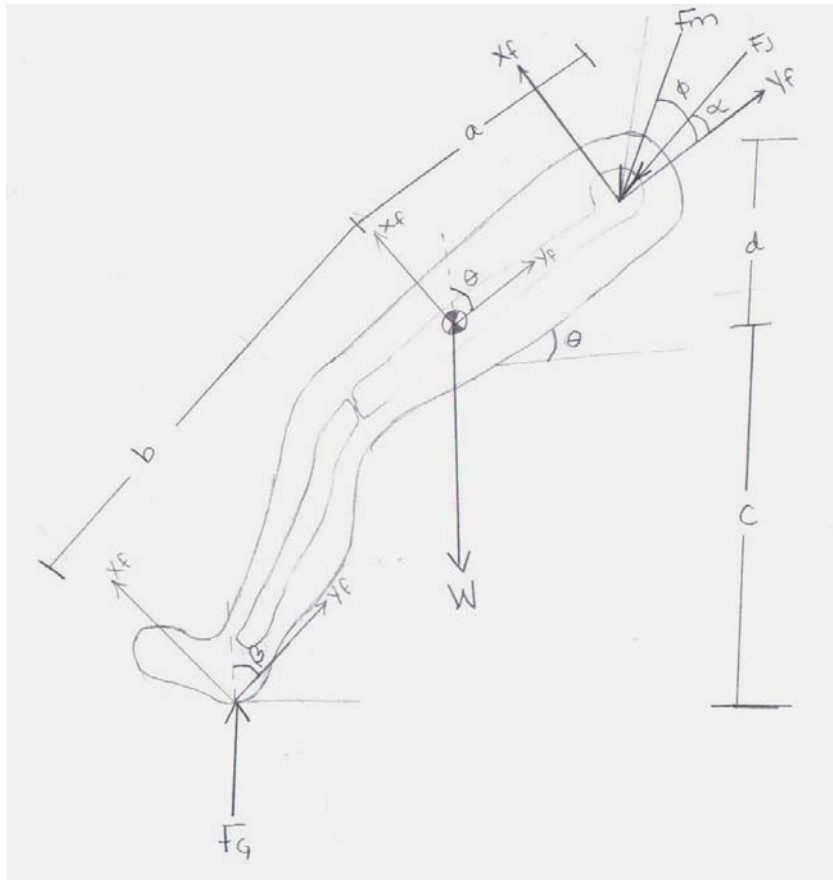

Figure 10: Free Body Diagram

F_m , F_j and α represent the three unknowns we found through calculations, muscle force, joint force and joint angle, respectively. W , F_G , β , θ , ϕ , α represent shank and thigh combined weight, ground reaction force, foot-ground angle, hip angle, muscle angle, and joint angle, respectively. The letters a , b , c , and d represent the defined lengths as seen in the diagram. These were physically measured on each individual participant with the exception of ϕ . This muscle angle was taken from literature to be

48 degrees.¹⁶ The angles are all with respect to the defined coordinate system where Yf lies along the line of the femur, known as the femoral axis.

The two force equations and the moment equation were taken about the center of gravity of the entire leg. The center of gravity and weight of the limb was also calculated for each individual participant using two separate equations for the thigh and the shank. The two equations are as follows:

$$\text{Weight of thigh} = 0.127 * (\text{body weight}) - 14.82$$

$$\text{Weight of shank} = 0.044 * (\text{body weight}) - 1.75$$

$$\text{Center of gravity of thigh} = 39.8\% \text{ length from hip}$$

$$\text{Center of gravity of shank} = 41.3\% \text{ length from knee}^{17}$$

The following equations seen in figure 11 are the sum of the forces in the x direction, y direction, and the sum of the moments about the center of gravity.

$$\begin{aligned} \sum F_x &= -F_m \sin \phi - F_j \sin \alpha + F_g \sin \beta - W \sin \theta = m a \\ \sum F_y &= -F_m \cos \phi - F_j \cos \alpha + F_g \cos \beta - W \cos \theta = m a \\ \sum M_{com} &= (F_g \sin \beta)(b) + (F_g \cos \beta)(c) - (F_m \sin \phi)(a) \\ &\quad - (F_m \cos \phi)(d) - (F_j \sin \alpha)(a) - (F_j \cos \alpha)(d) \\ &= I \alpha \end{aligned}$$

Figure 11: Equations used for mathematical model

These equations were rearranged into the following equations 1 and 2 so the previously mentioned unknowns could be determined:

$$\begin{aligned} F_m &= \frac{(F_g \cos(90 - \beta) \tan(\phi) - \sin(90 - \beta)) + W(\sin(\theta) + \cos(\theta) \tan(\phi)) + m(ax - \tan(\phi) ay) \cos(\alpha)}{\cos(\phi) \cdot (\sin(\alpha) - \cos(\alpha) \tan(\phi))} \\ &\quad + \frac{F_g \cos(90 - \beta) - W \cos(\theta) - m \cdot ay}{\cos(\phi)} \end{aligned}$$

Equation 1

$$F_j = \frac{F_g \sin(90 - \beta) - W \sin(\theta) - m \cdot ax - \tan(\phi)(F_g \cos(90 - \beta) - W \cos(\theta) - m \cdot ay)}{\sin(\alpha) - \cos(\alpha) \tan(\phi)}$$

Equation 2

Experimental Design Procedure

In order to design the best possible experimental procedure we needed to consider several things. The experimental procedure consists of several design specifications that would help us to determine if there are significant differences in the muscle and joint reaction forces in the hip between regular walking and racewalking.

Experimental Design Specifications

Our experimental design should:

1. Allow for multiple sessions for teaching and practicing racewalking
2. Have the same participant be measured for normal walking and for racewalking.
3. Allow for sufficient practice time for each participant.
4. Get a reading for reaction force and acceleration.
5. Have a fairly large number of participants (about ten) so there is a broad range of data.

Experimental Design Alternatives

Based on the developed experimental design specifications there were multiple possibilities for experimental design procedures. There were also two possible risks taken into account, although minimal, that participants could encounter. First, there was the potential for slight discomfort when performing the experiment depending on the individual's gait. The participants would also feel the effects of light exercise. These were very small risks and they varied with the participant.

Each participant that was recruited for this study read and signed an informed consent agreement that was specifically developed for this experiment after IRB approval was obtained for the study. Each participant's identity was kept confidential and numbers were used to refer to them. The height, weight, thigh length, shank length, and gender of each participant were collected, and after the completion of the experiment all data not needed was destroyed.

The first experimental design alternative was designed to have the participants perform all of their walking in one session. The participants would come into the lab on one day and perform their normal walking across the force plate so we can obtain a reading. We would record all of their data. After this, we would provide a short information session on racewalking and demonstrate to all of the participants how they should racewalk. The participants would then have a short practice session and then be

asked to racewalk across the forceplate. This data would be recorded. After this, all the participants would be free to leave.

The second experimental design that we developed would take place over one week. On the first day the participants (both those who know how to racewalk and those that do not) would come into the lab and perform their normal walking gait across the force plate. Their data would be recorded and they would be sent home. Those that did not know how to racewalk would be advised to learn the proper racewalking strategies on their own through recommended videos and online tutorials. All participants would be asked to return to the lab one week later to perform their racewalking across the forceplate. This data would be recorded.

The third experimental procedure that we developed would take place over one week. We would divide the group into two sections, those that knew how to racewalk and those who did not. Participants that did not know how to racewalk would come into the lab on one day and we would record that data we obtain from them walking across the force plate with their normal walking gait. We would then offer them an information session on racewalking and demonstrate how they should perform this sport. They would be given time to practice and be asked to return to the lab after one week. The group that knew how to racewalk would not be given the information session and would be asked to return to the lab after one week to perform their racewalking across the force plate.

Choosing the Final Experimental Design

The final experimental design was chosen based on the amount of time we had to gather our data and the amount of time we had to use the designated lab space. Since there are several groups using the same computer and using the same lab area, it was very important that we gathered our data in a short amount of time. However, still we kept in mind that the data must be accurate and gathered in a scientifically professional manner.

In the end, we chose to have all our participants come into the lab one day and both walk and racewalk, as explained in the first experimental design alternative. Participants were coached and observed to ensure they had the basic skills and rules of racewalking learned.

Methods for Measuring Body Angles

For every participant in our study we had to determine the angle of their ankle, knee and hip when they landed on the force plate. We also needed to determine specific lengths of their shank and thigh to determine their center of gravity. To do so, we recorded a video of each participant using a standard home video camera and

analyzed the frames to gather the angles. The lengths were measured in person at the time of the experiment since they did not change with gait.

The center of gravity was determined using the model set up by Chandler et. al.¹⁵ which was mentioned previously. This was calculated so the accelerometers would be placed in the proper position on the person's leg.

LabVIEW

LabVIEW Overview

LabVIEW, a National Instruments graphical programming software, allows the user to build custom user interfaces and programs, called virtual instruments (VIs), and acquire data from analogue signals.

Programming in LabVIEW consists of placing pictures representing certain functions and objects in the programming environment (block diagram) and then wiring them together. All objects used will show up in a corresponding window (graphical user interface) as if they were in the real world.

Using National Instruments hardware including but not limited to SCXI-1322 screw terminals, SCXI-1000 signal conditioning chassis, and SCXI-1122 signal conditioners, an analog signal such as change in voltage can be converted into a digital

signal which can then be read by a computer. A VI can be programmed to read this digital signal and output data to a spreadsheet or Microsoft Word document.

Our Virtual Instrument

LabVIEW 8.5 was used to collect the data from the force plate. Figure 12 shows the block diagram of the VI used to write the raw data that were taken from the strain gages in the force plate. These data were outputted as a waveform chart and also written to a Microsoft Excel file.

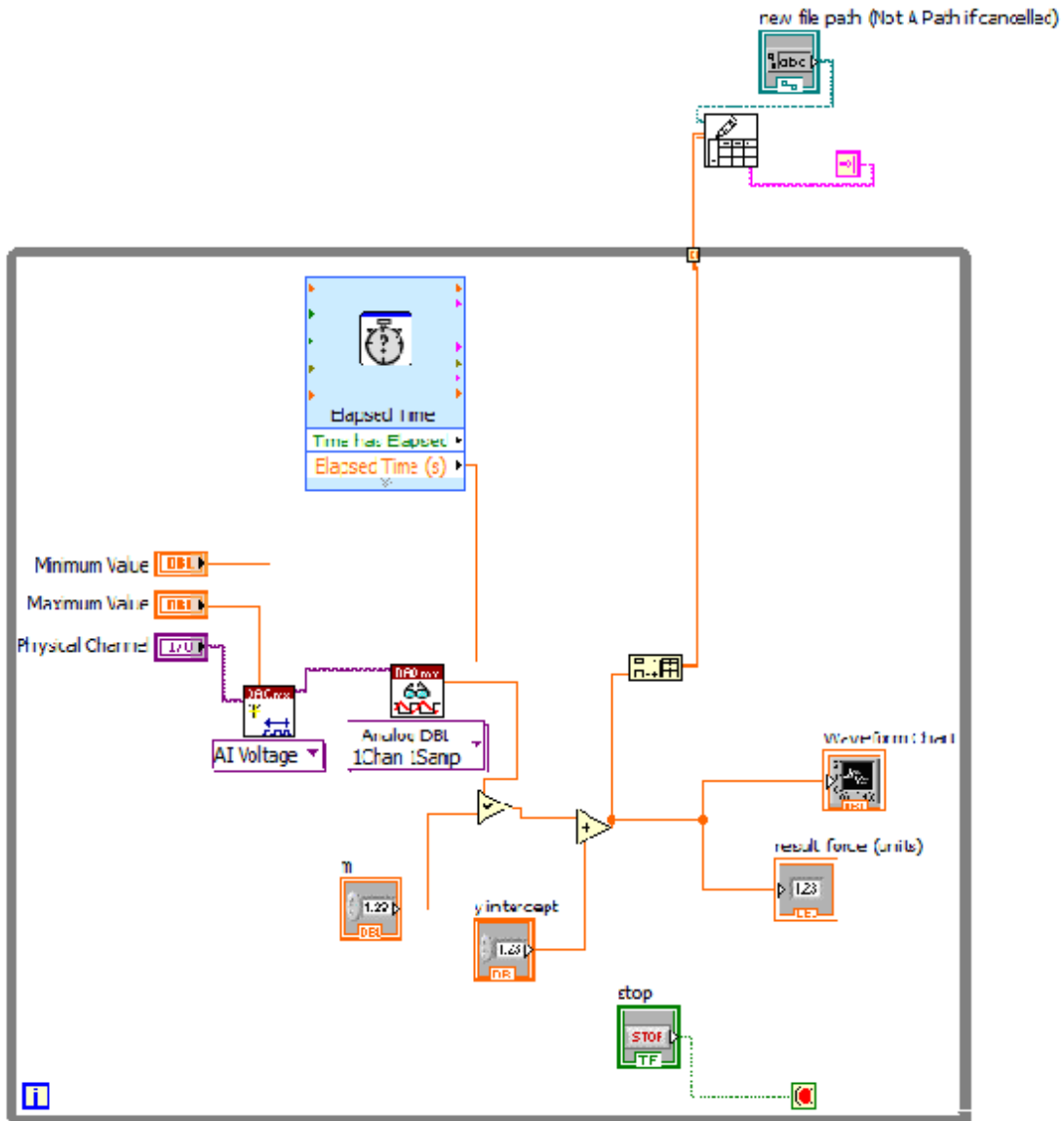

Figure 12: labview vi

The VI measured the change in voltage across the strain gauges in the force plate. This change of voltage was in the millivolt range. The VI was set to record about 120 samples per second and these data were then recorded as a number of millivolts and used in an equation to be discussed later in this paper to calculate the ground reaction force for each participant.

Force Plate Connections

The force plate was connected to a single channel on a SCXI-1322 screw terminal. The screw terminal was then used with a SCXI-1122 signal conditioner which was attached to a desktop computer in the Engineering Experimentation Lab in Higgins Laboratories on the WPI campus.

Methods for Determining Acceleration

Two methods were considered for the collection of accelerations: (1) using a camera; and (2) using accelerometers. Both methods have strengths and weaknesses and were explored extensively during this project.

Camera

To determine acceleration using a camera, video tape the object (for our purposes we would be looking at the center of mass of the leg) moving in front of a calibrated scale and play back the video one frame at a time. During playback measure the distance traveled in each frame using the scale. The average speed of a video camera is 25 frames per second and therefore the time between frames is 0.04 seconds. Using the measurements and what is known about the camera speed, calculate the average velocity of the object between frames using the equation:

$$\text{velocity} = \text{distance moved between frames} / (0.04 \text{ seconds})$$

Repeat the process for several consecutive frames and plot velocity versus time. The acceleration is equal to the gradient of the graph.¹⁸

While attempting this process we found that the video that we were taking was not easy to work with and the process was very time consuming. The video was of poor quality and therefore it was very hard to get the small changes in distance per frame. Using a camera became a backup option to accelerometers.

Accelerometers

Accelerometers can easily transmit information about the magnitude and direction of accelerations. BIOPAC accelerometers were available to us so we chose to use these to gather our data. We could choose between two accelerometers both of which measure in the X, Y, and Z directions: a 5g and a 50G. The 5g is suited to measure slower movement and for this reason we chose to use it to collect acceleration data. Using BIOPAC software the acceleration data can be plotted versus time in real-time, however the accelerometers can and do pick up outside noise from movement and reaction forces.

BIOPAC

BIOPAC Overview

BIOPAC refers to BIOPAC Systems, Inc. and its two products, the MP100 hardware system and *AcqKnowledge* software. Both products are used in conjunction to acquire data from real world applications, such as accelerations and pressures, in a similar way to LabVIEW.

The MP100 hardware system gathers an analog signal, converts it into a digital signal, and then feeds it to the computer where it can be read by the *AcqKnowledge* software. Within the software there is the ability to acquire and graph the signal in any interval, over any length of time, and have it record in any unit. Similar to LabVIEW the data can then be saved to a text file.

Unlike LabVIEW which can acquire signal from almost anything as long as it can be wired to the system, only BIOPAC products, designed specifically to interact with the MP100 hardware, can be used to acquire data.

BIOPAC Accelerometers

Accelerometer Setup

The BIOPAC accelerometers are high-level output transducers with a built in amplifier. The accelerometers are tri-axial and measure acceleration in the X, Y, and Z

directions simultaneously. The type of accelerometer used in this project was the TSD109C (5g).

Other hardware needed for this setup is the MP100 starter system, the HLT100A high level transducer module, and the UIM100A universal interface module (power source). The HLT100A is connected to the UIM100A and the three outputs from the accelerometers are each connected to their own input channel on the HLT100A (X-axis to channel 1, Y-axis to channel 2, and Z-axis to channel 3). *AcqKnowledge* version 3.3 is used to record the data.

Within the *AcqKnowledge* software there are many settings such as sample rate and scaling as well as channel setup. The sample rate was set at 120 samples per second to match the sampling rate of the LabVIEW VI so the data from both could be matched up for analysis and the length of run was set to 7 seconds. The scaling was used in the calibration of the accelerometer and channel setup allows for the user to decide how each channel is displayed. For our purposes we had one graph per output (X, Y, and Z) and plotted g versus time. The accelerometer itself was attached to a participant's center of mass of their leg (about lower thigh).

Accelerometer Calibration

BIOPAC has a set way to calibrate the accelerometers and this protocol was followed for this project using the MP100 System Guide provided by BIOPAC. After initial setup of the hardware, each channel had to be setup and calibrated within the

software. Select *Setup Channels* within the software MP100 menu and click on any of the chosen channels then choose *Scaling*. The subsequent dialogue box is used for calibration. Within the *Map Value* column the scaling factors of 1 and -1 were entered and the *Units label* was set to g. To calibrate the accelerometer the transducer was rotated 180 degrees through each axis and because each axis corresponds to one channel only one rotation was performed per calibration. The accelerometer was placed face up on a flat surface and the *Cal1* button was pressed. The transducer was then rotated 180 degrees and *Cal2* was pressed. This process was repeated for each channel.

To calibrate the Y-axis, the transducer was set face up on the table with the cord running left to right. It was then rotated 180 degrees away of the user (cord still running left to right). To calibrate the X-axis, the transducer was also set face up with the cord running left to right and then rotated 180 degrees without losing contact with the table. The cord ended up running right to left. To calibrate the Z-axis, the transducer was once again set face up with the cord running left to right. It was then flipped end on end so that it then rested face down on the table with the cord running right to left.

To test the calibration the BIOPAC protocol was followed. The sample rate was set to 50 samples per second and while the program ran the accelerometer was rotated through each axis. The vertical scale was set to 1 and the midpoint was set to 0 for each channel. The procedure was then repeated. The calibration was visually confirmed in accordance with the MP100 System Guide.

Accelerometer Problems

During data analysis we found that the accelerations gathered during each trial were significantly higher than any person could produce (in some cases up to 200g) and these readings were throwing off our muscle and joint force calculations. We traced this problem back to the accelerometer itself and attempted to do another calibration.

During this final calibration it was discovered that either the accelerometer or the MP100 hardware was malfunctioning as there was constant noise on both the X and Y channels (the only two channels we used for data) unlike previous calibrations. All three channels were also centered at 1g rather than 0g even after telling the system to disregard this difference and center all graphs at 0.

It was decided to try to normalize the data by dividing it by a factor. To find the factor a literature review was done to find average accelerations for both walking and racewalking. Because racewalking is very similar to running and also because there is little published research about the accelerations in racewalking, accelerations for running were used. Published findings state that the average acceleration of the leg while walking ranges from 1g to 5g and the average acceleration of the leg while running is plus or minus 10g.^{19,20,21,22}

For several participants the recorded accelerations during heel strike and toe off (the accelerations gathered while stepping on the force plate) were put into an Excel file. To determine the factor to divide the data by, the first value was taken from the acceleration in the X-direction and divided by each average velocity (walking: 1g, 1.4g,

2g, and 5g; racewalking/running: 7g, 8g, 9g, 10g, 11g). These calculations gave a number by which the data seemed to be multiplied by, assuming an average acceleration for each. The accelerations were then divided by these numbers and filled in to the Excel file. From these calculations it was decided that 2g and 10g were the appropriate accelerations to use for calculations.

However, when these normalized accelerations were substituted in to the original Excel file for calculations of the ground reaction force, muscle force, and joint force on the hip, it was found that most of the values for the forces on the hip were still extremely high (in the thousands). Upon further analysis it was found that the lower the acceleration in the Y-direction, the more appropriate the forces on the hip were (in the hundreds). The accelerations in the Y-direction were ignored during normalization because they already fit the range of average acceleration (0g-10g). It was further found that the areas with the highest and most erratic forces on the hip were during heel strike. This could be due to higher accelerations encountered from the impact of the foot hitting the ground. It can be assumed that the forces on the hip would be greater during heel strike because this is the point when the weight of the upper body is being put on the one leg, but the calculated muscle and joint forces were still in the range of thousands.

Calibration of Force Plate

Calibration of the force plate was very important because the calibration determined how to convert the raw data into a usable number. The way the force plate worked was it took a change in force (when someone walked across the plate) and converted it to a change in voltage. The LabVIEW program created would display a graph of Voltage Output vs. Time. We would then need an equation to convert this voltage output into a force we could use to calculate joint and muscle forces.

The equipment needed to calibrate the force plate was the force plate itself, the LabVIEW program and all hardware associated with that and various known weights (we used free weights). The procedure for calibration was as follows: first, the force plate was connected a computer through the data acquisition system, which was connected to LabVIEW. First, a five pound weight was placed on the force plate and a reading was recorded in Excel. Then, a ten pound weight was placed on the force plate and a reading was recorded in Excel. This was done in five pound intervals until ninety pounds was placed on the plate. Three trials were done and an average of all three trials was taken. A graph was generate from these numbers which related voltage output to force and a trendline and equation for this trendline was generated. The graph of the average data collected from this calibration can be seen below in Figure 13. The equation used to convert the voltage output to force was

$$\text{Ground Reaction Force} = 1095 * \text{mV} - 40 \quad \text{Equation 3}$$

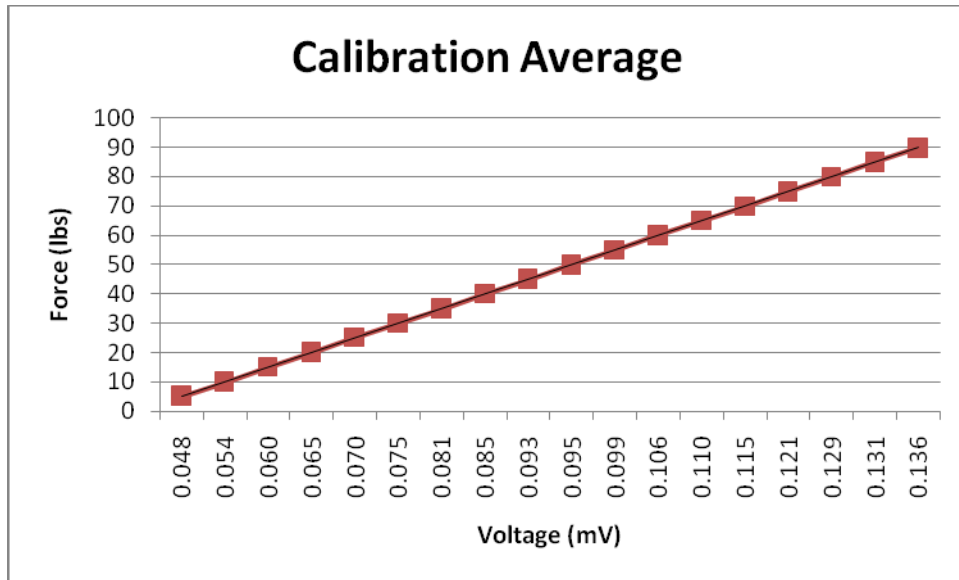

Figure 13: calibration curve

Excel File Used in Organizing and Calculating Participant Data

All data from the force plate and accelerometer were put into a Microsoft Excel file for each participant. The file included the following information:

- Time for each run
- Force plate readings in millivolts
- Accelerations in the X and Y directions
- Ankle angle, muscle angle, hip angle, joint angle, weight of limb, and weight

- Calculated ground reaction forces and forces on the hip muscle and joint

Full advantage was taken of the Formula feature in Excel. The formulas to calculate the ground reaction force and the forces on the hip were plugged in to each spreadsheet. The formulas are as follows:

- Ground reaction force (example)

$$=(1095*B3)-40$$

- Force on the hip muscle (example)

$$=-((F3*\text{SIN}(90-\$G\$4)-\$I\$4*\text{SIN}(\$J\$4)-\$L\$4*C3-\text{TAN}(\$H\$4)*(F3*\text{COS}(90-\$G\$4)-\$I\$4*\text{COS}(\$J\$4)-\$L\$4*D3))/(\text{COS}(\$H\$4)*\text{SIN}(\$K\$4)-\text{COS}(\$K\$4)*\text{TAN}(\$H\$4)))+((F3*\text{COS}(90-\$G\$4)-\$I\$4*\text{COS}(\$J\$4)-\$L\$4*D3)/(\text{COS}(\$H\$4)))$$

- Force on the hip joint (example)

$$=(F3*\text{SIN}(90-\$G\$4)-\$I\$4*\text{SIN}(\$J\$4)-\$L\$4*C3-\text{TAN}(\$H\$4)*F3*\text{COS}(90-\$G\$4)-\$I\$4*\text{COS}(\$J\$4)-\$L\$4*D3)/(\text{SIN}(\$K\$4)-\text{COS}(\$K\$4)*\text{TAN}(\$H\$4))*-1$$

Excel was also used to graph Ground Reaction Force versus Time, Force on the Hip Joint versus Time, and Force on the Hip Muscle versus Time. These graphs helped to solidify that we were on the correct track with our data because they resembled graphs that can be found in literature on gait analysis.

Data Evaluation Methods

Once all of the data was collected and organized into an excel file, it was evaluated to determine the ground reaction force curve for each participant, the forces at heel strike for each participant, the maximum ground reaction force for each person, and ultimately, the maximum hip muscle and hip joint forces.

First, the time where the participant was in contact with the force plate was graphed against time for both walking and racewalking. The curves for walking generally resembled the one shown in figure 14 below. The curves for racewalking for each participant generally looked like figure 15 below. These graphs have reasonable shapes that resemble other gait analysis studies however, the forces are too low.

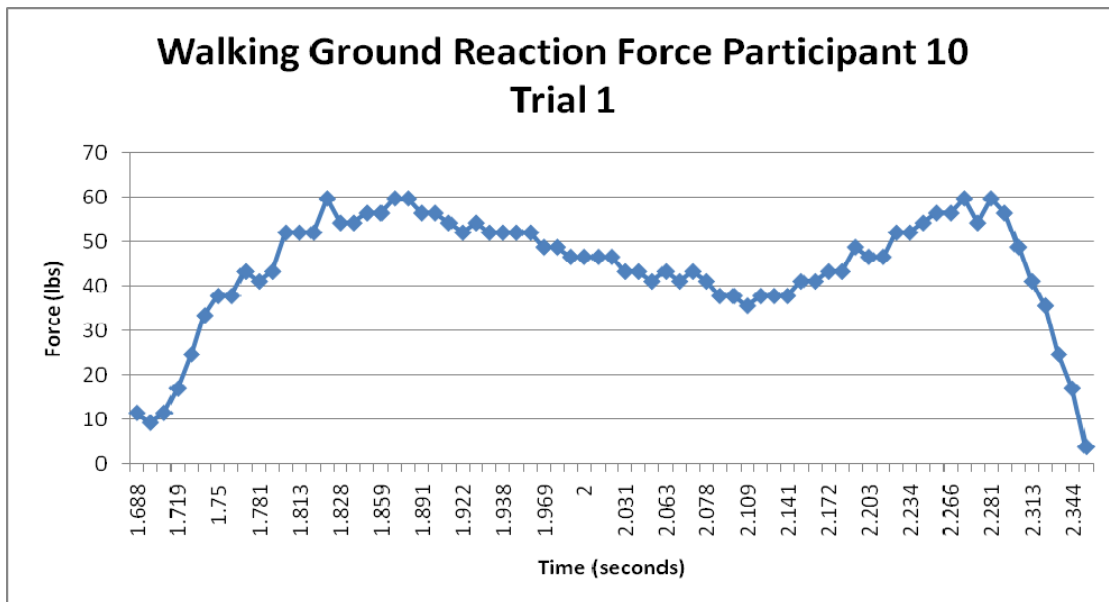

Figure 14: GRF Walking curve

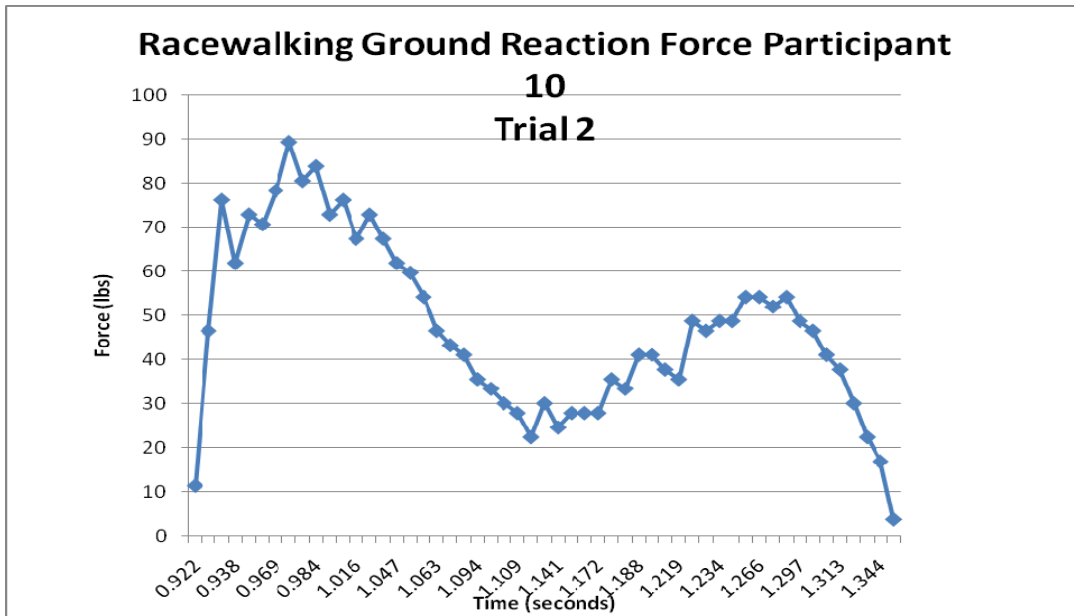

Figure 15: GRF Racewalking curve

These curves were used to determine the time interval where the “heel off” phase of the gait cycle was occurring. The heel off phase was then plotted against time for both walking and racewalking. These curves resembled figures 16 and 17 below.

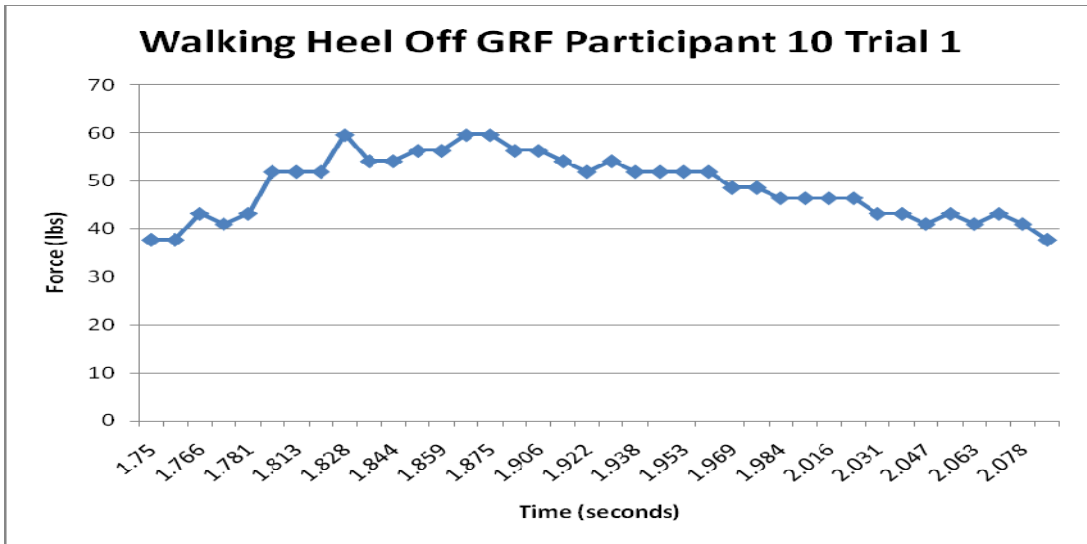

Figure 16: Heel off phase of walking

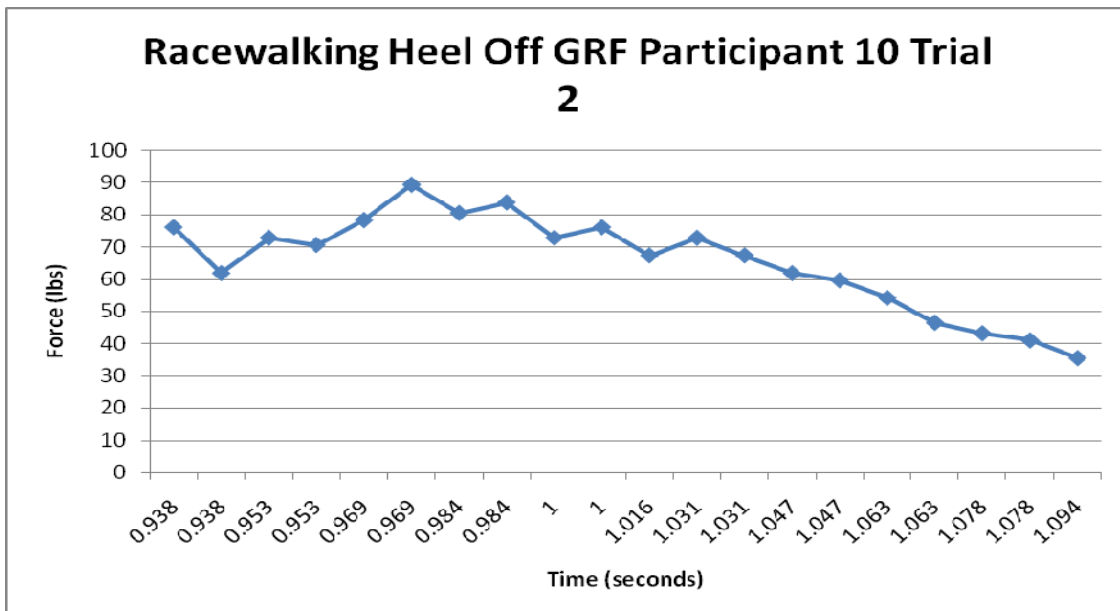

Figure 17: Heel off phase of racewalking

From the heel off graphs it was then determined where the maximum ground reaction force (GRF) occurred in relation to time. The muscle force and joint force for this instance in time was then found using the excel file generated. Each participant's maximum GRF and relative joint and muscle forces were compiled in a separate excel file to determine the averages of the forces.

Results

Once the data was evaluated and the averages were compiled, the results were graphed in Excel. The individual peak muscle and joint forces for each participant can be seen in Figures 18 and 19, respectively.

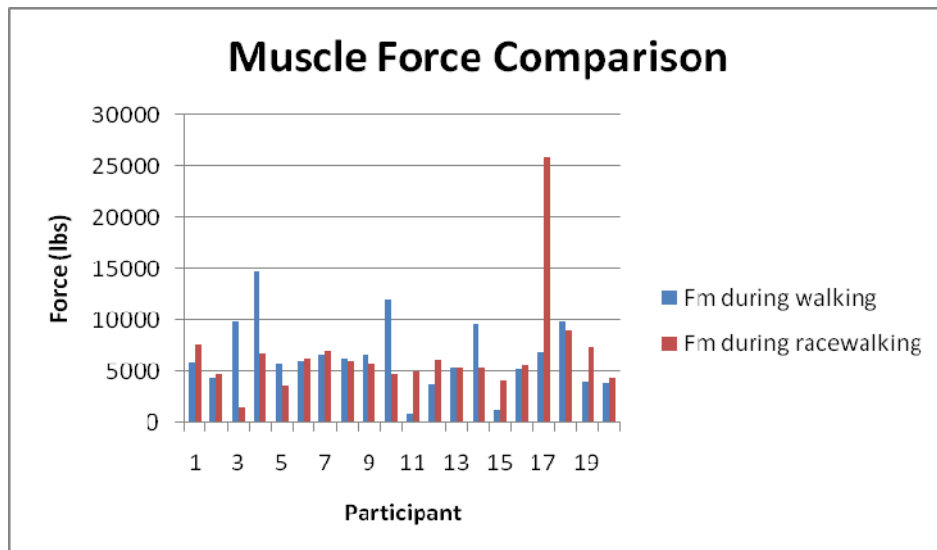

Figure 18: Average muscle forces

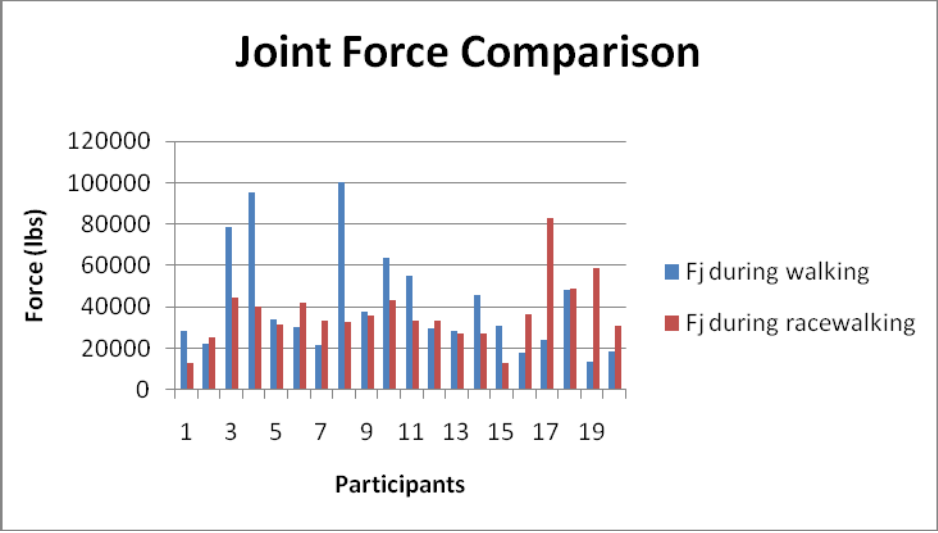

Figure 19: average joint forces

In Figure 20 below, one can see the average reaction forces in the muscle for all participants. In figure 21 below, the average reaction forces in the hip joint for all participants can be seen.

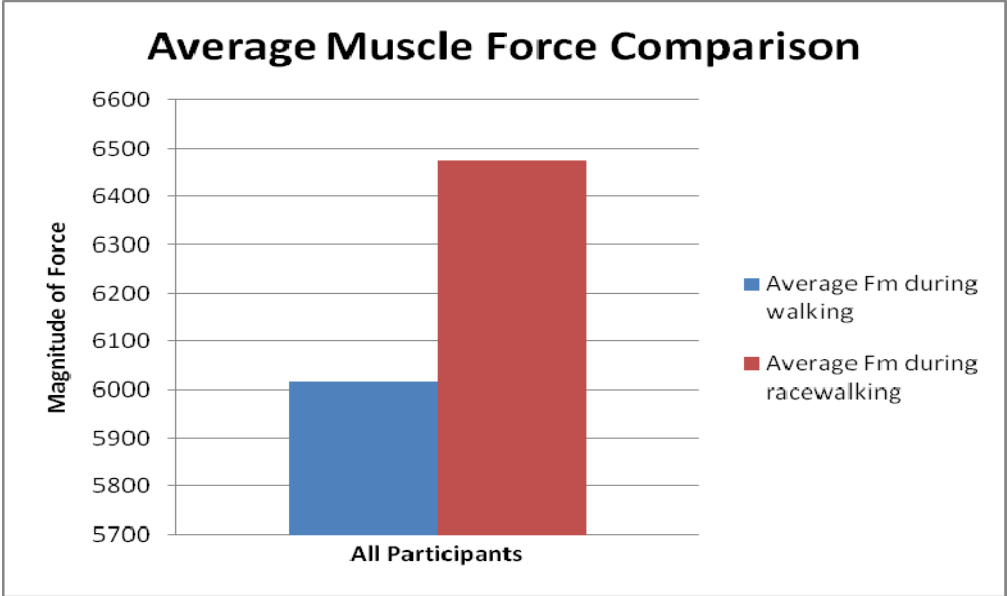

Figure 20: average Muscle force of all participants

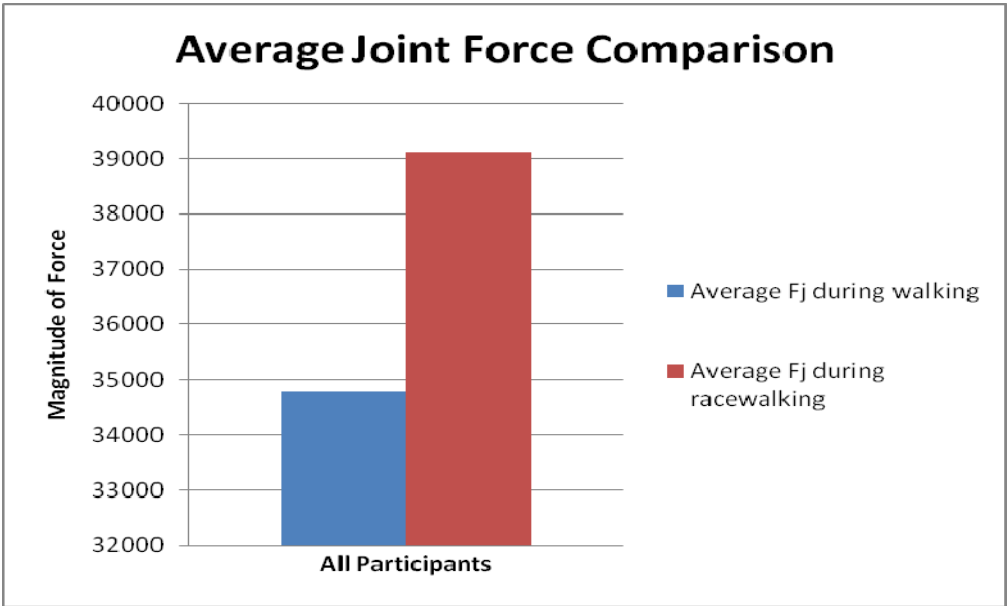

Figure 21: average joint forces of all participants

One can see from the charts that there is a very large y scale. This is a result of an error somewhere in calibration of the accelerometers and potentially somewhere else in the experiment. The data is all proportional and one can see that overall, the muscle and joint forces in racewalking are greater than in regular walking. There is an unknown factor that is multiplied in all of our data causing numbers to come out larger in calculation. Though it was attempted to find the problem and calibrations on the force plate and accelerometers were redone, there was simply not enough time to figure out the issue.

The design of a successful experimental procedure was accomplished as part of the project and could be used in further studies. It was also determined that the existing force plate used was suitable for the purposes of this experiment. Further calibrations and specifications tests on the force plate should be done to determine the sensitivity of it.

Conclusions

The preliminary data we collected does lend itself to a conclusion in favor of our original hypothesis, although a definite conclusion cannot be drawn from it for several reasons. Although the numbers are multiplied by an unknown factor that could not be determined, further data collection and evaluation would most likely reveal that muscle and joint forces of the hip are greater in racewalking than in regular walking. The data

also tends to show that overall, joint forces are much larger than muscle forces in the hip.

A statistical T test analysis was done for the muscle and joint force averaged data. A T test determines if the means of two different groups of data are statistically different from one another. The muscle forces for walking and racewalking were compared and the joint forces for walking and racewalking were compared. The p values were very large which means that the results gathered have a very large chance of being random. The p value for the muscle forces was 0.90 and the p value for the joint force was 0.49. The data is not statistically significant.

There are many places where there would have been a calibration error of some type. The force plate and accelerometers were recalibrated, but no specific problem could be determined. In the future, studies could be done that involved more participants and better equipment. This way, there would be more data to draw conclusions from and less potential for data collecting errors and difficulties, as were encountered in our study.

Appendix A

Calculations done in Mathcad of the joint and muscle equations. Variables were previously defined.

$$\Sigma F_x := -F_m \sin(\phi) - F_j \sin(\alpha) + F_g \sin(90 - \beta) - W \sin(\theta) - m \cdot a_x$$

$$F_m \sin(\phi) = \frac{-F_j \sin(\alpha) + F_g \sin(90 - \beta) - W \sin(\theta) - m \cdot a_x}{\sin(\phi)}$$

$$F_m = \frac{-F_j \sin(\alpha) + F_g \sin(90 - \beta) - W \sin(\theta) - m \cdot a_x}{\sin(\phi)}$$

$$\Sigma F_y := -F_m \cos(\phi) - F_j \cos(\alpha) + F_g \cos(90 - \beta) - W \cos(\theta) - m \cdot a_y$$

$$F_m \cos(\phi) = \frac{-F_j \cos(\alpha) + F_g \cos(90 - \beta) - W \cos(\theta) - m \cdot a_y}{\cos(\phi)}$$

$$F_m = \frac{-F_j \cos(\alpha) + F_g \cos(90 - \beta) - W \cos(\theta) - m \cdot a_y}{\cos(\phi)}$$

$$F_m := F_r$$

$$\frac{-F_j \sin(\alpha) + F_g \sin(90 - \beta) - W \sin(\theta) - m \cdot a_x}{\sin(\phi)}$$

=

$$\frac{-F_j \cos(\alpha) + F_g \cos(90 - \beta) - W \cos(\theta) - m \cdot a_y}{\cos(\phi)}$$

Solve for Fj

$$\frac{\sin}{\cos} = \tan$$

Multiply both sides by sin(φ)

$$\tan(\phi)(-F_j \cos(\alpha) + F_g \cos(90 - \beta) - W \cos(\theta) - m \cdot a_y) =$$

$$-F_j \sin(\alpha) + F_g \sin(90 - \beta) - W \sin(\theta) - m \cdot a_x$$

$$\frac{-F_j \cos(\alpha) \tan(\phi) + F_g \cos(90 - \beta) - W \cos(\theta) - m \cdot a_y}{-\tan(\phi) F_j \cos(\alpha) + \tan(\phi)(F_g \cos(90 - \beta) - W \cos(\theta) - m \cdot a_y)} =$$

$$\frac{F_g \sin(90 - \beta) - W \sin(\theta) - m \cdot a_x - \tan(\phi)(F_g \cos(90 - \beta) - W \cos(\theta) - m \cdot a_y)}{-F_j \sin(\alpha) + F_g \sin(90 - \beta) - W \sin(\theta) - m \cdot a_x}$$

65

$$F_j(\sin(\alpha) - \cos(\alpha) \tan(\phi)) =$$

$$\frac{-[F_g \sin(90 - \beta) - W \sin(\theta) - m \cdot a_x - \tan(\phi)(F_g \cos(90 - \beta) - W \cos(\theta) - m \cdot a_y)] \cdot \cos(\alpha)}{-[F_g \sin(90 - \beta) - W \sin(\theta) - m \cdot a_x - \tan(\phi)(F_g \cos(90 - \beta) - W \cos(\theta) - m \cdot a_y)] \cdot \sin(\alpha)}$$

$$F_j = \frac{-[F_g \sin(90 - \beta) - W \sin(\theta) - m \cdot a_x - \tan(\phi)(F_g \cos(90 - \beta) - W \cos(\theta) - m \cdot a_y)] \cdot \cos(\alpha)}{-[F_g \sin(90 - \beta) - W \sin(\theta) - m \cdot a_x - \tan(\phi)(F_g \cos(90 - \beta) - W \cos(\theta) - m \cdot a_y)] \cdot \sin(\alpha)}$$

$$F_m = F_j$$

Use the Fm equation coming from ΣFy

$$\cos(\phi) + \sin(\phi)$$

$$F_m = \frac{[-Fg \sin(90 - \beta) + W \sin(\theta) + m \cdot ax + \tan(\phi)(Fg \cos(90 - \beta) - W \cos(\theta) - m \cdot ay)] \cdot \cos(\alpha)}{\cos(\phi) \cdot (\sin(\alpha) - \cos(\alpha) \tan(\phi))} \quad \blacksquare + \blacksquare$$

$$\frac{Fg \cos(90 - \beta) - W \cos(\theta) - m \cdot ay}{\cos(\phi)}$$

$$F_m = \frac{(Fg(\cos(90 - \beta) \tan(\phi) - \sin(90 - \beta)) + W(\sin(\theta) + \cos(\theta) \tan(\phi)) + m(ax - \tan(\phi) ay)) \cos(\alpha)}{\cos(\phi) \cdot (\sin(\alpha) - \cos(\alpha) \tan(\phi))}$$

$$\blacksquare + \blacksquare \quad \frac{Fg \cos(90 - \beta) - W \cos(\theta) - m \cdot ay}{\cos(\phi)}$$

Appendix B

Calibration curves and data table for trials 1, 2, 3 and averages.

Force (lbs)	voltage (mV)	voltage (mV)	voltage (mV)	average voltage (mV)
5	0.046	0.049	0.049	0.048
10	0.054	0.054	0.054	0.054
15	0.059	0.062	0.059	0.060
20	0.067	0.062	0.067	0.065
25	0.071	0.069	0.069	0.070
30	0.074	0.074	0.076	0.075
35	0.079	0.081	0.084	0.081
40	0.084	0.086	0.086	0.085
45	0.093	0.093	0.091	0.093
50	0.093	0.098	0.093	0.095
55	0.101	0.098	0.098	0.099
60	0.108	0.106	0.103	0.106
65	0.108	0.110	0.110	0.110
70	0.115	0.115	0.115	0.115
75	0.118	0.123	0.123	0.121
80	0.128	0.132	0.128	0.129
85	0.130	0.130	0.132	0.131
90	0.137	0.135	0.137	0.136

Figure 22: calibration raw data

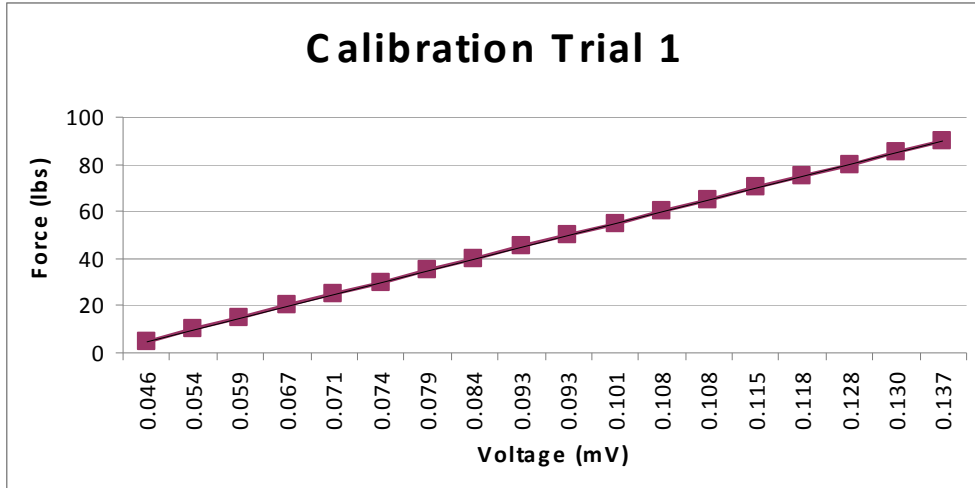

Figure 23: Calibration trial 1 data

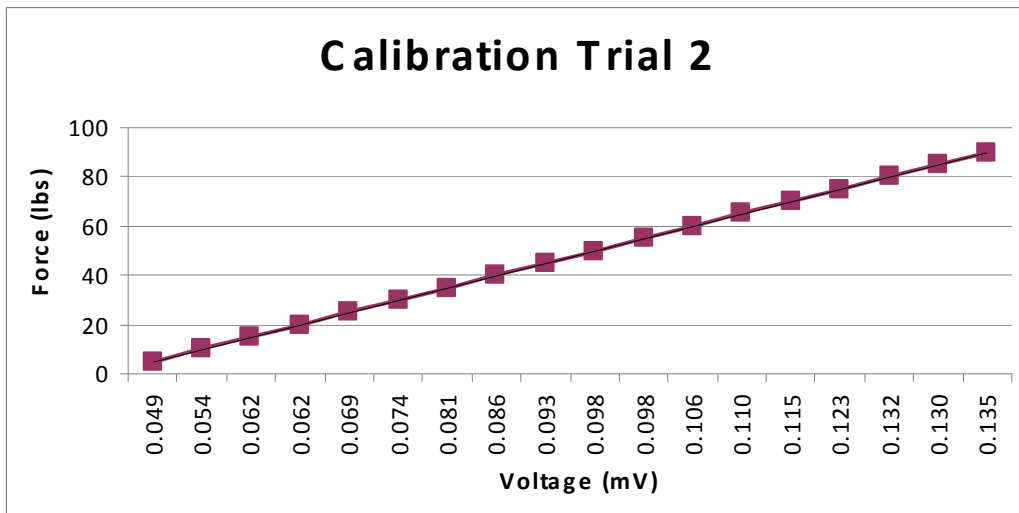

Figure 24: calibration trial 2 data

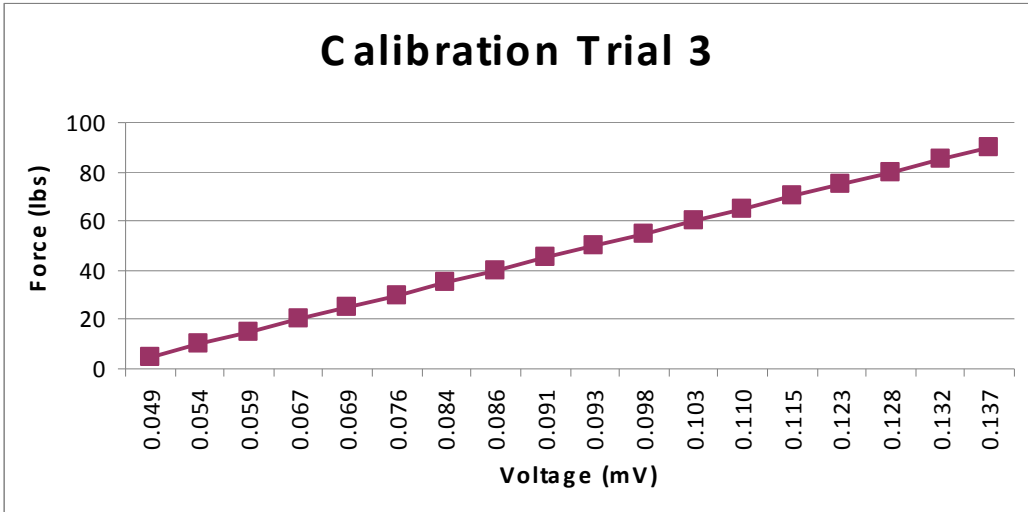
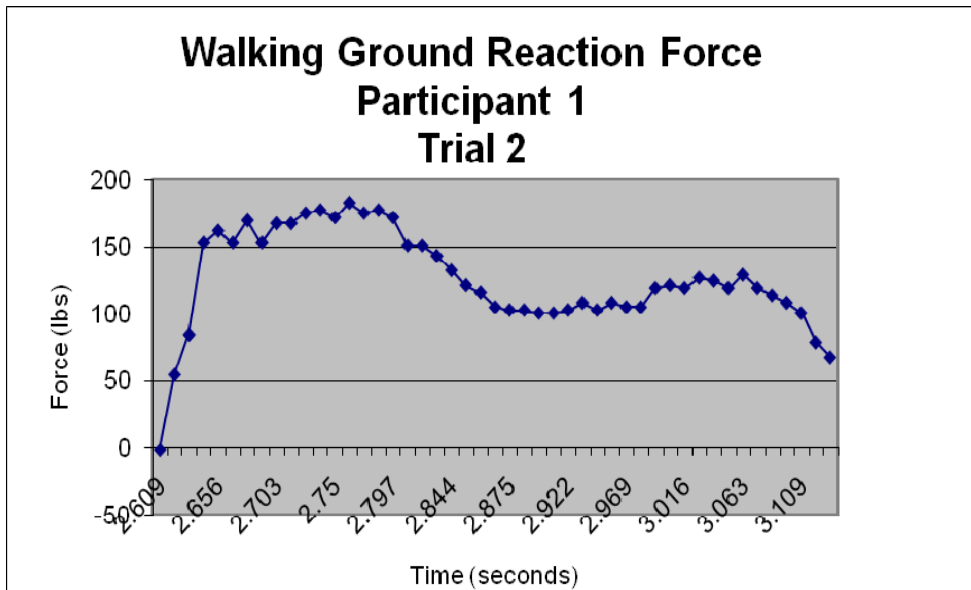
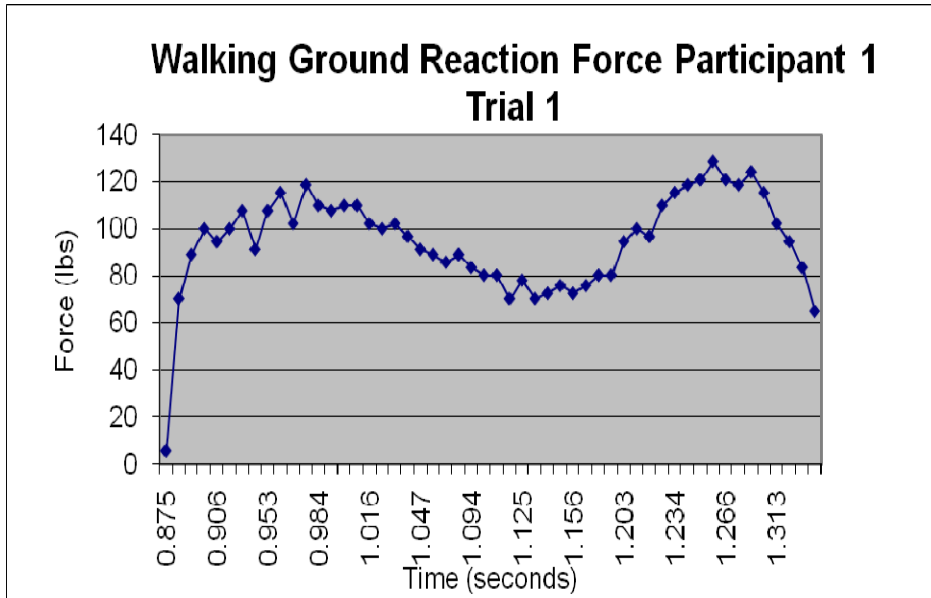

Figure 25: calibration trial 3 data

Appendix C

Raw data graphs organized by participant

Participant 1



Racewalking Ground Reaction Force Participant 1 Trial 1

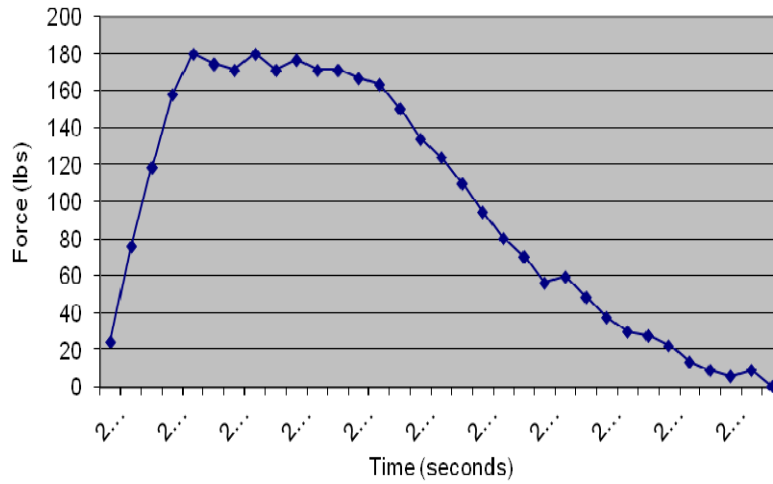

Racewalking Ground Reaction Force Participant 1 Trial 2

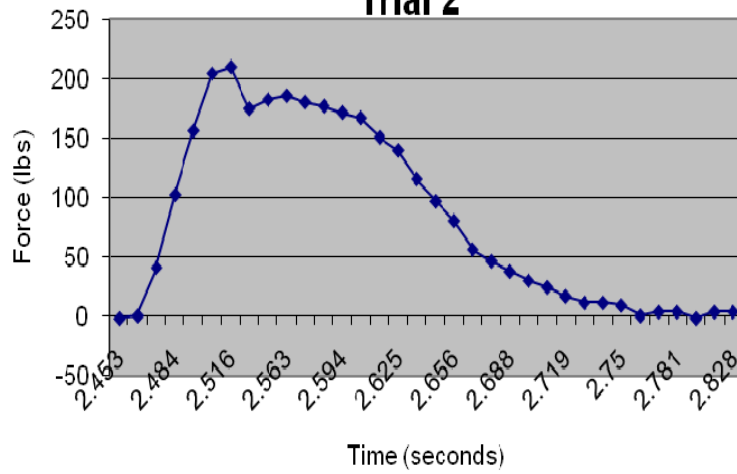

Participant2

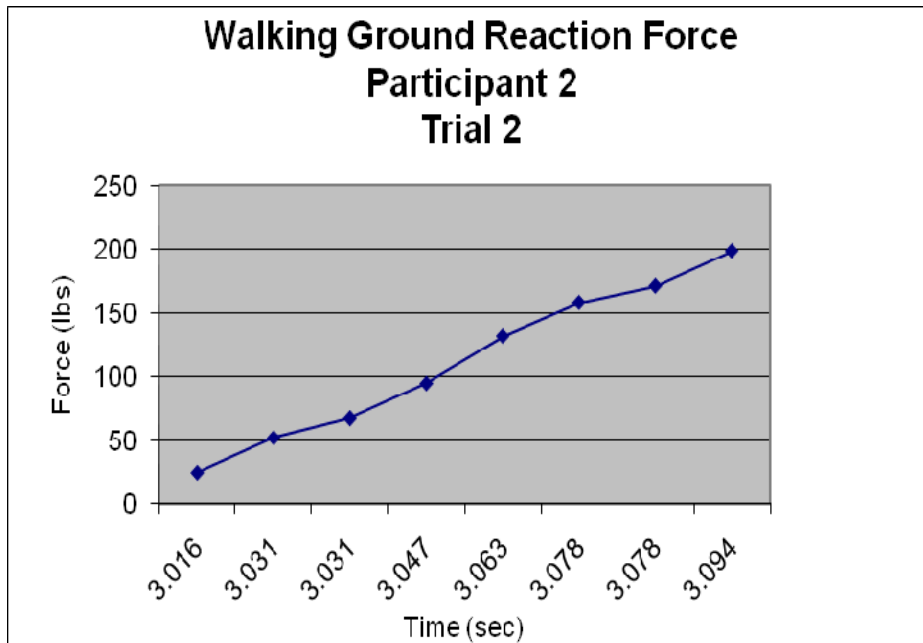
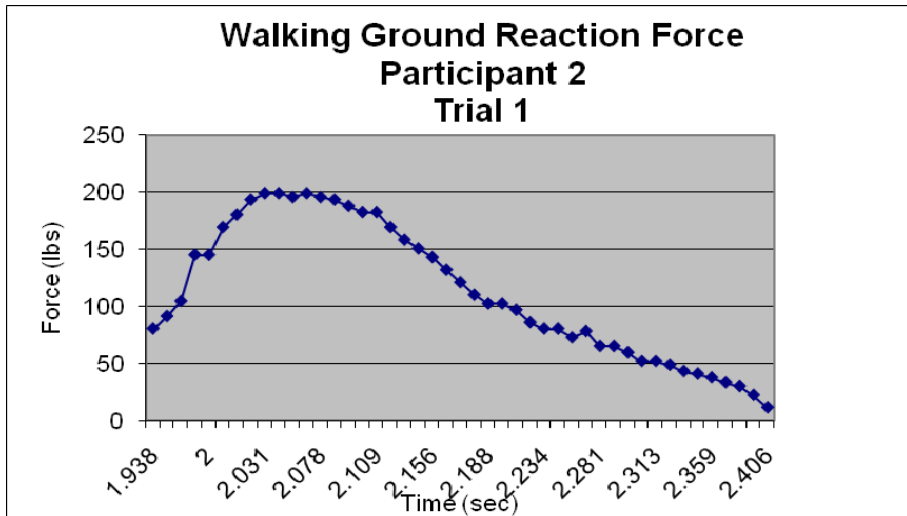

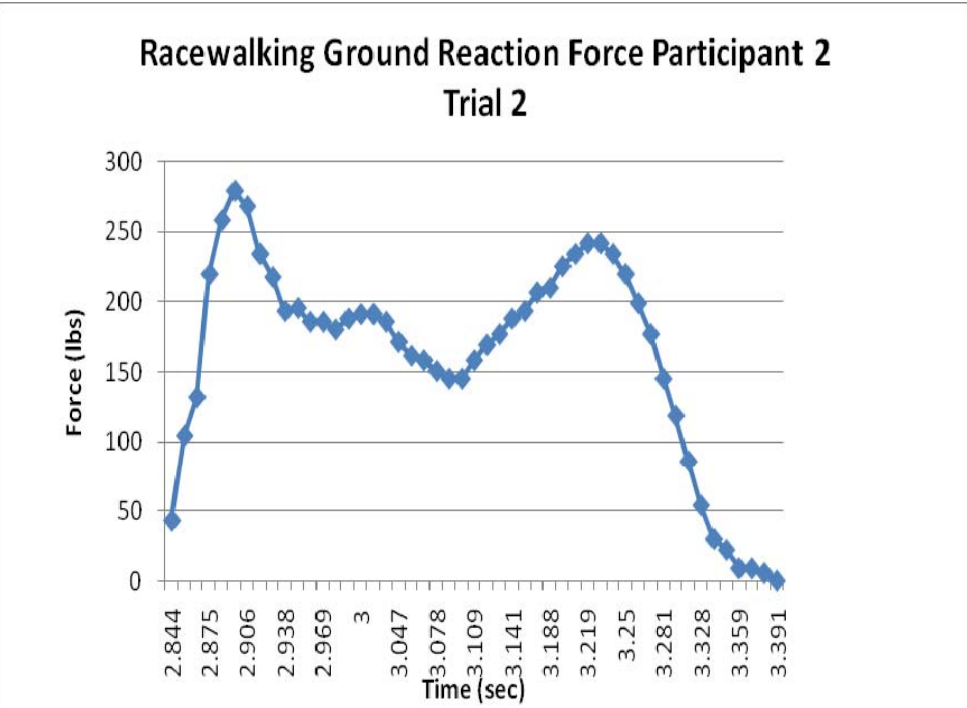
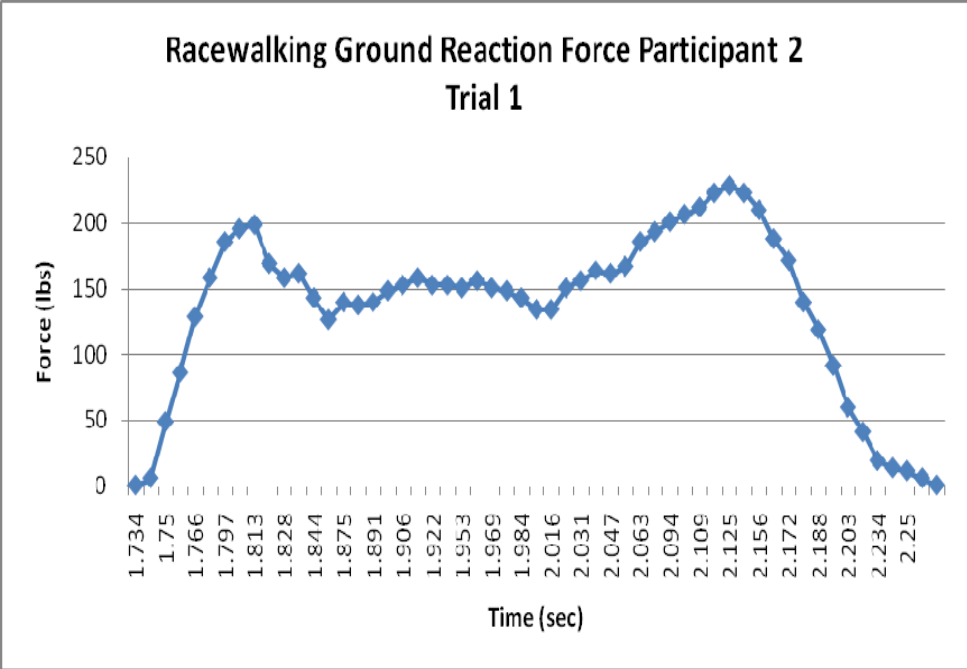

Participant 3

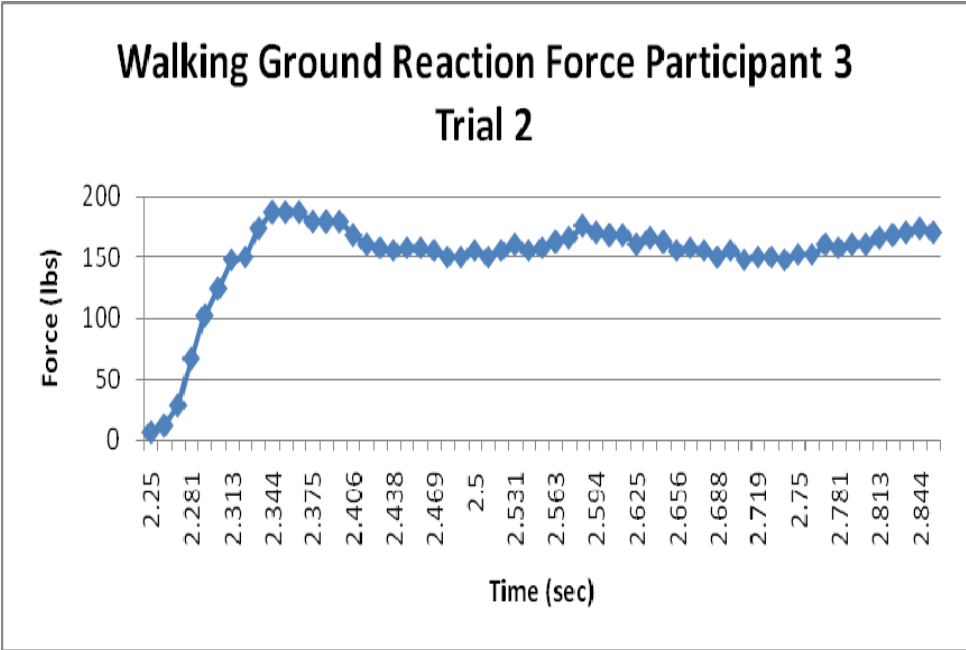
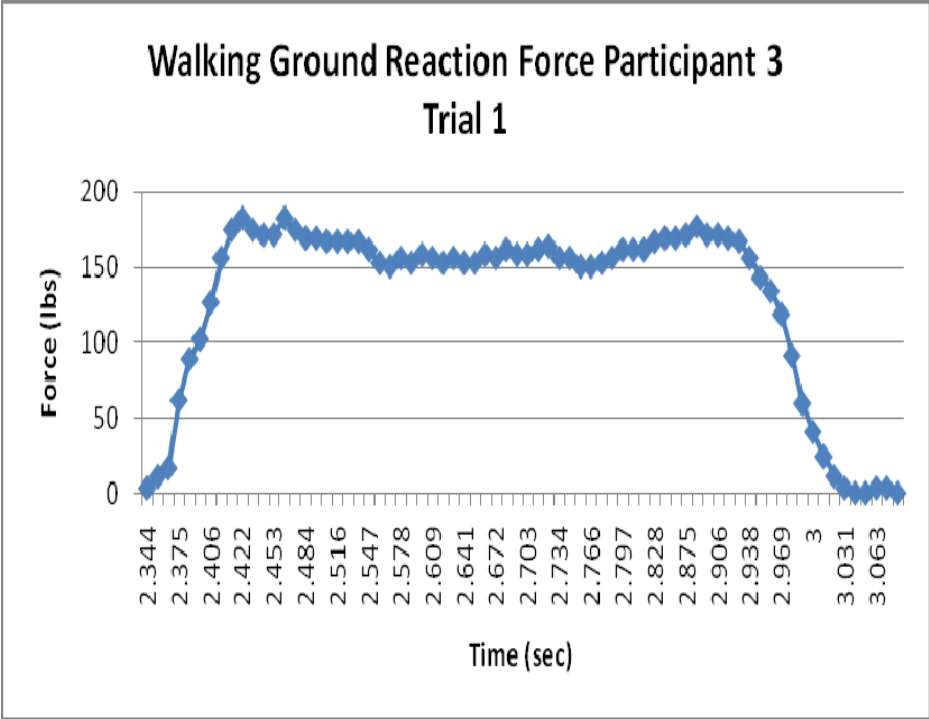

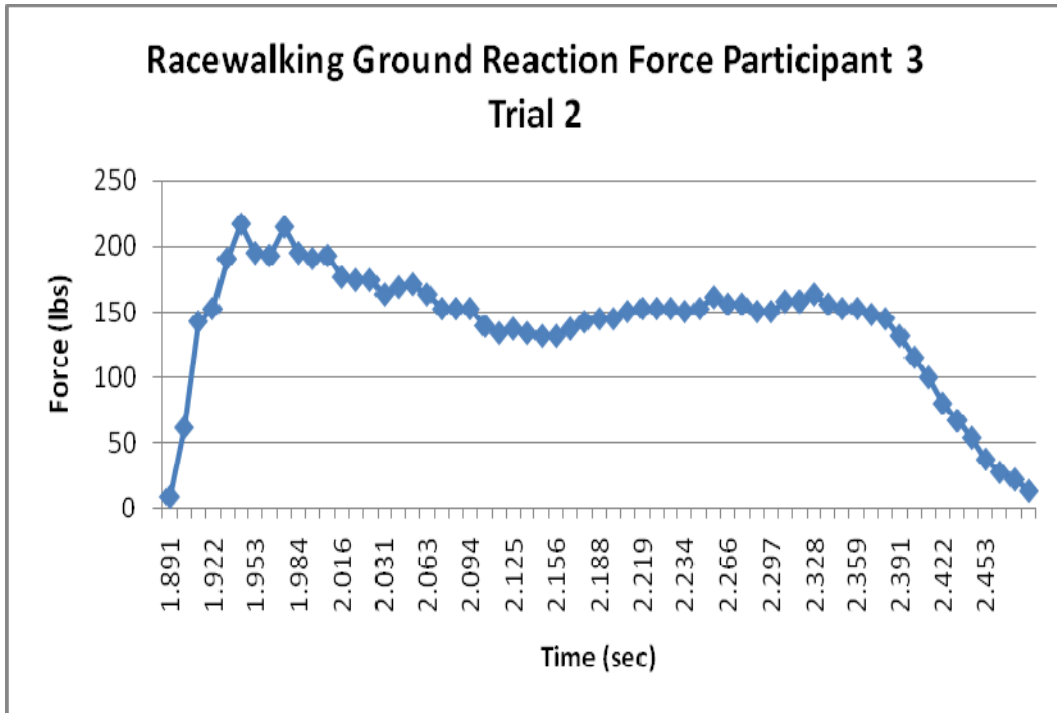
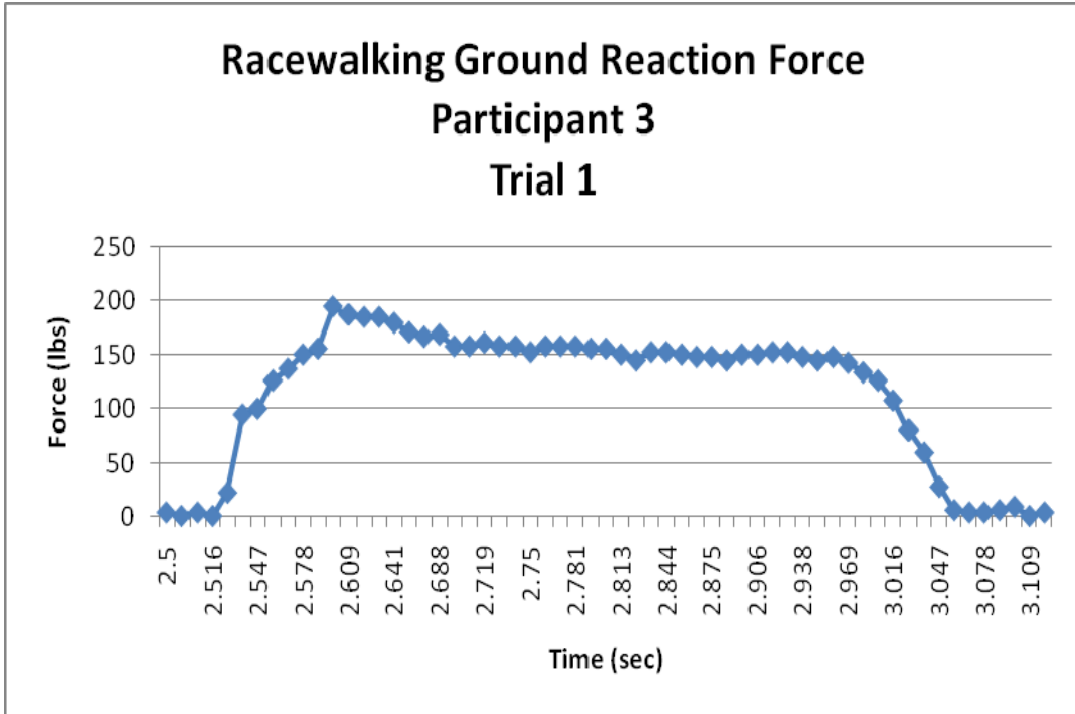

Participant 4

Walking Ground Reaction Force Participant 4 Trial 2

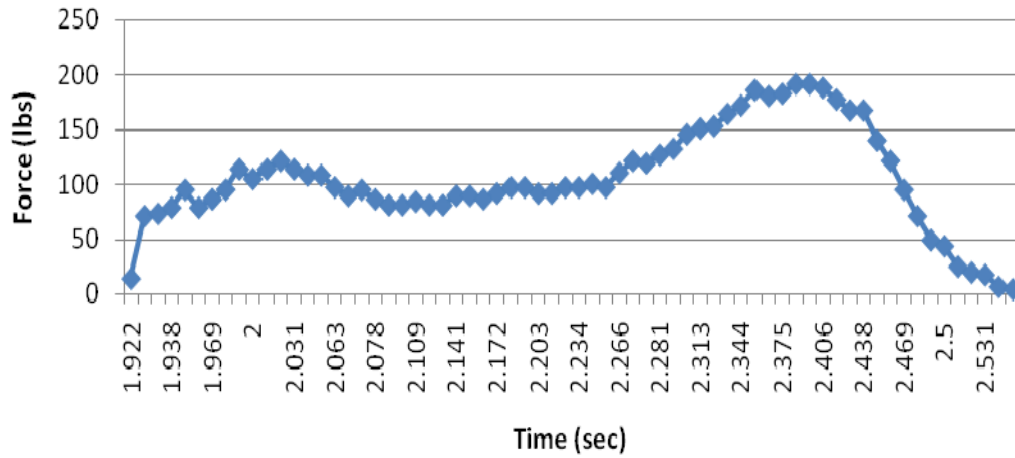

Racewalking Ground Reaction Force Participant 4 Trial 1

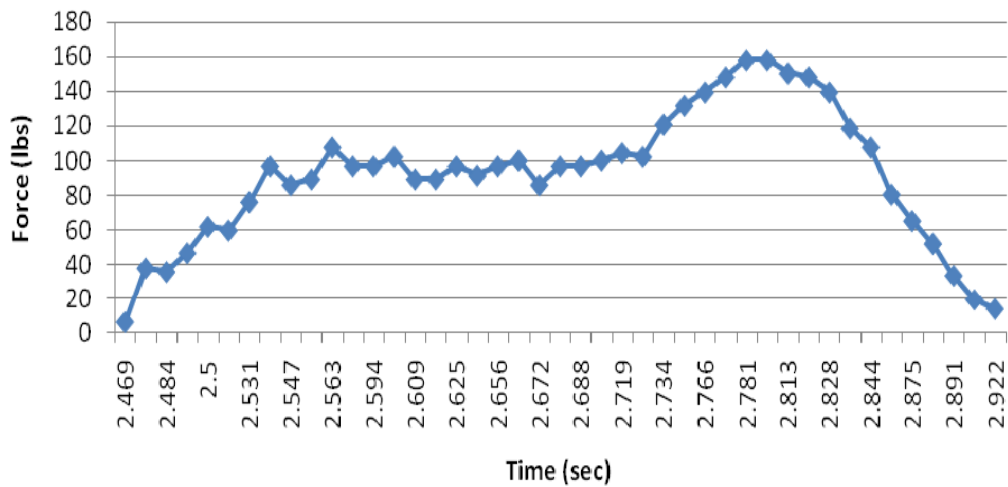

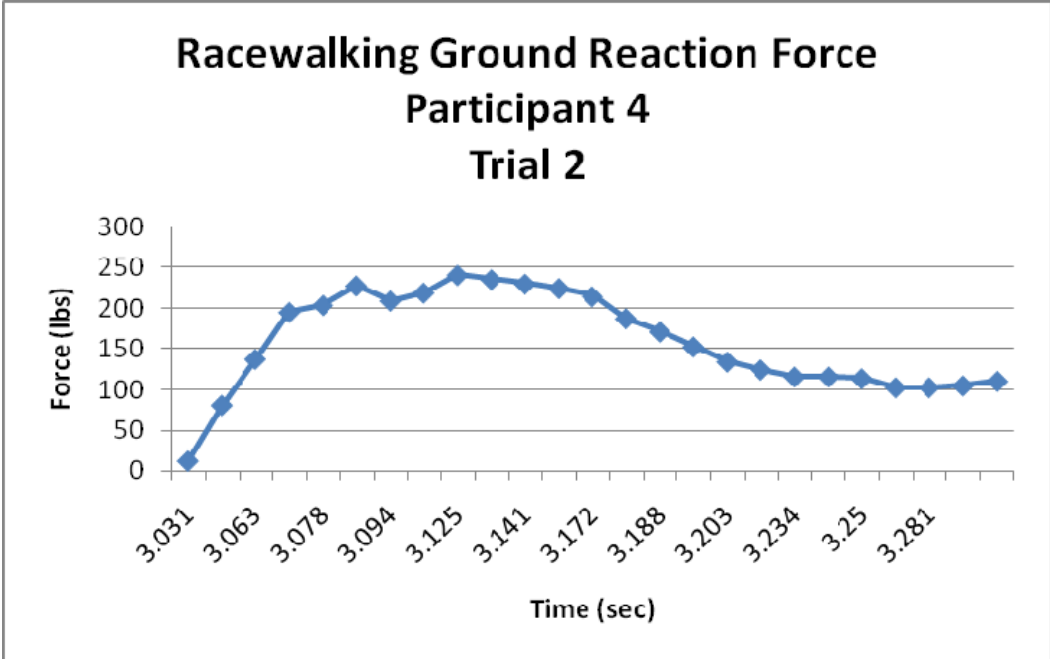

Participant 5

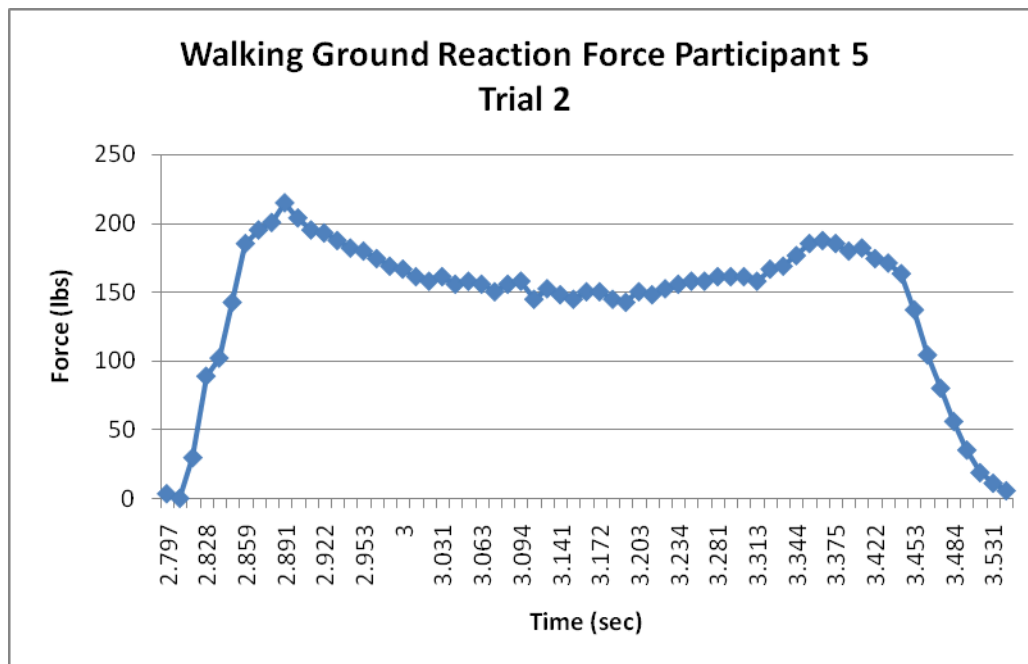
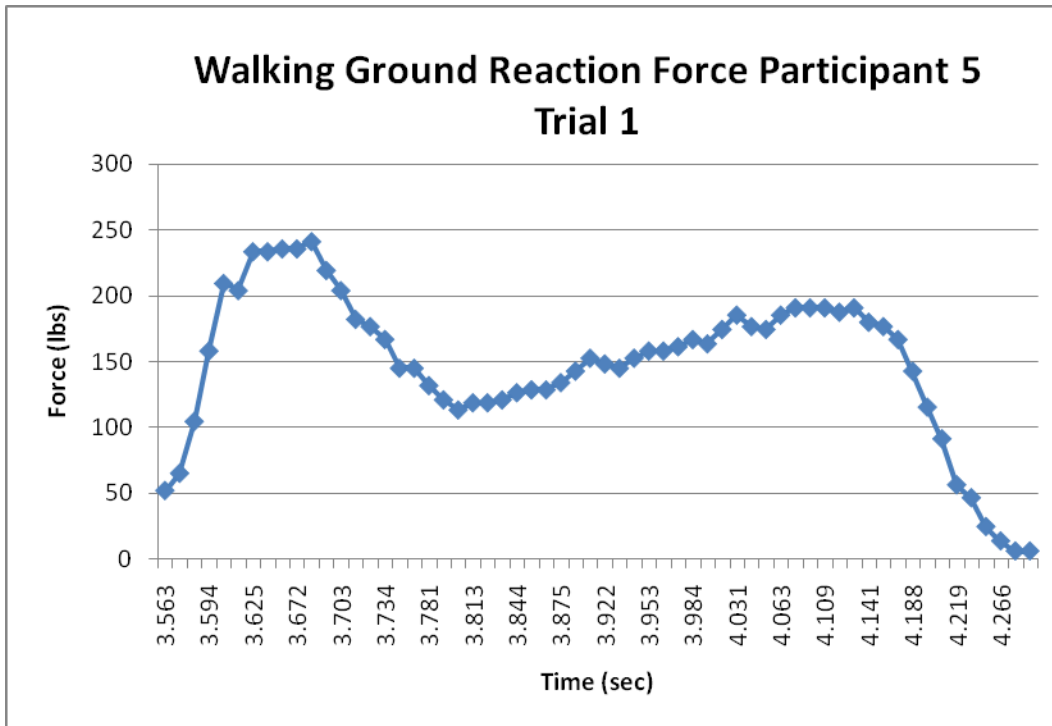

Racewalking Ground Reaction Force Participant 5 Trial 1

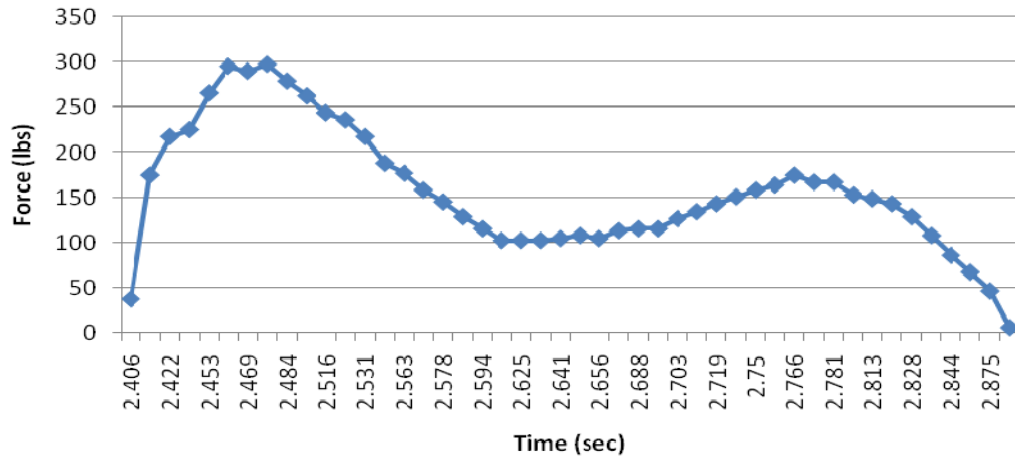

Racewalking Ground Reaction Force Participant 5 Trial 2

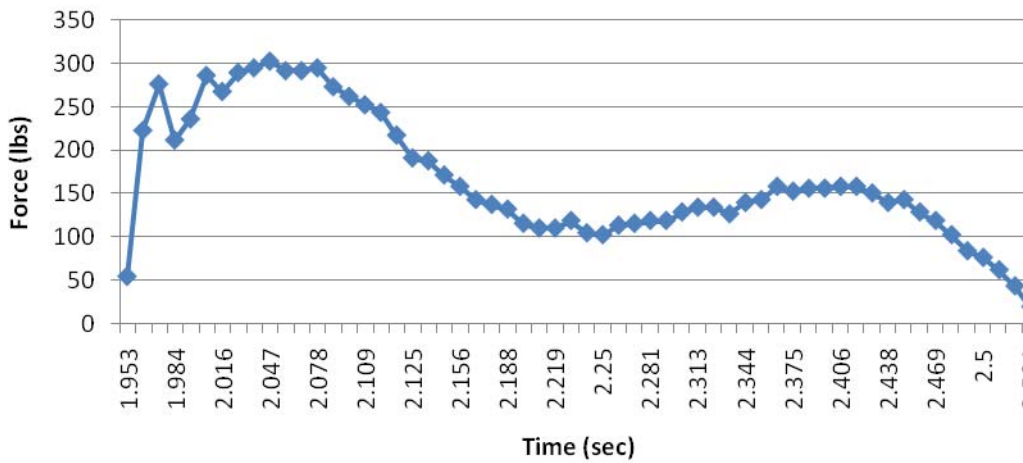

Participant 6

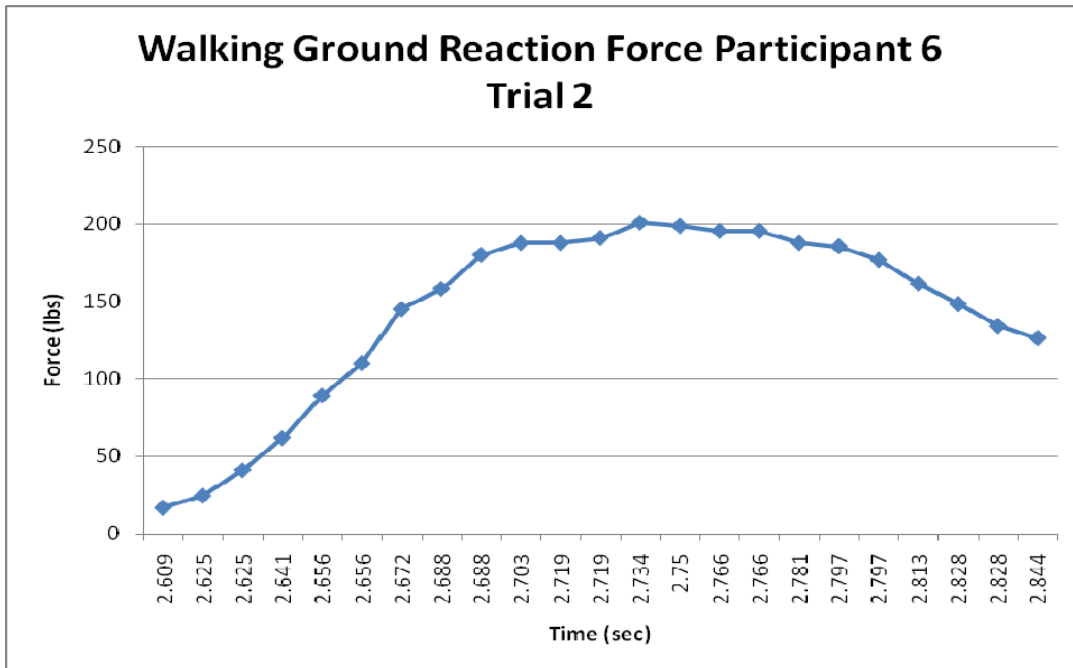
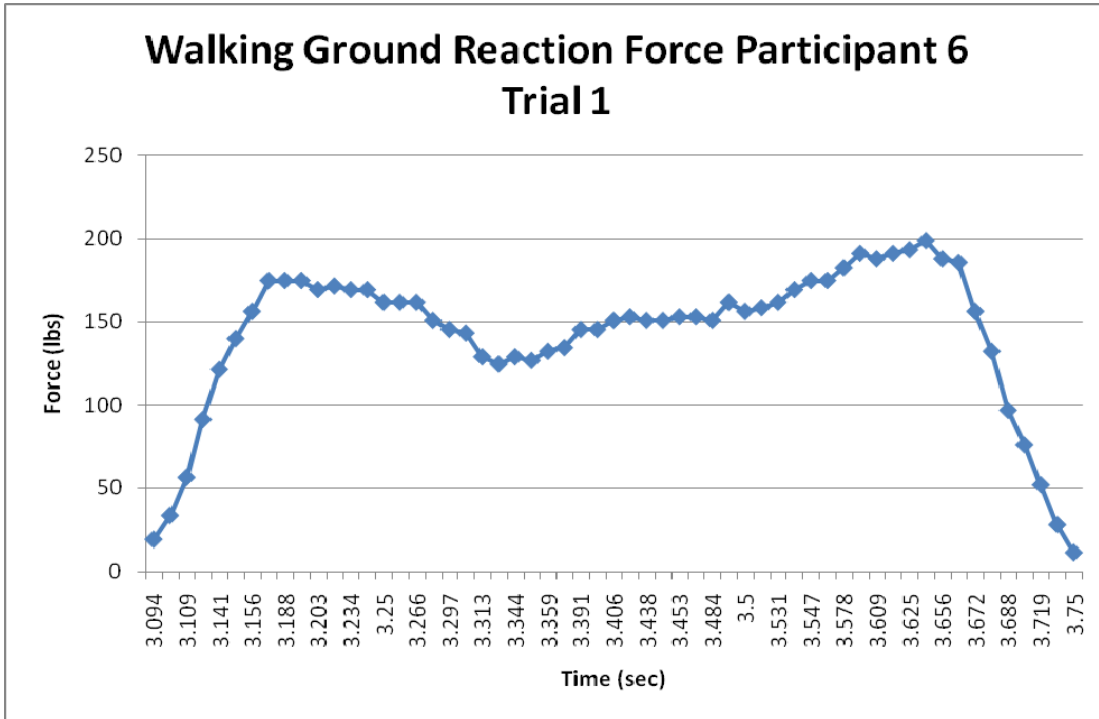

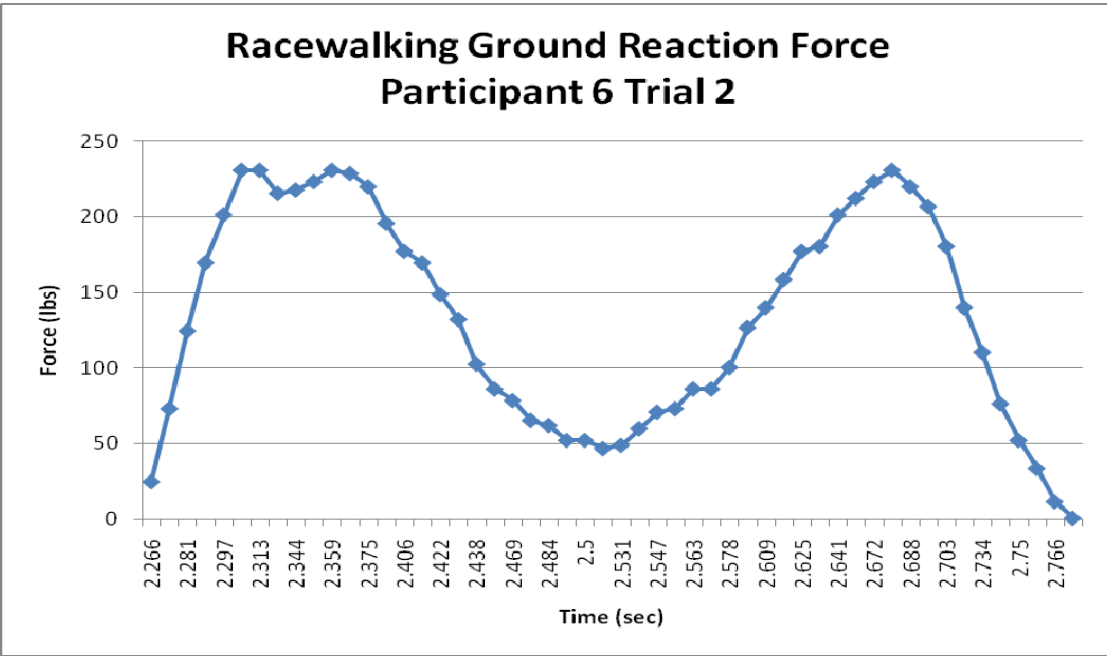
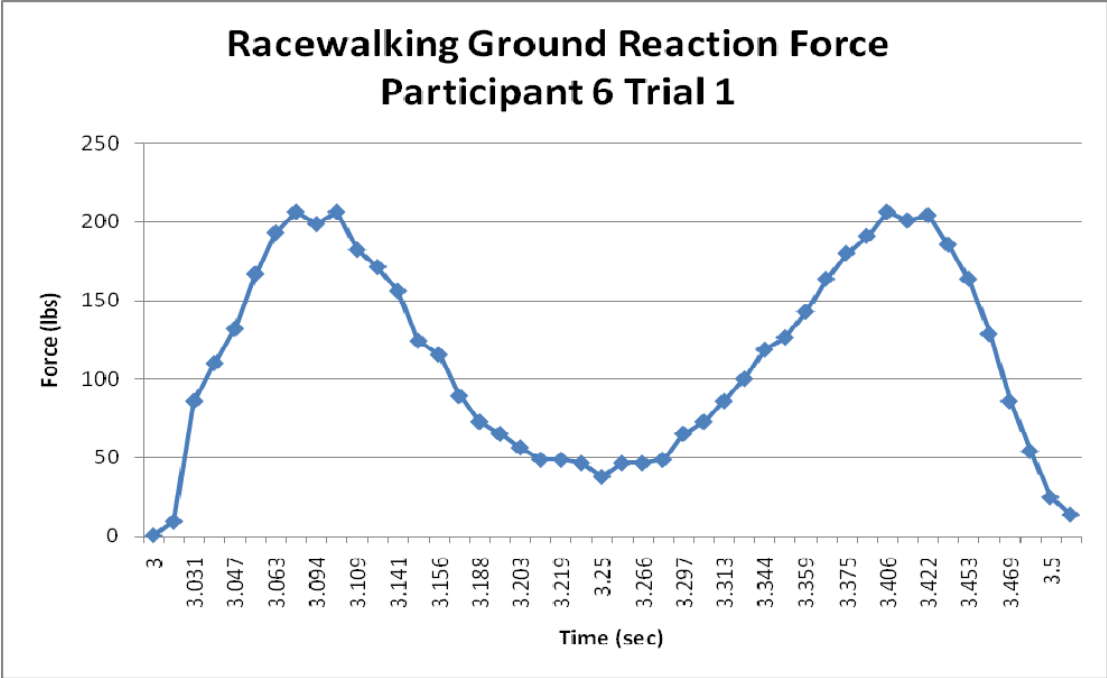

Participant 7

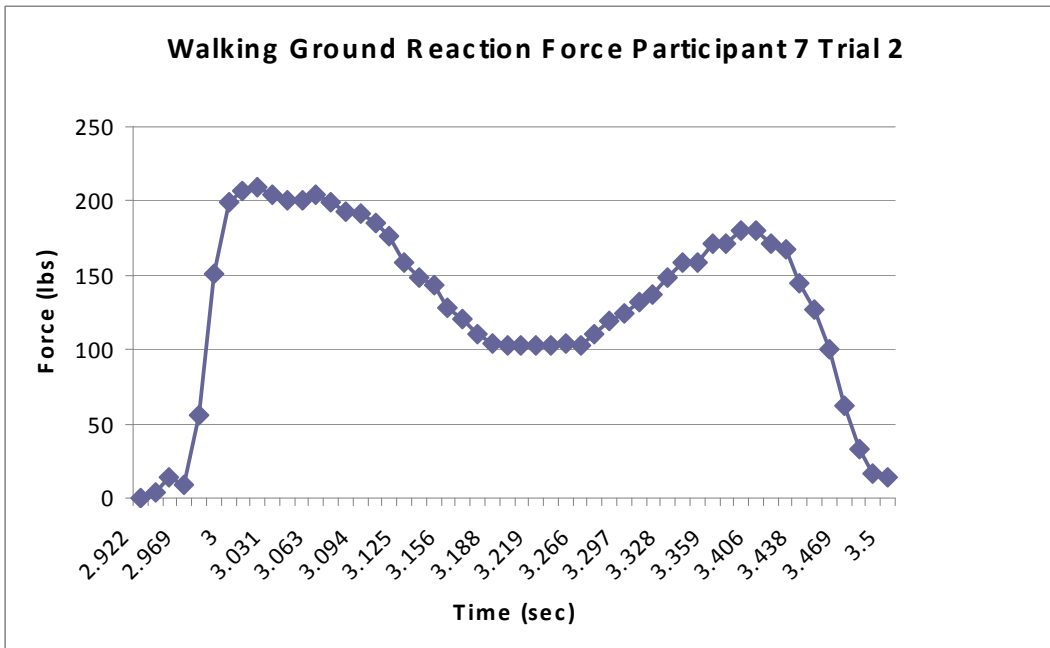
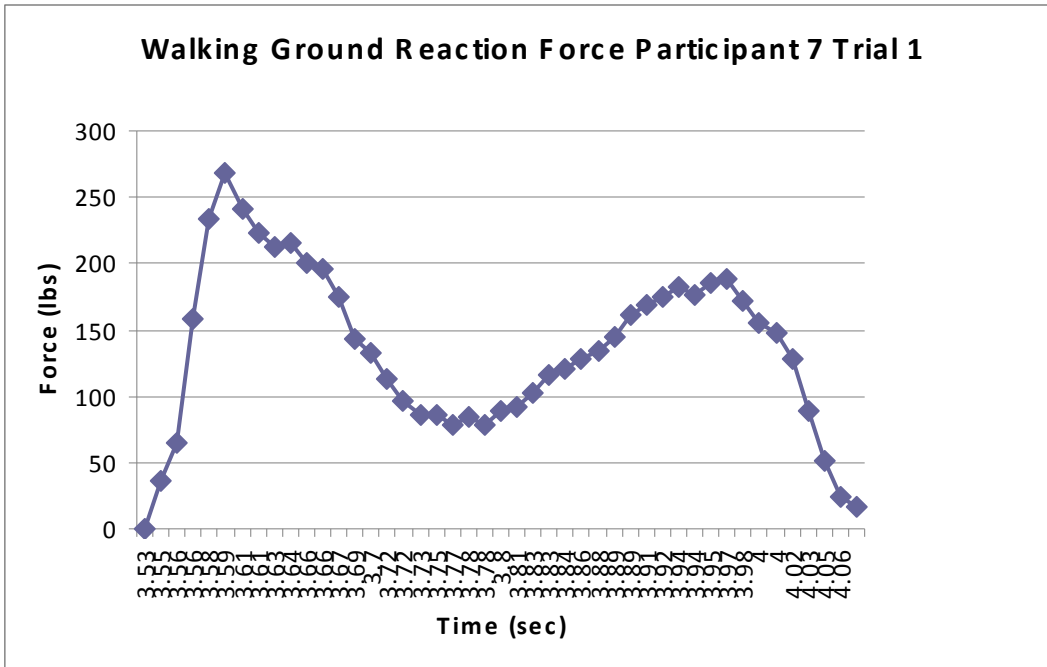

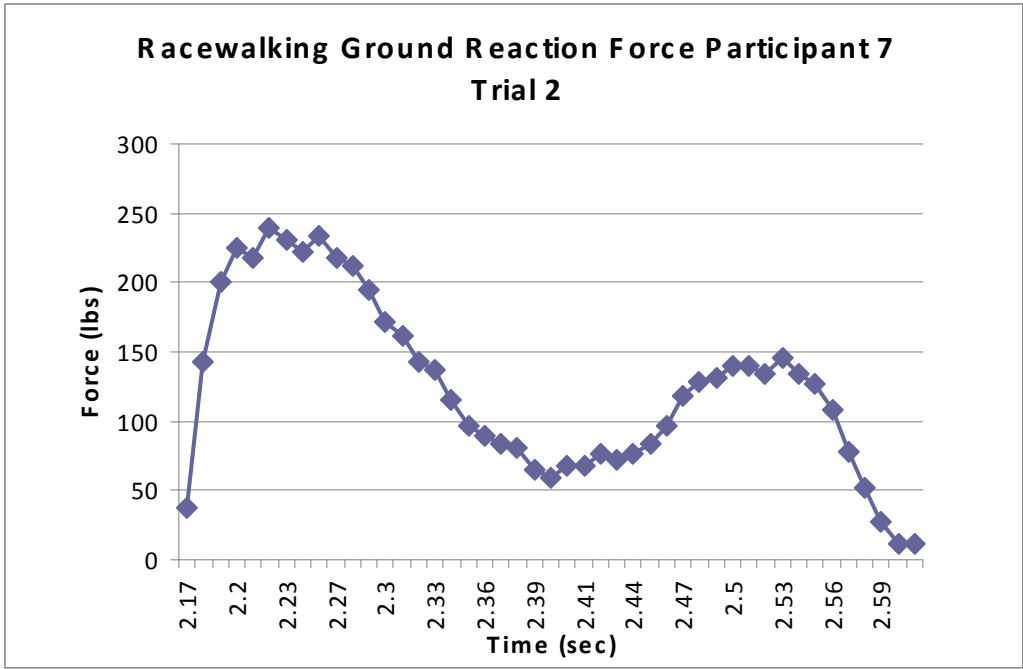
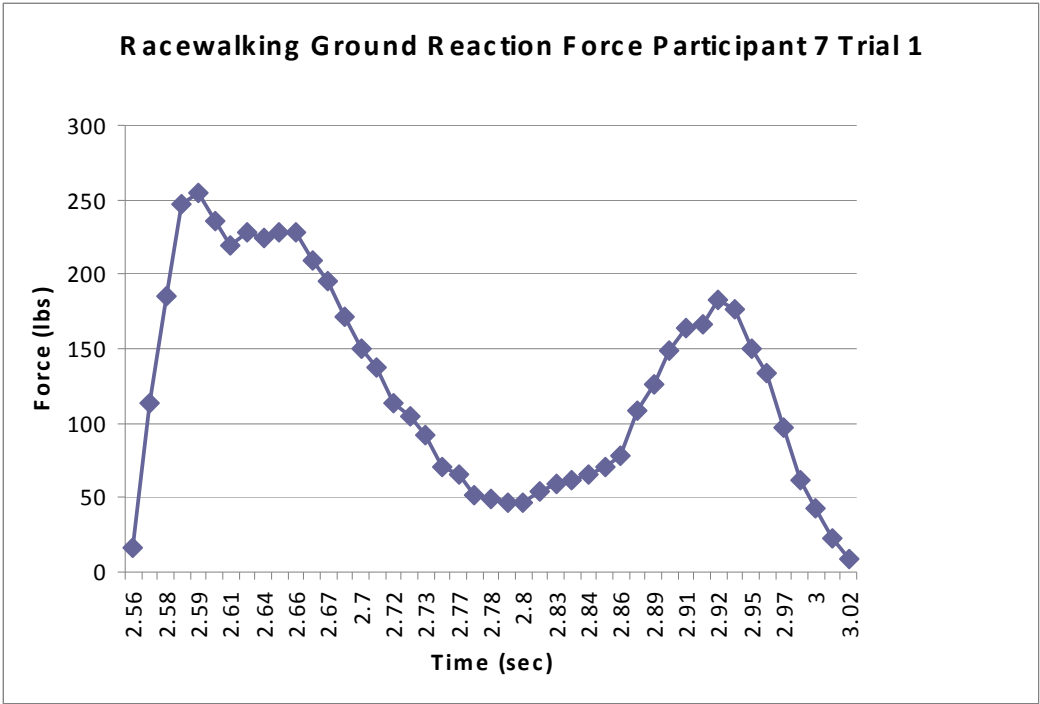

Participant 8

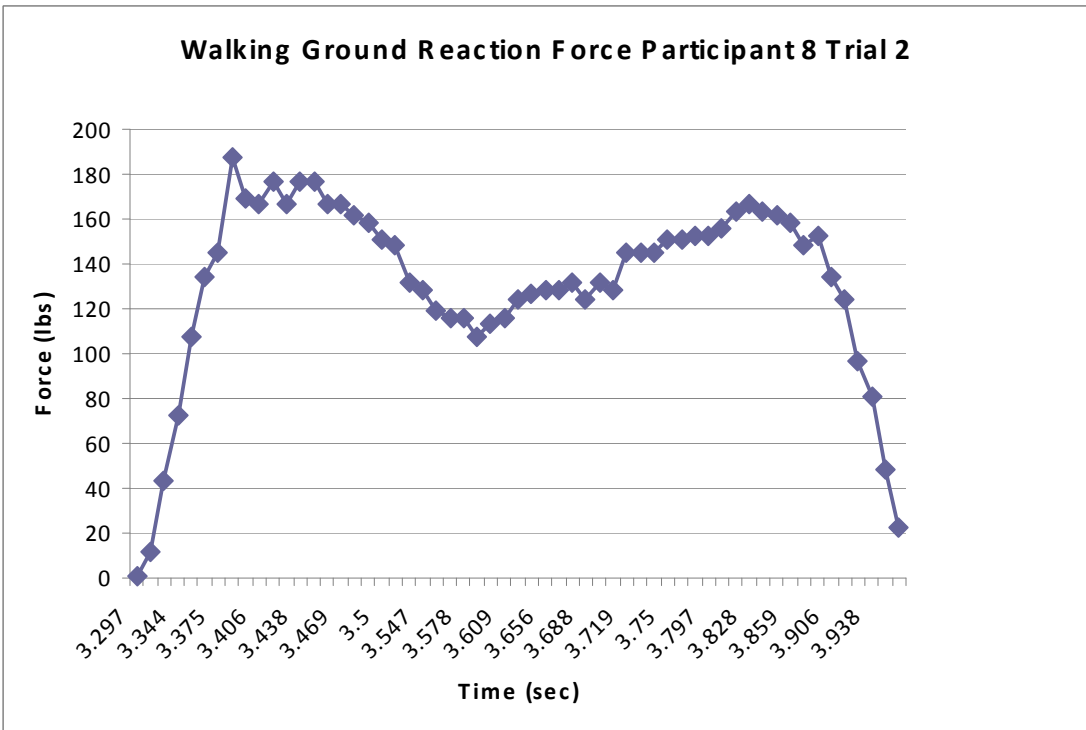
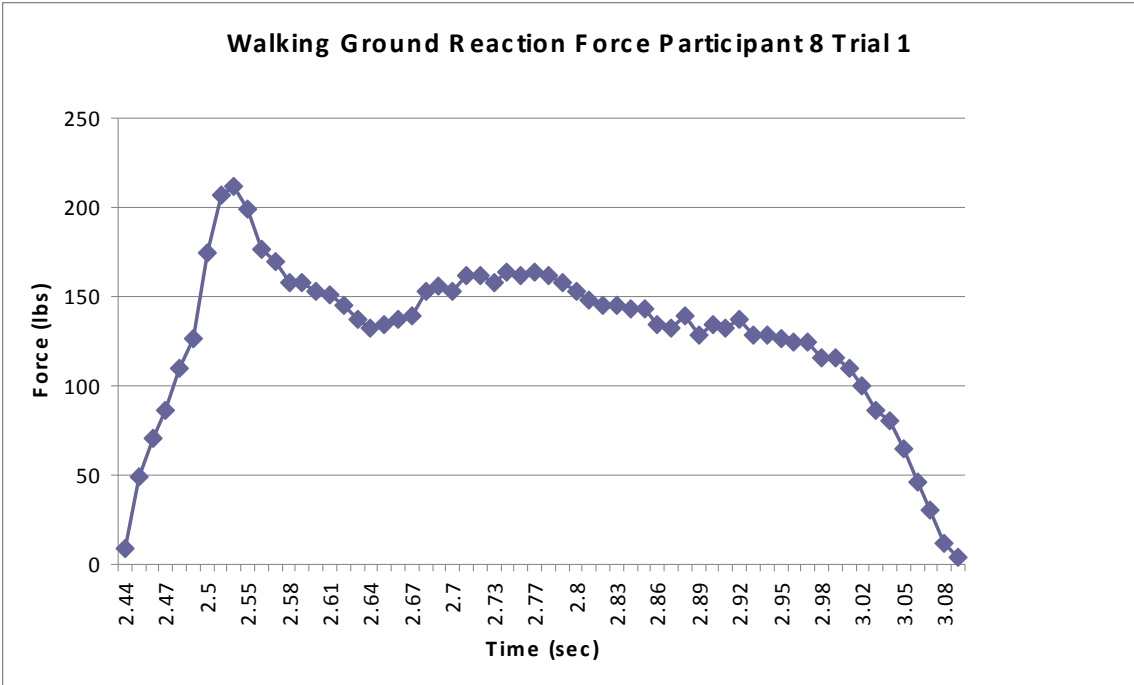

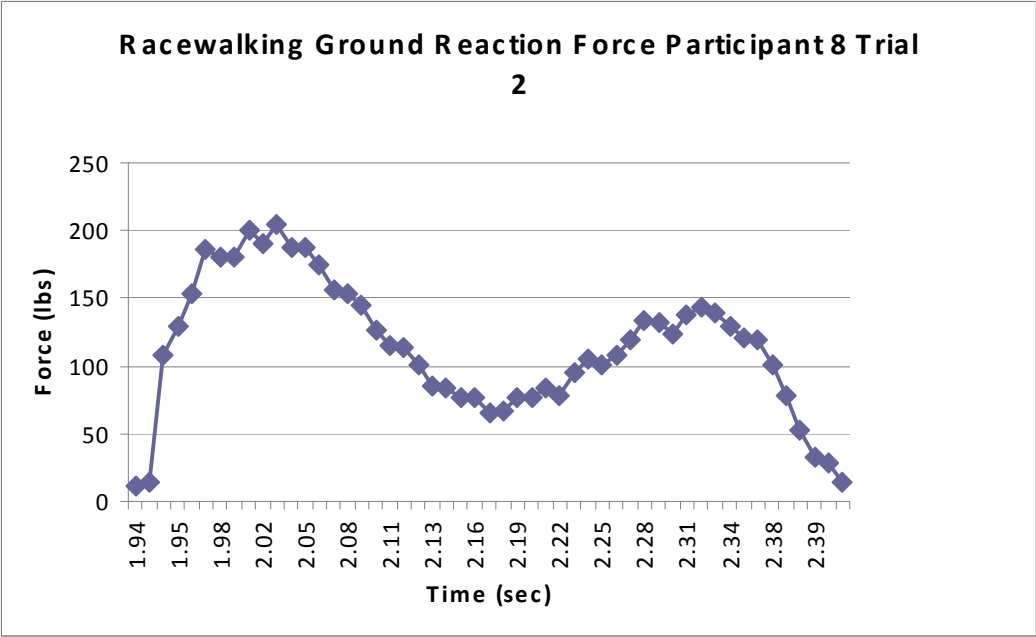
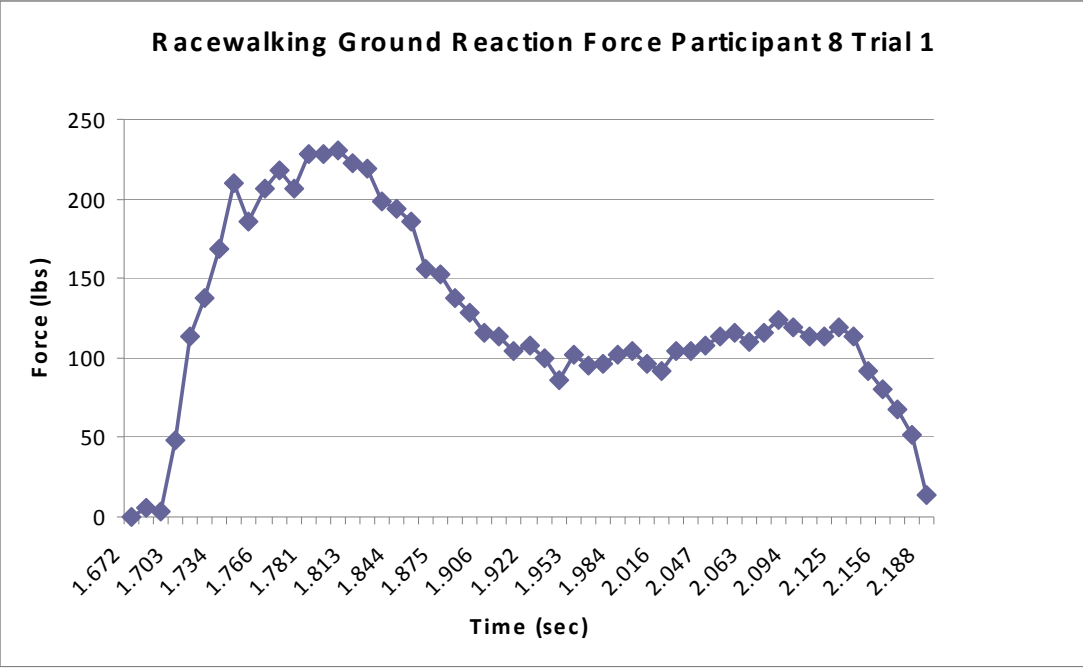

Participant 9

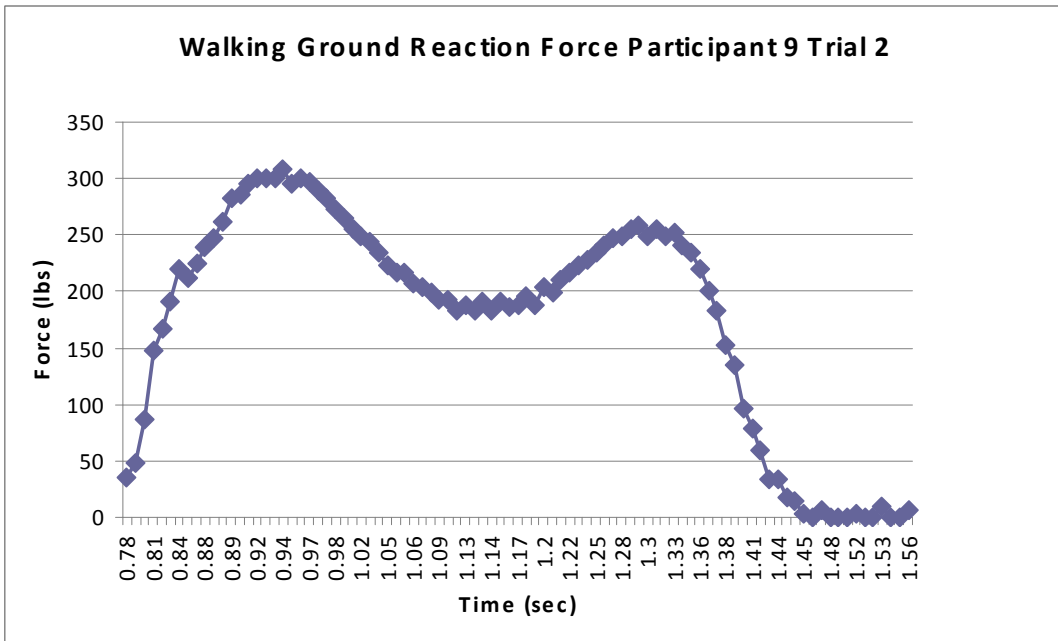
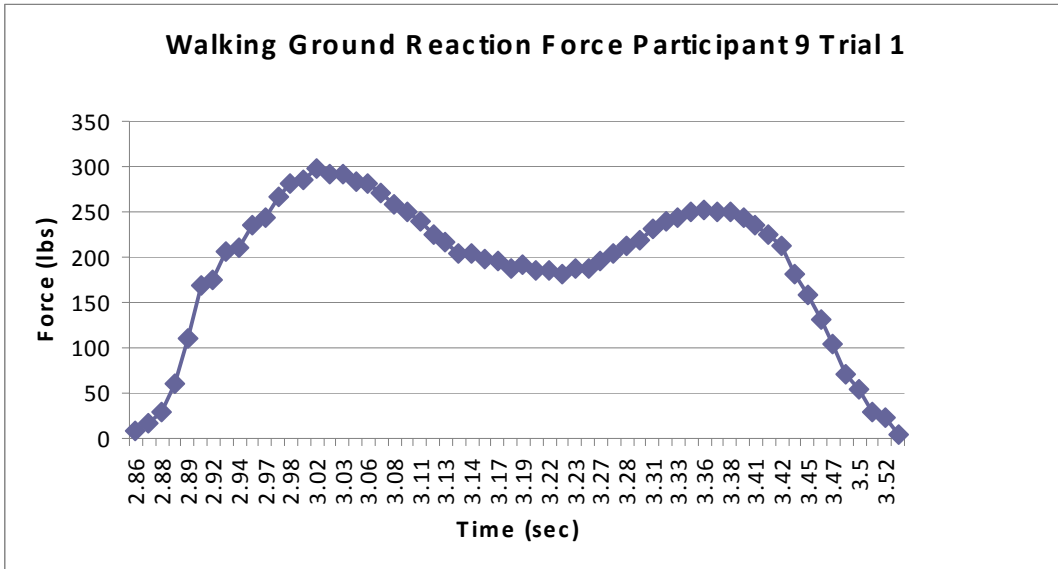

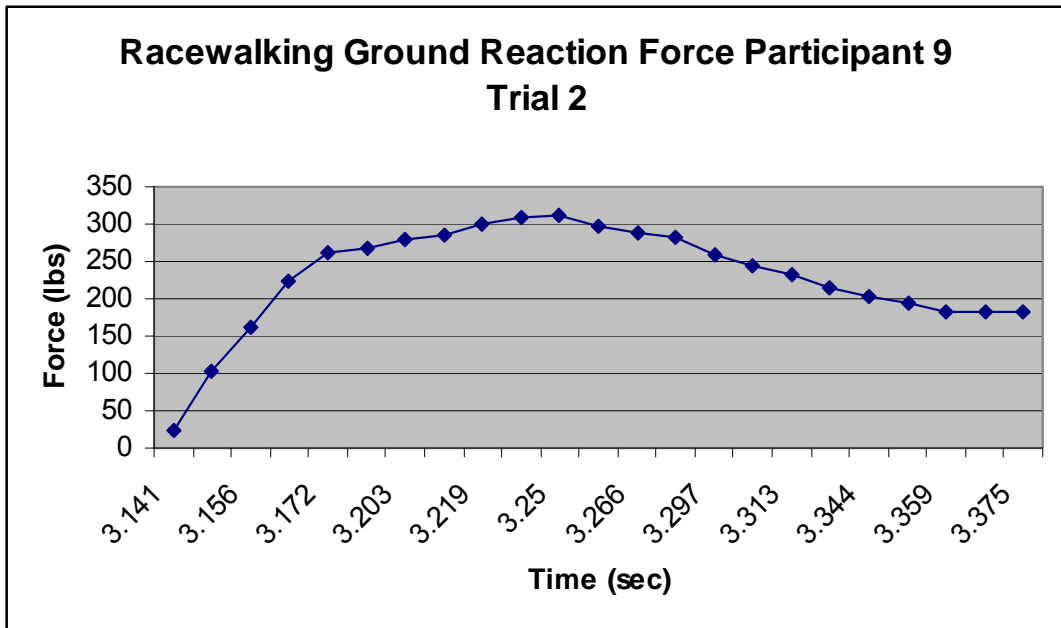
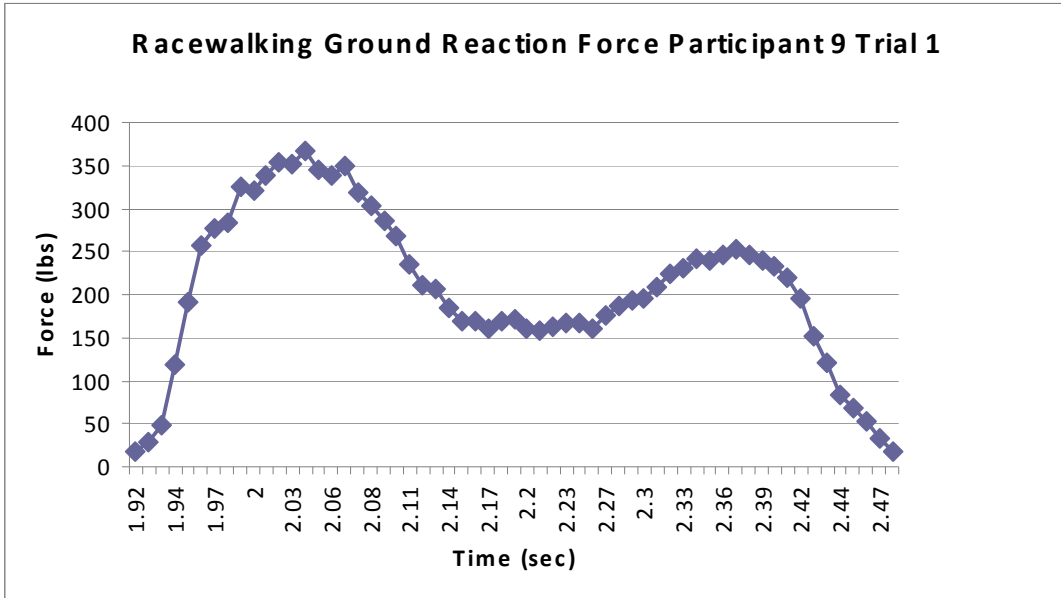

Participant 10

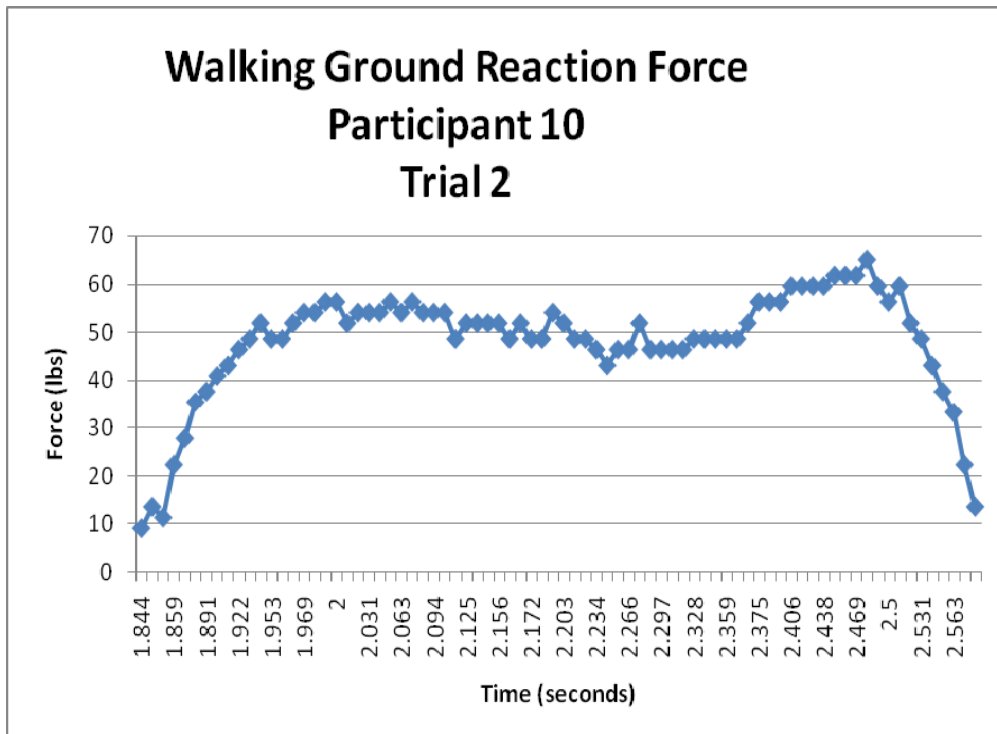
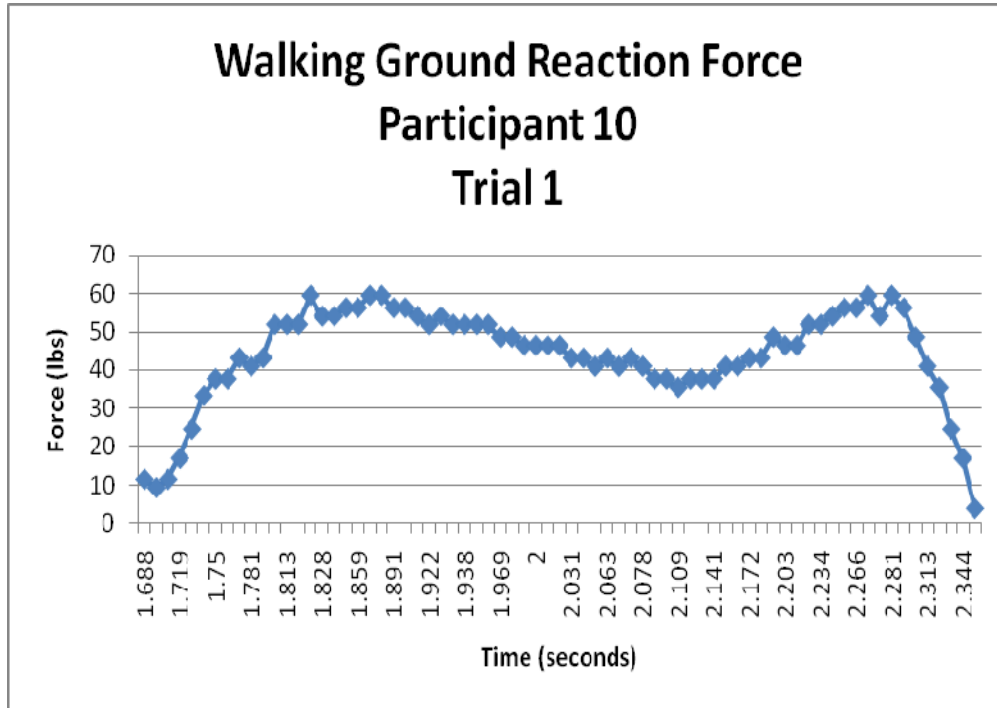

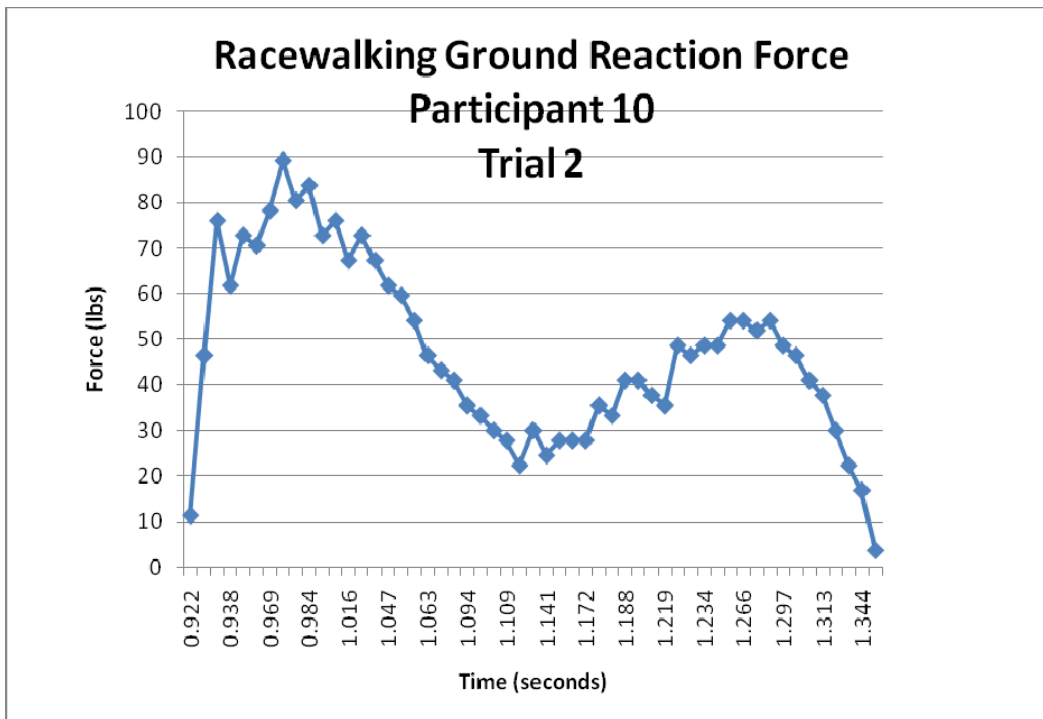
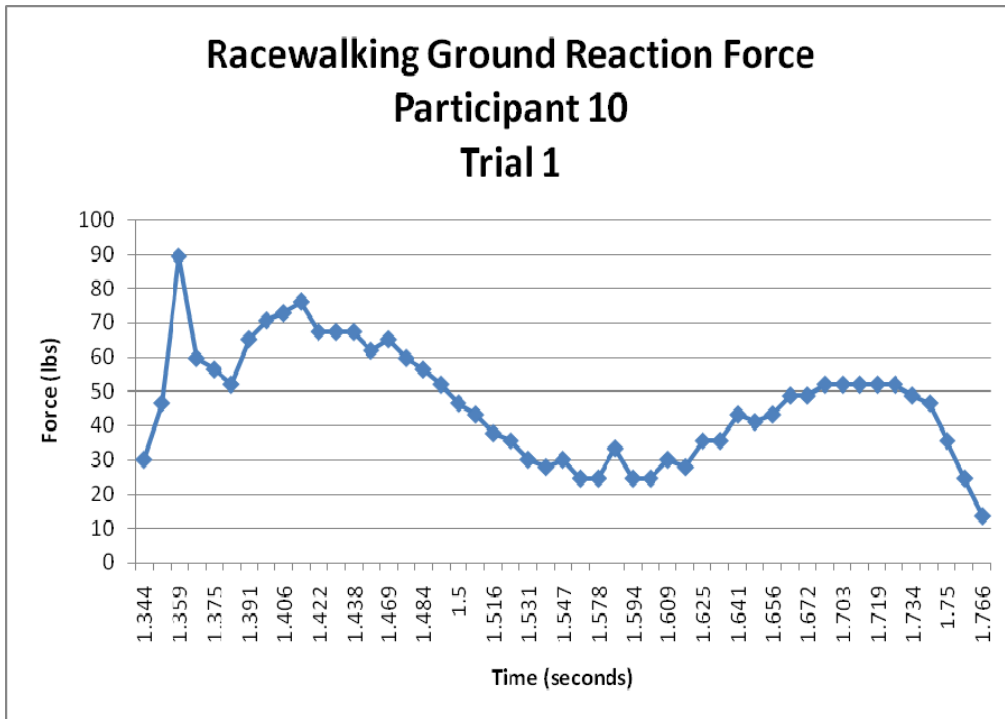

Participant 11

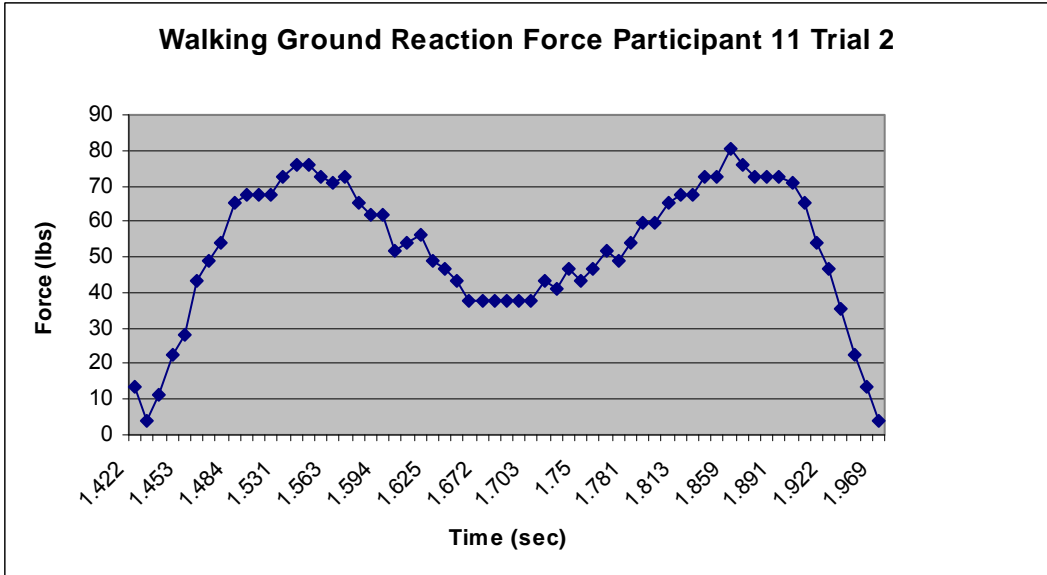
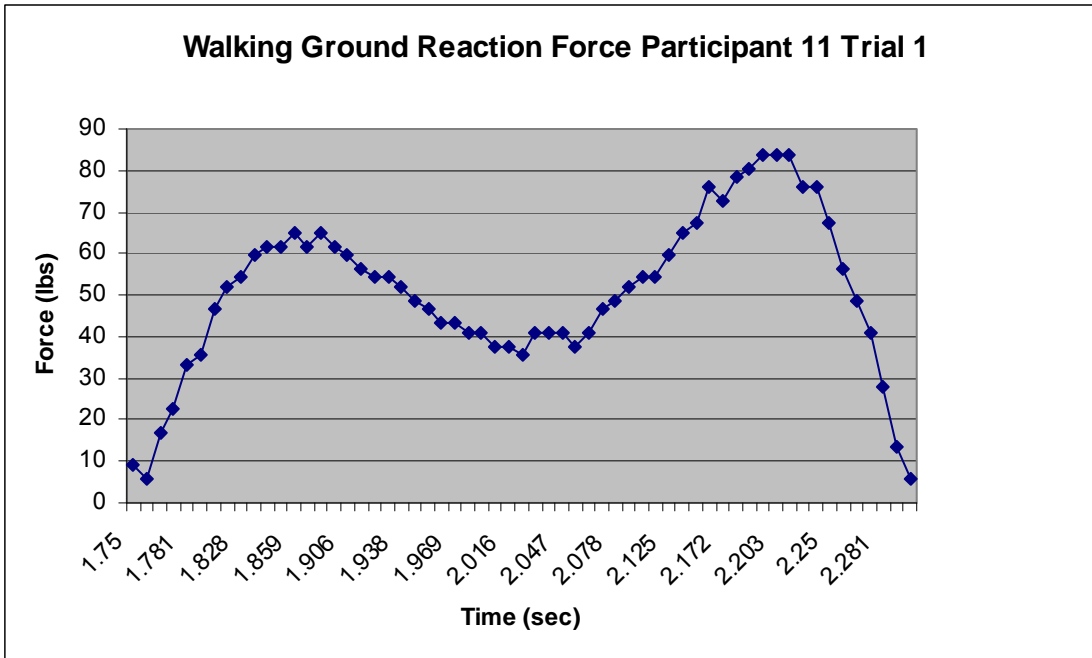

**Racewalking Ground Reaction Force
Participant 11 Trial 1**

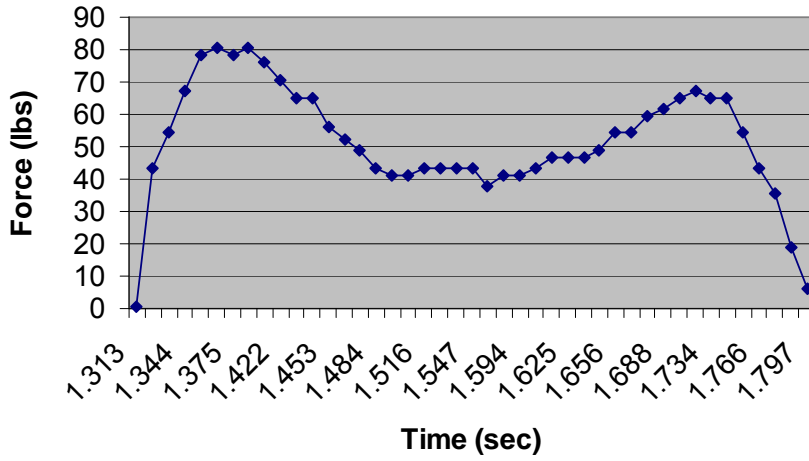

**Racewalking Ground Reaction Force Participant 11
Trial 2**

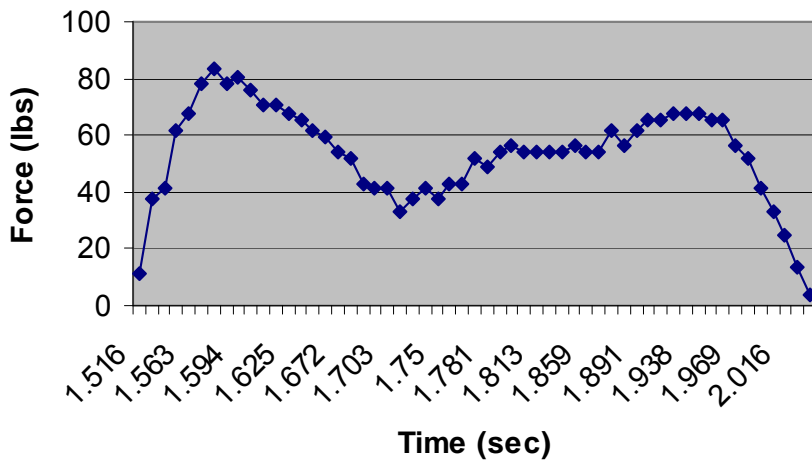

References

¹ "Human Ancestors Hall: The Laetoli Footprints." Human Evolution at the Smithsonian Institution. March 2006. <<http://anthropology.si.edu/humanorigins/ha/laetoli.htm>>.

² Kreger, C. David. "Australopithecus afarensis." ArchaeologyInfo.com. 2005. <<http://www.archaeologyinfo.com/australopithecusafarensis.htm>>.

³ Peters, Erika. The Complete Idiot's Guide to Walking for Health. n.p.: Alpha Books, 2001.

⁴ "History of Racewalking." niagarawalkers.org. January 19, 2004 2004. <<http://www.niagarawalkers.org/news/history.html>>.

⁵ "Racewalking 101: A Brief History of Racewalking." North American Racewalking Foundation. <<http://www.philsport.com/narf/c1ovehis.htm>>.

⁶ Bumgardner, Wendy. "A Brief History of Walking." About, Inc. July 28, 2007 2007. <<http://walking.about.com/library/weekly/aa061597.htm>>.

⁷ "Edward Payson Weston." <<http://www.ultrawalking.net/historia/weston.html>>.

⁸ "George Bonhag." *Wikipedia, The Free Encyclopedia*. 19 Aug 2007. Wikimedia Foundation, Inc. 18 Oct 2007 <http://en.wikipedia.org/w/index.php?title=George_Bonhag&oldid=152183115>.

⁹ "György Sztantics." *Wikipedia, The Free Encyclopedia*. 12 Sep 2007. Wikimedia Foundation, Inc. 18 Oct 2007 <http://en.wikipedia.org/w/index.php?title=Gy%C3%B6rgy_Sztantics&oldid=15729858>.

¹⁰ "International Federation of Popular Sports (IVV)." International Federation of Popular Sports (IVV). <<http://www.ivv.org/englishframe.htm>>.

¹¹ Baker, Richard. "The History of Gait Analysis before the Advent of Modern Computers." Gait & Posture 26.3 (2007): 331-342.

¹² Aristotle. Aristotle: parts of animals, movement of animals, progression of animals. Translated by Peck A. Harvard: Harvard University Press; 1968.

¹³ Westerfield, Gary A. "The Use of BIOMECHANICS IN THE JUDGING OF RACE WALKING." International Race Walk Forum. Shenzhen, China, March 23, 2007.

¹⁴ Bulat, Nicholas; Odegard, Brian. *A Biomechanical Analysis of Two Racewalking Styles*. Major Qualifying Project, Worcester Polytechnic Institute, 1997.

¹⁵ "Glossary of Telemetry, Technology & Technical Terms." Laboratory for Applied Biotelemetry & Biotechnology. June 2003. Texas A&M. 19 Dec 2007 <<http://www.tamug.edu/lab/Technology/Glossary.htm>>.

¹⁶ "Force Actions Transmitted by Joints in the Human Body" by J.P. Paul, 1976

¹⁷ Chandler, R.F, Clauser, J.T., McConville, H.M, Reynolds, H.M., Young, J.W., 1975. Investigation of Inertial Properties of the Human Body. ARML Technical Report, TR-74-137, Wright-Patterson Air Force base, OH.

¹⁸ Honeywill, Chris. Make the Grade in AS and A2 Physics. Nelson Thornes, 2002.

¹⁹ Sabatini AM, Martelloni C, Scapellato S, Cavallo F. Assessment of walking features from foot inertial sensing. *IEEE Trans Biomed Eng* 2005;52(3):486–94.

²⁰ Ledoux WR, Hillstrom HJ. Acceleration of the calcaneus at heel strike in neutrally aligned and pes planus feet. *Clin Biomech* 2001;16(7):608–13.

²¹ Wu G, Ladin Z. The study of kinematic transients in locomotion using the integrated kinematic sensor. *IEEE Trans Rehabil Eng* 1996;4(3):193–200.

²² Lafortune MA. Three-dimensional acceleration of the tibia during walking and running. *J Biomech* 1991;24(10):877–86.

Acknowledgments

The project team of Sara Gouveia and Stephanie Youkana would like to express sincere appreciation to the following people for their cooperation and assistance in this project.

Brian Savilonis

Professor of Mechanical Engineering

Worcester Polytechnic Institute

Allen Hoffman

Professor of Mechanical Engineering

Worcester Polytechnic Institute

Theo McDonald

Class of 2008

Mechanical Engineering

We would also like to thank all the participants who dedicated time to help us in our study.