

# **MODIFIED DEXTRAN POLYMERS FOR DRUG DELIVERY**

A Major Qualifying Project Report

submitted to the Faculty of

WORCESTER POLYTECHNIC INSTITUTE

in fulfillment of the requirements for the

Degree of Bachelor of Science

by

---

Ashley Bourgault

---

Matthew Regan

Date: April 27, 2006

Approved:

---

Professor Terri A. Camesano, Project Advisor

## **Acknowledgements**

We would like to take this opportunity to thank all those who advised and assisted our work throughout this project.

*Professor Terri Camesano, WPI, Project Advisor*

*Monsieur Alain Durand, LCPM, ENSIC, Site Advisor*

*Madame Michèle Léonard, LCPM, ENSIC, Site Advisor*

## **Abstract**

A collaboration between WPI and ENSIC was undertaken to investigate the properties of emulsions as a drug delivery system. The use of biocompatible amphiphilic polymers as emulsifiers for controlled drug delivery is a relatively new technology. The emulsifier acts as a barrier between phases in oil-in-water emulsions to increase stability. Oil soluble drug substances can then be encapsulated within the oil nanoparticles where the polymer surfactants help to control the drug release into a biological system over time. The goal of this project was to research the stabilization and drug release kinetics of modified dextran (DexC6), an amphiphilic polymer. The most stable emulsions were formed with a DexC6 aqueous concentration of 40g/L in a system of 40% octyldodecanol oil volume. Experiment results showed consistent drug release kinetics for DexC6, that encapsulated lidocaine is released at a much slower rate than free lidocaine. This conclusion encourages further research into drug delivery through emulsion systems.

# Table of Contents

Acknowledgements.....	i
Abstract.....	ii
Table of Contents.....	iii
Table of Figures.....	v
List of Tables.....	vi
List of Equations.....	vii
1 Introduction.....	1
2 Background.....	3
2.1 Polymers.....	3
2.1.1 Polymer Structure.....	3
2.1.2 Polysaccharides.....	5
2.1.3 Dextran.....	6
2.2 Surfactants.....	8
2.3 Micelles.....	11
2.4 Emulsions.....	13
2.4.1 Emulsion Degradation.....	15
2.4.2 Dry Emulsions.....	18
2.5 Past Research at ENSIC.....	19
2.5.1 LCPM Publications: "Surface Activity and Emulsification Properties of Hydrophobically Modified Dextrans".....	19
2.5.2 LCPM Publications: "Influence of polymeric surfactants on the properties of drug-loaded PLA nanospheres".....	20
2.5.3 LCPM Publications: "Amphiphilic derivatives of dextran: Adsorption at air/water and oil/water interfaces".....	20
2.5.4 LCPM Publications: "Amphiphilic Polysaccharides: Useful Tools for the Preparation of Nanoparticles with Controlled Surface Characteristics".....	21
2.5.5 LCPM Publications: "Neutral Polymeric Surfactants Derived from Dextran: A Study of Their Aqueous Solution Behavior".....	23
2.6 Collaboration with WPI.....	23
3 Methodology.....	26
3.1 Synthesis of Dextran C6 (DexC6).....	26
3.1.1 Dialysis Purification of the Polymer.....	26
3.1.2 Freeze Drying.....	28
3.1.3 NMR Polymer Characterization.....	30
3.2 Analysis of Lidocaine.....	30
3.2.1 Extinction Coefficient of Lidocaine.....	31
3.2.2 Solubility of Lidocaine.....	33
3.2.3 Partition Coefficients ( $K_p$ ).....	33
3.2.4 Oil Purity.....	34
3.3 Emulsions.....	35
3.3.1 Emulsion Preparation.....	35
3.3.2 Emulsification.....	36
3.3.3 Particle Sizing.....	37

3.3.4 Emulsion Stability.....	37
3.3.5 Emulsion Reconstitution.....	38
3.4 Lidocaine Encapsulation.....	39
3.5 Lidocaine Release Kinetics.....	39
3.5.1 Lidocaine Release.....	40
3.5.2 Lidocaine Release in the Presence of DexC6.....	40
3.5.3 Lidocaine Release from an Emulsion.....	41
4 Results and Discussion.....	42
4.1 Synthesis of Dextran C6 (DexC6).....	42
4.1.1 Dialysis Purification of the Polymer.....	44
4.1.2 Overcoming and Preventing Membrane Rupture.....	45
4.2 Analysis of Lidocaine.....	47
4.2.1 Extinction Coefficient of Lidocaine.....	47
4.2.2 Solubility of Lidocaine.....	48
4.2.3 Partition Coefficients ( $K_p$ ).....	49
4.3 Optimization of Emulsion Parameters.....	51
4.4 Lidocaine-Encapsulated Emulsion Stability.....	54
4.5 Lidocaine Release Kinetics.....	55
5 Conclusions and Recommendations.....	59
Bibliography.....	62
Glossary.....	64
Appendix A: Equipment and Experimental Procedure.....	67
A.1 High Performance Particle Sizer (HPPS).....	67
A.1.1 Software Set Up.....	67
A.1.2 Sample Measurements.....	69
A.2 Emulsification.....	71
A.3 Centrifugation.....	73
A.4 Freeze Drying.....	76
A.4.1 Lyophilization during Polymer Synthesis.....	77
A.5 UV Spectroscopy.....	79
A.6 Dialysis Membrane.....	81
Appendix B: Data.....	82
B.1 Emulsion Particle Size (No Lidocaine Present).....	82
B.2 Lidocaine Emulsion Particle Size.....	84
B.3 Release Kinetics: Lidocaine Only.....	85
B.4 Release Kinetics: Lidocaine and DexC6.....	86
B.5 Release Kinetics: Lidocaine-Encapsulated Emulsion.....	87
Appendix C: Sample Calculations.....	88
C.1 Sample Calculations: NMR Analysis.....	88
C.2 Sample Calculations: Lidocaine Standard Curve.....	89
C.3 Sample Calculations: Saturated Lidocaine.....	90

## Table of Figures

Figure 1: Conventional release kinetics vs. controlled release kinetics.....	2
Figure 2: Polymer Structures (Gordon, 1994) .....	3
Figure 3: Types of Linear Polymers (Faigle, 1997).....	4
Figure 4: Graft Copolymer Structure (Gordon, 1994) .....	5
Figure 5: A) Typical monosaccharide B) Illustration of monosaccharide linkage .....	6
Figure 6: Chemical structure of A) Dextran monomer B) modified DexC6 polysaccharide.....	7
Figure 7: Surfactant Molecule .....	8
Figure 8: Different Surfactant Classifications (Malmsten, 2002).....	9
Figure 9: Water Minimizing Surfactant Orientations .....	11
Figure 10: Schematic illustration of a spherical micelle (Malmsten, 2002).....	12
Figure 11: Different types of emulsions (Burguera, 2004).....	13
Figure 12: Different mechanisms of emulsion destabilization (Malmsten, 2002).....	16
Figure 13: Chemical Structure of Lidocaine.....	31
Figure 14: NMR spectrum of 20% substituted DexC <sub>6</sub> used in experimentation .....	43
Figure 15: NMR spectrum of problematic synthesis .....	44
Figure 16 : Standard curve of Lidocaine solubility .....	48
Figure 17: Partition coefficient results.....	50
Figure 18: Emulsion Particle Size Comparison.....	53
Figure 19: Lidocaine Release Kinetics Comparison.....	56
Figure 20: Correlation Function.....	70
Figure 21: High Performance Particle Sizer .....	71
Figure 22: Bioblock Scientific Sonicator.....	72
Figure 23: Centrifuge System .....	75
Figure 24: Liquid Nitrogen Bath.....	78
Figure 25: Labcono Freeze Drying System .....	78
Figure 26: UV Spectrophotometer.....	80

## List of Tables

Table 1: Average Particle Sizes of Emulsions.....	52
Table 2: Lidocaine Emulsion Particle Size.....	55
Table 3: Choosing the correct (Size measurements) adapted from Zeta Nano Series User Manual, p 4.4 .....	68

## List of Equations

Equation 1: Beer Lambert's Law .....	31
Equation 2: Partition Coefficient .....	33
Equation 3: Partition Coefficient (rearranged) .....	34
Equation 4 : Beer Lambert's Law .....	47

# 1 Introduction

As new drug substances and medical therapies are discovered it is necessary to consider their applications to human subjects. As with any medical treatment, safety and comfort of the patient is a major concern. In the realm of drug delivery this may be achieved by administering lower doses at less frequent intervals.

Traditional methods of drug delivery include intravenous and oral administration. These methods are controlled by first order rate kinetics. First order drug release is heavily dependent on time and concentration. This poses several potential dosing problems. A high concentration of drug cannot be administered due to toxicity concerns. However, only a small percentage of the drug administered actually reaches the targeted body parts and therefore several doses are required (Chaubal, 1997). These drug delivery problems are some of the pressing issues facing the pharmaceutical industry today.

An ideal drug delivery method releases the drug through zero order kinetics, resulting in a slower, more controlled drug release and a steady concentration of drug within the body. Controlled drug release helps to guard against toxicity problems because it prevents the initial spike of the drug substance that occurs with uncontrolled release (Chaubal, 1997). Slower release causes only a small amount of drug to be released over time. This means that more of the drug is absorbed by the body and less of the substance is wasted. Many drug therapies are more effective when the amount of drug remains constant in the body. Therefore, zero order kinetics is preferable because it is a safer, more efficient and more effective drug therapy. A graphical comparison of controlled release kinetics as compared with uncontrolled release kinetics is shown in Figure 1 (Chaubal, 1997).

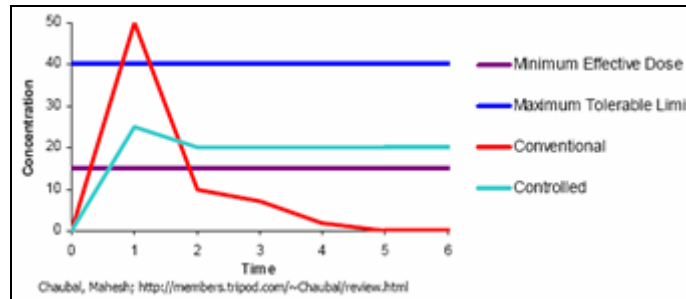

**Figure 1: Conventional release kinetics vs. controlled release kinetics**

Research has shown that zero order release kinetics can be achieved by using oil-in-water emulsion particles. In this system the drug substance is dissolved within the oil particles. These emulsions can be enhanced through the use of polymer surfactants to stabilize the emulsion particles and control the release kinetics. This type of system is beneficial because it achieves the desired release kinetics and can be used to deliver oil-soluble drugs into an aqueous system, such as the human body.

The purpose of this project was to investigate the properties of oil-in-water emulsions stabilized with a dextran polymer, DexC6. DexC6 is a natural hydrophilic sugar polymer that has been modified by addition of a hexane group to make the molecule amphiphilic. These polymers were used to stabilize the emulsions and control drug release. Parameters investigated included degree of hexane substitution, emulsion particle size, emulsion stability, oil and drug properties and drug release kinetics. Lidocaine was the model drug substance.

It was determined that octyldodecanol was the best oil choice. The most stable emulsions were formed with 40% oil volume and 40 g/L dextran in the aqueous phase. Most importantly, release of lidocaine was substantially slower when encapsulated in emulsion particles than when in free solution. The details of these finding are presenting in the following report.

## 2 Background

### 2.1 Polymers

Polymers are an important class of materials with extremely versatile physical properties. They can be natural or synthetic and include materials such as rubber, Nylon, silk, polysaccharides, plastics and DNA. Polymers first became important to the chemical industry in the 1830's when Charles Goodyear discovered the process of vulcanization to produce a stiffer and more useful form of natural rubber. The industry reached another significant milestone in the 1930's when synthetic polymers such as nylon, polystyrene, neoprene and vinyl were discovered (Gordon, 1994). Since then polymer based materials have been an important part of everyday life.

#### 2.1.1 Polymer Structure

Polymers consist of many smaller molecules, called monomers, that are chemically bonded together to form a chain. These chains can be arranged into different polymer structures. Figure 2 illustrates that the monomer chains can be linear, branched or cross-linked in a network.

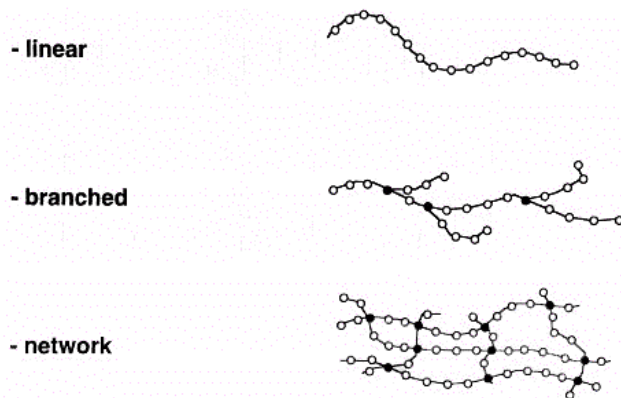
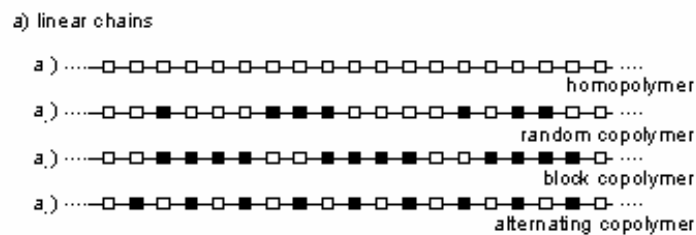

Figure 2: Polymer Structures (Gordon, 1994)

In linear chains, a polymer that consists of just one type of monomer is known as a homopolymer. A copolymer is a molecule that contains more than one type of monomer. There are several types of copolymers, including random copolymers, block copolymers, and alternating copolymers. Random copolymers have monomers that are arranged in no particular order. Block copolymers are characterized by blocks of one type of monomer followed by blocks of another monomer. Alternating copolymers rotate between monomers in a pattern (Faigle, 1997). The different monomer conformations of linear polymers are shown in Figure 3.



**Figure 3: Types of Linear Polymers (Faigle, 1997).**

The individual chains of branched polymers may contain the characteristics of linear polymers shown in Figure 3. Similarly, if the main polymer chain and its branches consist of only one monomer then it is a branched homopolymer. However, if the polymer branches are of a different monomer than the main chain, it is known as a graft copolymer, as shown in Figure 4. Polymers with a high degree of branching are known as dendrimers (Gordon, 1994).

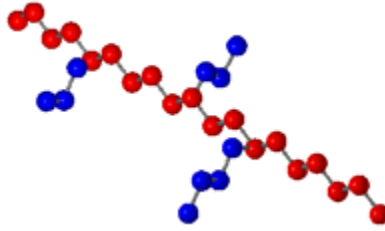
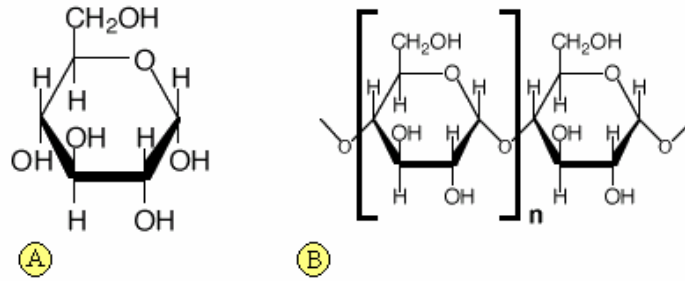

**Figure 4: Graft Copolymer Structure (Gordon, 1994)**

There are countless combinations of different structural and chemical polymer conformations. The immense variety of polymer molecules available clearly explains the wide range of physical properties exhibited by polymeric materials. It is this diversity that has made polymers such an interesting and in-demand field of research.

### **2.1.2 Polysaccharides**

Polysaccharides are a classification of polymers that are widely used in drug delivery. They are polymers whose monomers are monosaccharides. Monosaccharides are the simplest form of carbohydrates, with a chemical formula of  $(\text{CH}_2\text{O})_n$ . They are classified as ketones or aldehydes, depending on their structure and can be formed in chains or rings. The monosaccharides polymerize and are linked together through an oxygen atom to form polysaccharides, as shown in Figure 5. Polysaccharides tend to be very large and are often branched polymers.

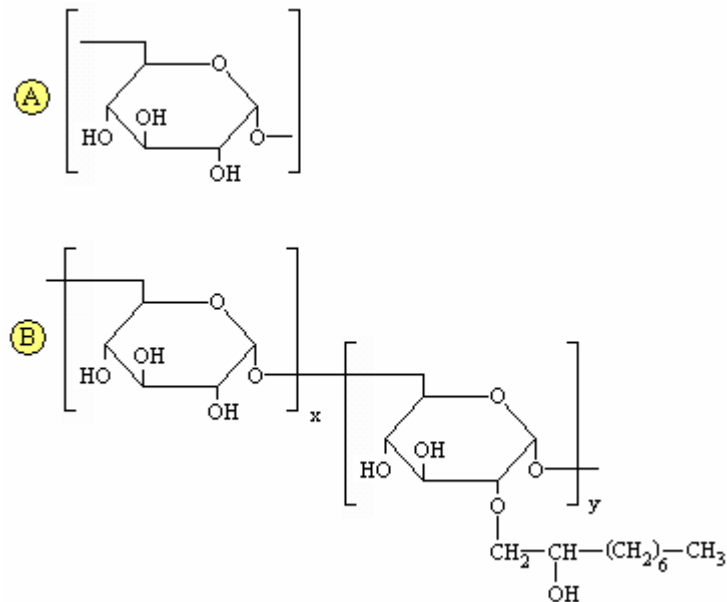

**Figure 5: A) Typical monosaccharide B) Illustration of monosaccharide linkage**

Polysaccharides are very useful in drug delivery applications because they have excellent biocompatibility and biodegradability (Dumitriu, 2001). Polysaccharides are biocompatible because they are natural polymers. Due to their chemical makeup, they are biodegradable into simple digestible sugars in the human body. These characteristics make them very useful for drug delivery applications.

### 2.1.3 Dextran

Dextran is a glucose polysaccharide. Structurally it consists of an  $\alpha$ -D-1,6-glucan linked backbone with side chains forming off the oxygen atom bonded to carbon number three. The degree of branching is approximately 5% with each side chains typically 1-2 glucose units in length. The structure of Dextran is shown in Figure 6 (Rotureau, et al., 2005).



**Figure 6: Chemical structure of A) Dextran monomer B) modified DexC6 polysaccharide**

Dextran is produced in a laboratory by the bacterium *Leuconostoc mesenteroids* B512F during fermentation of sucrose from sugar beets (Amersham). The Dextran polymer is then divided into fractions based on average molecular weight. Dextran polymers range in molecular weight from 1,000-200,000 daltons. Typical fraction notation is the molecular weight divided by 1,000, therefore a Dextran fraction with an average molecular weight of 40,000 would be denoted Dextran 40.

Dextrans have several properties that make them good candidates for drug delivery applications. They are readily soluble in water and are neutrally charged. In a dry powder form they are stable for more than five years. However their most significant asset is their biocompatibility. Dextran may be ingested orally and is quickly digested as evidenced by an increase in blood sugar. It has been used intravenously as a blood plasma extender since the Korean War. Blood plasma extenders can help to temporarily keep trauma patients alive who have lost a lot of blood (Chemical Heritage Foundation).

Dextran is also biodegradable and its byproducts are readily absorbed into the natural environment.

Natural Dextran can be easily modified by substitution with functional groups to manipulate its physical properties. This study will focus on Dextran 40 reacted with epoxyoctane to form DexC6, or Dextran substituted with hexane chains, as shown in Figure 6. The hexane groups are soluble in organic materials, creating an amphiphilic polymer that gives DexC6 its surfactant properties.

## 2.2 Surfactants

Surfactants are a special type of molecule, generally of low to moderate molecular weight, which consist of a hydrophobic part and a hydrophilic part. The hydrophobic part of the molecule, known as the tail, is soluble in oils and organic materials, but is more or less insoluble in water. Conversely, the hydrophilic portion of the molecule, or polar headgroup, is soluble in water and relatively insoluble in organic material (Malmsten, 2002). The anatomy of a surfactant molecule is shown in Figure 7.

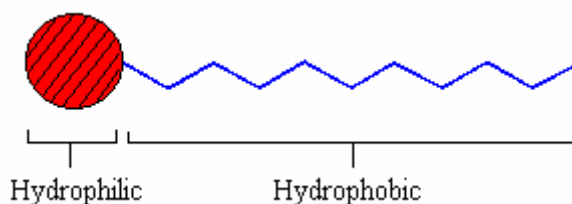

**Figure 7: Surfactant Molecule**

The hydrophobic chains of surfactant molecules are generally similar from one molecule to another (Hargreaves, 2003). However, there is significant variety in the

nature of the hydrophilic portions, therefore surfactants are classified according to their headgroups. Figure 8 shows that there are four classifications: anionic, cationic, nonionic and zwitterionic (amphoter) surfactants.

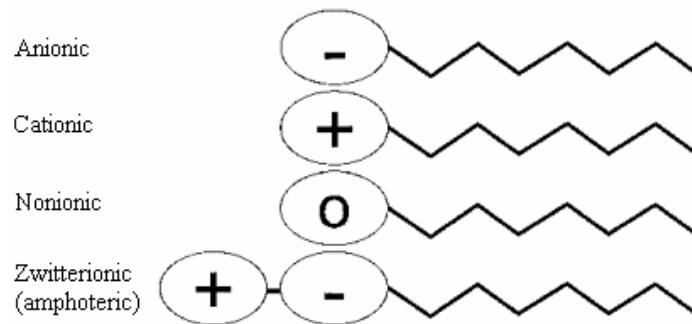

**Figure 8: Different Surfactant Classifications (Malmsten, 2002)**

Anionic surfactants are the largest of the four groups. They are characterized by their negatively charged polar headgroup. Due to their highly electronegative atoms they are particularly sensitive to salts and will display a decrease in surfactant properties in the presence of salts (Malmsten, 2002). Anionic surfactants are most frequently used in soaps and cleaning agents due to their pronounced detergent properties, however, they have also found significant use in drug delivery applications.

Cationic surfactants consist of positively charged headgroups, frequently obtaining their charge from amines. Similar to anionic surfactants, they are also sensitive to salts. They are often irritating and potentially toxic in biological systems. Therefore, they have limited use in drug delivery applications, with the exception of antibacterial functions (Malmsten, 2002).

Nonionic surfactants are molecules with uncharged polar headgroups. Because they have no charge they are much less sensitive to salts, however, display some temperature sensitivity. Micelle formation (to be discussed in Background section 2.3) occurs at lower surfactant concentration. Overall, nonionic surfactants are less irritating than charged solvents and therefore are the most frequently used in drug delivery systems (Malmsten, 2002).

The final class of surfactants, zwitterionic or amphoteric surfactants, has a polar headgroup with both positively and negatively charged ions. Depending on pH, a zwitterionic surfactant may behave as a cation or anion (Hargreaves, 2003). They are less common, however, they are used in personal care products because they are mild with a low irritancy.

Regardless of the headgroup classification, their common basic structure causes all surfactants to behave similarly in solution. Their amphiphilic structure prevents surfactants from dissolving normally in aqueous solution. In fact, if the hydrophobic tail is very prominent, the surfactant may not dissolve at all. However, if the molecule has enough polar character to be water soluble the surfactant molecules display interesting behavior in solution. This is due to the fact that contact between water and the hydrophobic surfactant tails is thermodynamically less favorable than the intermolecular contact between surfactant tails (Malmsten, 2002).

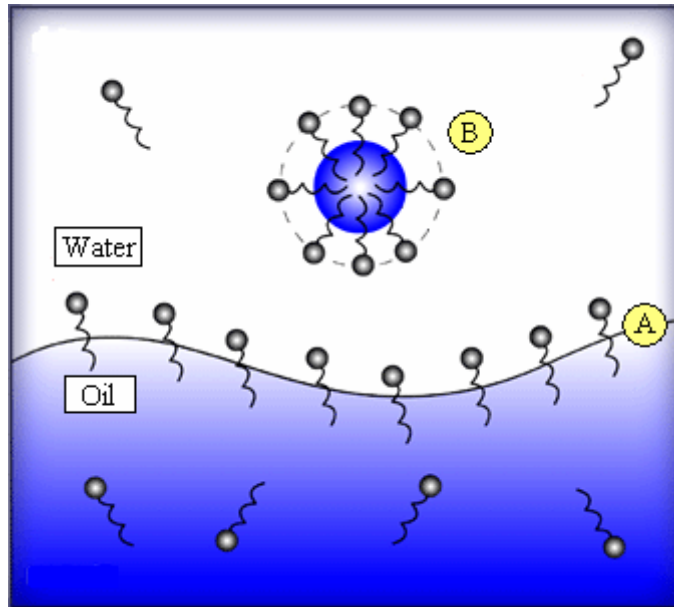

**Figure 9: Water Minimizing Surfactant Orientations**

**A) adsorption at the oil-water interface B) micelle formation**

Similarly to an oil and water mixture, the forces between similar molecules (water-water or oil-oil) are stronger than the forces between oil and water molecules (Hargreaves, 2003). This causes the surfactant molecules to orientate themselves to minimize contact between their hydrophobic tails and water molecules. They do this by adsorbing at interfaces, for example in emulsions, or by associations between surfactant molecules to form self-assembly structures such as micelles. Figure 9 shows examples of water minimizing surfactant orientations. The effect of micelles will be further discussed in the following section.

## **2.3 Micelles**

The formation of micelles is a special characteristic of surfactant molecules. A micelle is an aggregate of surfactant molecules, usually spherical in shape, but other

geometric shapes are possible, such as rods, packed rods and parallel layers (Wikipedia). A typical spherical micelle is shown in Figure 10. In an aqueous solution micelle surfactant molecules orientate themselves with hydrophobic tails inward so as to exclude water molecules. This arranges the sphere so that the hydrophilic polar head groups are facing outwards, readily interacting with water molecules. This conformation is energetically more favorable because it allows the electrostatic interactions of ionic or polar molecules.

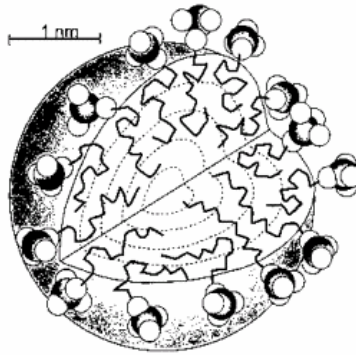

**Figure 10: Schematic illustration of a spherical micelle (Malmsten, 2002).**

Micelles are a result of the amphiphilic nature of surfactants. Their duality causes them to have limited solubility in water. At concentrations above their maximum solubility, surfactant molecules associate to form aggregates such as micelles (Hargreaves, 2003). This concentration is known as the critical micelle concentration (CMC), which is different for each surfactant. This is the concentration at which micelles are first formed and also can be found by various physical-chemical properties such as osmotic pressure, surface tension, turbidity, electrical conductance, spectral behaviour, and others (Burger, et al., 2004). The formation of micelles in solution is an important

characteristic of surfactant molecules and must be taken into consideration during emulsion preparation.

## 2.4 Emulsions

An emulsion is a mixture of two immiscible liquids, where one phase is dispersed within the other in the form of droplets. The droplets are known as the dispersed phase and the bulk liquid is known as the continuous phase. There are two kinds of emulsions that are common in drug delivery applications, water in oil (W/O) and oil in water (O/W). W/O emulsions are frequently used for sustained release of drug substances, such as steroids or vaccines, through intramuscular injection. O/W emulsions are most commonly used for intravenous injections (Stevens, 2003). “Double emulsions” of oil-water-oil (O/W/O) and water-oil-water (W/O/W) also exist, but are more complex and less common. The major emulsion types are shown in Figure 11

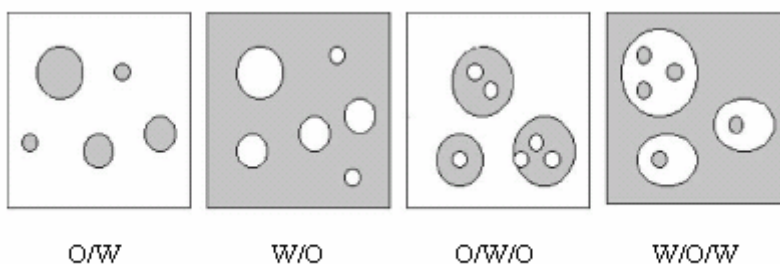

**Figure 11: Different types of emulsions (Burguera, 2004)**

Prior to mixing the two liquids will remain as two separate phases with the substance of lower density layered on top of the substance of higher density. An emulsion is thermodynamically unstable and therefore will not form spontaneously,

energy must be added. Energy may be added in the form of vigorous shaking or sonication, which uses sound waves to agitate the mixture. The formation of an emulsion system is a complex process which involves the generation and stabilization of new interfaces (Malmsten, 2002). These new interfaces exist in the barrier between droplets of the dispersed phase and the bulk continuous phase. The additional interface area often causes emulsions to appear opaque. Increasing interface area also increases the total amount of interfacial tension in the system, therefore making it less stable and explaining the need for excess energy.

For drug delivery purposes emulsion components must be chemically and physically stable, sterilizable, biologically compatible and reasonably priced. The droplets are typically between 200 and 600 nm in diameter with greater than 90% of the particles below 1000 nm (Stevens, 2003). Based on these criteria emulsions stabilized with polysaccharide surfactants are very useful because polysaccharides are natural sugar molecules and are biocompatible with the human anatomy. Emulsions are important in drug delivery because they provide safer administration of water insoluble drugs. A drug substance can be dissolved in the dispersed oil phase if it is insoluble in the continuous aqueous phase. This is a useful method for getting oil-soluble drugs into the aqueous environment of the human body without the use of hazardous organic solvents.

The drawback of using emulsions in drug delivery is that they are naturally unstable. If they are not stabilized the droplets will coalesce into two distinct phases. However, if the destabilization can be slowed down then they can certainly be very useful in drug delivery applications. Their destabilization can be significantly slowed through the use of surfactants. Amphiphilic surfactants are able to arrange themselves so that

their hydrophobic tails are anchored to the oil phase and their hydrophilic heads are exposed to the aqueous phase. They then act as a stabilizing barrier between the two phases. This helps to lower the interfacial tension and therefore slow destabilization. It may also help to form smaller emulsion particles (Malmsten, 2002). Once these particles have been stabilized they are much more useful. In order to create emulsions useful for drug delivery purposes, it is important to study their stability and the mechanisms by which they destabilize.

### **2.4.1 Emulsion Degradation**

As previously stated, emulsions are thermodynamically unstable. Figure 12 shows that there are four main mechanisms by which emulsions destabilize: creaming, flocculation, coalescence and Ostwald ripening. Each type occurs gradually over time and depends on different emulsion characteristics. Knowledge of the destabilization mechanism helps one to manipulate the emulsion characteristics, therefore slowing the rate degradation and producing a more stable emulsion.

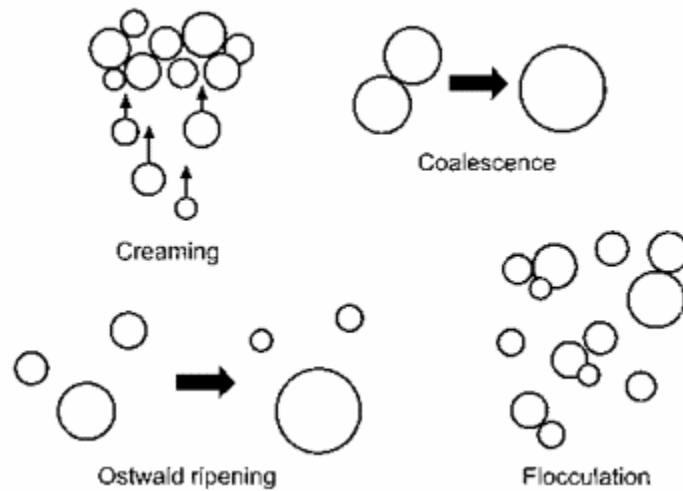

**Figure 12: Different mechanisms of emulsion destabilization (Malmsten, 2002).**

Creaming is a form of emulsion destabilization based on gravity and density. Creaming, occurs when there is a significant density difference between the dispersed droplets and the continuous phase. If the density of the droplets is lighter than that of the continuous phase, then the droplets float to the top and form a layer. Sedimenting is the opposite of creaming and occurs when the droplets are denser than the continuous phase and sink to the bottom. Creaming is also dependent on droplet size, with larger droplets creaming (or sedimenting) faster than smaller ones. The rate of creaming can be slowed by decreasing droplet size or by increasing the viscosity of the continuous phase (Malmsten, 2002).

Flocculation occurs when emulsion droplets clump together into loose formations called flocs, but do not join to form a larger droplet. This is also known as aggregation. The predominant cause of this phenomenon is inter-particle interactions, especially electrostatic interactions. This is more frequent in high concentration emulsions because when there are more particles there is a higher probability of collision and interaction.

The electrostatic interaction can be decreased by the presence of a low salt concentration in the continuous phase to balance the charged particles. However, increasing salt concentration will increase electrostatic repulsion and increase the rate of flocculation until the salt concentration reaches a point where it is high enough to re-stabilize the particles and the rate of flocculation decreases (Malmsten, 2002). Therefore, to avoid emulsion destabilization by flocculation the salt content of the continuous phase should be monitored.

Coalescence occurs when two emulsion droplets approach each other and the continuous phase fluid between them drains out. This causes the interfacial film between them to become thinner. If the film ruptures then the two droplets combine to become one larger droplet. This change is irreversible. The presence of stabilizing surfactants protects against coalescence because surfactants provide a steric barrier and serve to lower interfacial tension between emulsion droplets (Malmsten, 2002). If there is not enough surfactant present in the continuous phase or the droplet size is so small that there is not enough surfactant to sufficiently coat the emulsion droplets coalescence will occur. Therefore, the best way to prevent coalescence is to ensure there is sufficient amount of surfactant present.

The final and most complex emulsion destabilization mechanism is Ostwald ripening. This occurs when large emulsion droplets grow larger and small emulsion droplets shrink and eventually disappear. This is related to the pressure within the emulsion droplets. The pressure within an emulsion droplet is larger when the surface curvature is larger, or when the droplets are small. This causes the dispersed phase to have a higher solubility outside a small droplet than outside a large droplet. Therefore,

the material in small droplets can dissolve in and diffuse through the continuous phase until it comes out of solution and joins the material in a larger droplet. Eventually the small droplets disappear; meanwhile the large droplets have gained material and grown larger. This is dependent upon the solubility of the dispersed phase in the continuous phase, the higher the solubility, the faster the emulsion degradation (Malmsten, 2002).

### **2.4.2 Dry Emulsions**

Solid substances are generally much more stable than those in liquid form. For this reason it is sometimes desirable to dry drug-encapsulated emulsions to prolong shelf life and preserve stability. The dried particles can later be used for intravenous injection after reconstitution into liquid form by the addition of solvent. Emulsions may also be dried to form tablets for oral administration pathways. This is done through lyophilization or freeze-drying. During lyophilization the sample is frozen with liquid nitrogen and then the solvents are allowed to sublime under vacuum conditions. The extreme conditions produced by the lyophilization process can affect the physical and chemical properties of the drug, therefore, care must be taken to preserve the material of interest. During drying, the solutes are concentrated which may result in particle aggregation. Compounds such as carbohydrates and polyalcohols are sometimes used as protectants to buffer the emulsion particles. Polysaccharide surfactants such as Dextran are natural carbohydrates and therefore act as protectants in dry emulsions (Malmsten, 2002). Dry emulsions are still a fairly new technology and there is still much research to be done.

## **2.5 Past Research at ENSIC**

The Laboratoire de Chimie Physique Macromoléculaire (LCPM) at ENSIC has been researching polymeric surfactants for many years now. They aim to develop polymer stabilized, oil in water emulsions for use in drug delivery systems. Much of their study in this area has been focused on Dextran, a natural polysaccharide. Natural polysaccharides are good candidates for this application because they are water soluble, have low toxicity and low biological interaction (Rouzes, et al., 2002).

### **2.5.1 LCPM Publications: "Surface Activity and Emulsification**

#### **Properties of Hydrophobically Modified Dextrans"**

In order to enhance the surfactant properties of natural Dextran the polymer was modified with hydrophobic groups to obtain an ionically neutral, amphiphilic molecule. In 2001 LCPM investigated the properties of Dextran substituted with phenoxy aromatic rings, denoted DexP. The DexP formed a protective layer around the oil droplets. As compared with unmodified Dextran, DexP produced smaller emulsion droplets with a thinner polymer layer coating the droplet. This indicated that the DexP layer was more densely packed than the unmodified Dextran layer, which was attributed to the presence of hydrophobic anchoring groups. The study also found that as the DexP concentration was increased, the aqueous solution viscosity was lowered, the interface layer became more closely packed due to a more compact formation, and both the surface tension and interfacial tension decreased. The study concluded that oil in water emulsions stabilized with hydrophobically modified Dextran was a promising development in drug delivery systems (Rouzes, et al., 2002).

## **2.5.2 LCPM Publications: "Influence of polymeric surfactants on the properties of drug-loaded PLA nanospheres"**

The following year LCPM continued to investigate modified Dextran and optimize their properties. The study was expanded to include alkyl modified Dextran (DexC4 and DexC10) as well as DexP. It was determined that Dextran polymers with a low degree of substitution did not form stable emulsion particles. However, polymers with a higher degree of substitution formed stable emulsion particles due to the presence of hydrophobic anchoring groups and lowered surface tension. LCPM also researched the formation of drug-loaded nanospheres through emulsions stabilized with modified Dextran. The polymer was placed in an aqueous solution while the drug substance (lidocaine) was dissolved in oil. By studying a series of emulsions it was concluded that DexP cannot be used to encapsulate lidocaine. This was explained by the interaction between the drug substance and the phenoxy aromatic ring. This reduced the surfactant properties of the modified Dextran and prevented the formation of stable emulsion particles. However, successful drug-loaded nanospheres were formed with alkyl Dextran. The DexC coated particles exhibited similar diffusion-controlled release of lidocaine as uncoated particles, therefore indicating that polymer coating does not significantly alter drug release kinetics (Rouzes, et al., 2003).

## **2.5.3 LCPM Publications: "Amphiphilic derivatives of dextran: Adsorption at air/water and oil/water interfaces"**

In 2003 research was expanded to include substitution with ionic groups as well as hydrophobic groups. These polymers were denoted  $\text{DexP}_{\tau}\text{S}_s$ , where  $\tau$  indicates the

degree of hydrophobicity and  $s$  indicates the degree of ionic substitution. This was done to increase the degree of substitution while maintaining polymer solubility. Previously, the upper limit of the degree of substitution was approximately 20%, which was limited by the ability of the polymer to remain soluble in water. By introducing ionic substitutions as well as hydrophobic ones the overall degree of substitution could be much larger. Previous research has shown that the larger the degree of substitution, the larger the decrease in surface tension. This trend was examined by experimenting with polymers with a range of hydrophobicities and charge densities. Modifying Dextran chains with ionic groups had a significant effect on the adsorption kinetics. It was observed that if hydrophobicity is maintained, increasing the ionic content of the polymer slows the time dependence of polymer adsorption. This is explained by increasing electrostatic interactions and repulsions. Conversely, maintaining the ionic content and increasing the hydrophobicity of the polymer results in faster kinetics due to faster dynamic surface tension. In this case the hydrophobic interactions were predominant and the presence of ionic groups served to maintain solubility. Therefore, by significantly increasing the hydrophobic degree of substitution and using ionic groups to maintain solubility, adsorption kinetics and dynamic surface tension are much faster (Rotureau, et al., 2004).

#### **2.5.4 LCPM Publications: "Amphiphilic Polysaccharides: Useful Tools for the Preparation of Nanoparticles with Controlled Surface Characteristics"**

The 2004 LCPM publication focused on the kinetics of oil in water emulsion stabilization and the size of the resulting droplets. Kinetics was studied by observing the

change in interfacial tension over time. The study determined equilibrium of droplet formation was determined by the diffusion of the polymer. The limiting step was the diffusion into the already-adsorbed layer of macromolecules rather than diffusion through the bulk solution. The time required for equilibrium was dependent on the polymer's ability to adsorb to the interface. This is related to the degree of substitution because a more highly substituted polymer has more hydrophobic anchoring groups and therefore is better adsorbed to the interface. Therefore, increasing the degree of substitution decreases the equilibrium value of the interface. No polymer desorption was observed during the droplet formation. This indicates that there is no back diffusion from the interface.

The study also looked at the impact of polymer/weight ratio on droplet size. It was determined that a small polymer/weight ratio was controlled by the amount of polymer available to coat the emulsion particles. There is a minimum polymer layer thickness required to prevent coalescence, therefore as the polymer amount decreases the droplet size increases. This is logical because a fewer number of large particles has a lower total surface area than many small particles. Conversely, for larger polymer/weight ratios the droplet size reaches a minimum where further addition of polymer does not result in a smaller droplet size. This indicates that at larger polymer/weight ratios the droplet size is no longer controlled by the amount of polymer available. The kinetics of emulsion destabilization was also studied. Ostwald Ripening was determined to be the predominant method of emulsion destabilization (Durand, et al. 2004).

### **2.5.5 LCPM Publications: "Neutral Polymeric Surfactants Derived from Dextran: A Study of Their Aqueous Solution Behavior"**

The most recent LCPM publication examined how modified polymeric surfactants, namely modified Dextrans, behave in aqueous solution. The polymer molecules have a tendency to clump together and form aggregates in solution. The research examined the influence of different structural parameters on the aqueous solution behavior. Parameters such as the quantity and type of hydrophobic substitutions were examined. Polymers with different sized hydrophobic substitutions behaved differently. For example, increasing the degree of substitution consequently increased associative behavior in DexC6, whereas it decreased the tendency to form aggregates in DexC10. This inconsistency is explained by the competition between intermolecular and intramolecular forces. Aggregates in solution were detected by viscometry and light-scattering experiments. The study concluded that aggregates do form in dilute solutions when a polymer-specific degree of substitution has been exceeded. These aggregates account for viscous solution behavior. Understanding the interactions between polymer molecules is crucial to understanding the kinetics of polymer-stabilized emulsion formation (Rotureau, et al., 2005).

## ***2.6 Collaboration with WPI***

WPI and ENSIC have a longstanding research partnership. The research presented in this paper was preceded by several other WPI-ENSIC research teams. Undergraduate students from WPI have traveled to Nancy, France to complete their Major Qualifying Projects since 2002. Each group has researched a different aspect of

polymer stabilized emulsions for drug delivery. Some of this research is currently in press for publication in the Journal of Colloids and Surfaces A.

In 2002 Brancato, Miller and Pistorino studied the effect of modifying a Dextran polysaccharide backbone with different hydrophobic substitutions. They studied DexC6, DexC10 and DexC20 as stabilizers for water in oil emulsions. They concluded that any of the three polymers could be used as an effective stabilizer. However, they determined that the oil used, Nujol, had a low affinity for the drug substance, lidocaine. Therefore it was concluded that additional oils should be investigated.

As a direct result from the previous group's conclusions, in 2003 Desmond, Savard and Shea focused on identifying an oil that was better suited for lidocaine encapsulation. They found that 40% Nujol and 30% olive oil produced the desired lidocaine release kinetics. They experienced difficulty maintaining a constant particle size during lyophilization and therefore recommended further optimization studies.

In 2004 Manawanitjareern and Rogers investigated a variety of oils as well as higher Dextran concentrations. Miglyol was the oil with the best experimental results. It was then recommended that further study be devoted to Miglyol. Parameters such as particle size, particle stability, partition coefficient and drug release kinetics would be of interest for further development of oil in water emulsions.

The most recent research was conducted in 2005 by Correia, McElearney and Pinzon. The research focused on DexC6 as an emulsifying polymer. Significant studies were conducted regarding emulsion particle size and particle stability. The particles were found to be stable for one week, but unstable after lyophilization and reconstitution. The study also examined the release kinetics of the lidocaine drug into water and weak buffer

solutions. The buffer solution was used to more closely simulate some of the properties of blood. It was observed that the lidocaine was released more slowly into the buffer solution than the water. It was recommended that more research be performed in the area of particle stability after reconstitution.

The aim of this current study is to further investigate the particle size, stability and release kinetics of DexC6 at a higher polymer concentration. Emulsions containing an aqueous solution of 30g/L and 40 g/L DexC6 in dilute NaOH were tested. The experimental methodology, results and recommendations are detailed in the remainder of this paper.

## **3 Methodology**

### **3.1 Synthesis of Dextran C6 (DexC6)**

The amphiphilic modification of dextran by adding hydrophobic C6 hydrocarbon chains onto the polysaccharide backbone occurred in dimethyl sulfoxide (DMSO) in the presence of tetrabutylammonium hydroxide (TBAOH). The modified dextran was synthesized by adding 150ml of DMSO to 15g of Dextran T40<sup>®</sup> purchased from Amersham Biosciences in Uppsala, Sweden ( $M_w = 40,000\text{g/mol}$ ). The solution was placed in a round bottom flask in an oil bath at 40°C and was mixed for 30 minutes using a magnetic stirrer to allow the dextran to completely dissolve. Once the dextran had dissolved, 75ml of TBAOH at 1M was added to the flask. The new solution was allowed to mix for 20 minutes. After this time had elapsed, 14.2ml of epoxyoctane was added to the solution. This amount of epoxyoctane represented a one-to-one ratio of dextran monomer units to epoxyoctane units. This was calculated as the ratio required to obtain approximately a 15 to 20 percent substitution ratio of hydrophobic groups in the modified dextran. The solution was then allowed to come to room temperature and continue to mix for three days before being placed in a dialysis membrane to begin the polymer recovery process.

#### **3.1.1 Dialysis Purification of the Polymer**

The solution containing the modified dextran polymer needed to be purified of all side products and unused reactants before the polymer could be recovered. Purification by a dialysis membrane was chosen because of the difficulty of precipitating the modified

dextran from DMSO and based on past experimental experience at the LCPM. The size of the pores of a dialysis membrane is indicated by the molecular weight cut off (MWCO) of the membrane. The MWCO is an approximate value for the maximum molecular weight of molecules that can pass through the membrane. However, the size and shape of the molecules is much more significant in determining their ability to escape through the membrane. The proteins used by the manufacturer to test the MWCO of their membrane tend to clump together and take up a larger volume than the modified dextran dissolved in DMSO, which tends to extend into longer, skinnier strands. Therefore a modified dextran of similar molecular weight to the protein used to determine MWCO could escape through a smaller pore. The membrane chosen for the dialysis was a tube-shaped Spectra/Por<sup>®</sup> membrane with a molecular weight cut off (MWCO) of 6,000 to 8,000 g/mol, a width of 40mm, diameter of 25.5mm and a volume to length ratio of 5.1ml/cm. This choice was based on experimental experience at the LCPM. The pores of this membrane have been found to be large enough to let the unreacted epoxyoctane, its byproducts, DMSO and the salts from the TBAOH through, but small enough to keep the larger modified dextran polymer chains within.

The membrane was first cut to size and then placed in a water bath for 10 minutes to ensure thorough wetting and easier handling. The bottom of the membrane was secured with three knots before adding the polymer solution. The top of the tubing was then sealed with three more knots and the membrane was placed into a cylinder containing a 50/50 mixture of 96.2% ethanol (EtOH) and water with a magnetic mixer. The ethanol served the purpose of extracting the unreacted epoxyoctane, its byproducts, and the DMSO, while the water served the purpose of extracting the salts from the

TBAOH. The ethanol was added first so that the differences in the water and ethanol densities could facilitate mixing of the dialysis solution. The ethanol and water solution was changed twice a day for five days. After the five days, the solution was switched to a pure water solution for four days and changed twice daily to complete the dialysis and remove any ethanol that had entered into the membrane so that the product could be freeze dried.

However, on the sixth day of dialysis, when the solution was changed to pure water, the membranes became swollen and one ruptured during handling. The majority of the contents of the membrane were recovered by dropping the ruptured membrane into a nearby Erlenmeyer flask. A new membrane was then prepared and dialysis was continued.

### **3.1.2 Freeze Drying**

After a week of dialysis, the polymer solution had to be centrifuged before it could be freeze dried for recovery. However, it was at this point that the problems with our synthesis became apparent. The polymer solution in the membrane should have been mostly clear with some precipitate. Yet, in this case it was cloudy and not transparent, thus indicating that our polymer may not have been water soluble. We continued with the centrifugation to see if enough precipitate could be removed from the solution to make it clear. The polymer solution was centrifuged using a Jouan GR 20 22 centrifuge at an RCF value of 15,644 g for 30 minutes. The liquid phases were extracted and combined in a round bottom flask for freeze drying and the precipitate at the bottom of the centrifuge tubes was collected in a small jar and stored for later use by the LCPM in a lab refrigerator. The liquid phase was still cloudy at this point and it was decided to

continue with the freeze drying so that the dried product could later be reconstituted with less water and recentrifuged.

The solution was split into two round bottom flasks for freeze drying, making sure not to fill each flask above 20 percent of its volume. Each flask was then placed in a liquid nitrogen bath and turned until all the water inside each flask had frozen. Once the material was sufficiently frozen, the flasks were attached to the freeze dryer. The freeze dryer uses a vacuum to sublime the ice formed within the flasks to dry the product. The flasks were removed from the freeze dryer once all the water had been removed, approximately 48 hours later.

The dry polymer was then collected in a round bottom flask and 50ml of water were added to attempt to dissolve it. After about two hours, the solution resembled a viscous gel and 50ml more water were added to attempt to dissolve the polymer. After a few more hours, the solution no longer resembled a gel but it was thick and opaque and clearly not water soluble. Therefore, the solution was put back into a dialysis membrane and a dialysis solution of 0.1 M NaCl was used for two days, changing the solution every three hours. The presence of the salt ions increased the hydrophobic properties of the polymer, making it precipitate out of solution and collect at the bottom of the membrane, leaving the rest of the solution clear. However, when the dialysis solution was switched back to water, the polymer remained precipitated as a brownish sludge with a gum-like consistency. Therefore, it was certain by this point that our polymer was not soluble and therefore not suitable for further use. The most likely cause for the insolubility of the polymer is that it was allowed to react too long and this resulted in an over hydrophobically substituted polymer. In order to confirm this, we freeze dried the gum

like polymer substance and the polymer solution separately. Once dry, the two samples were prepared for NMR polymer characterization following the procedure in 0 3.1.3 NMR Polymer Characterization to determine the substitution ratios of our polymer. Since it was certain that our synthesis had not produced the desired product, some previously prepared DexC6 with an approximately 20 percent substitution ratio was selected for use in all further experiments.

### **3.1.3 NMR Polymer Characterization**

Although we were using a previously prepared sample of DexC6, the exact substitution ratio was not known. Therefore, the sample had to be characterized using nuclear magnetic resonance (NMR) spectroscopy. Since NMR measures the different types of bonds formed with  $^1\text{H}$  hydrogen isotopes, it is important to ensure that there are no additional  $^1\text{H}$  sources, such as in water or in the solvent used, present. Therefore, about 30mg of polymer was placed in a vial in an oven at  $100^\circ\text{C}$  overnight to dry. Then deuterated DMSO was used to dissolve the polymer because it contains no  $^1\text{H}$  atoms. Deuterated compounds use a heavier isotope of hydrogen,  $^2\text{H}$ , in place of normal  $^1\text{H}$ , therefore the hydrogen atoms do not affect the NMR results. The polymer was allowed to dissolve in the deuterated DMSO solution for an hour before being placed in an NMR tube and being submitted to the lab's NMR technician for analysis.

## ***3.2 Analysis of Lidocaine***

Lidocaine is the model drug used by ENSIC in their drug delivery system research. It was important to evaluate the properties of this drug such as the extinction coefficient, the solubility in dilute NaOH and the partition coefficients of this drug in

different oils in order to understand the behavior of the drug and execute meaningful experiments.

### 3.2.1 Extinction Coefficient of Lidocaine

The extinction coefficient ( $\epsilon$ ) of lidocaine relates the ultraviolet (UV) absorbance to the concentration of lidocaine in the solution being analyzed through Beer Lambert's

$$A = \epsilon [C] l$$

#### Equation 1: Beer Lambert's Law

law, which can be seen in Equation 1, where  $A$  is the optical density or absorbance,  $\epsilon$  is the extinction coefficient or molar absorptivity in units of  $L/mol\ cm$  or  $L/g\ cm$ ,  $[C]$  is the concentration of the compound in units of  $mol/L$  or  $g/L$  and  $l$  is the pass length of the sample in units of  $cm$ . UV spectroscopy was chosen for analysis because lidocaine has an aromatic ring that absorbs UV light, making it very easy to read using the UV spectrophotometer. The chemical structure of lidocaine can be seen in Figure 13.

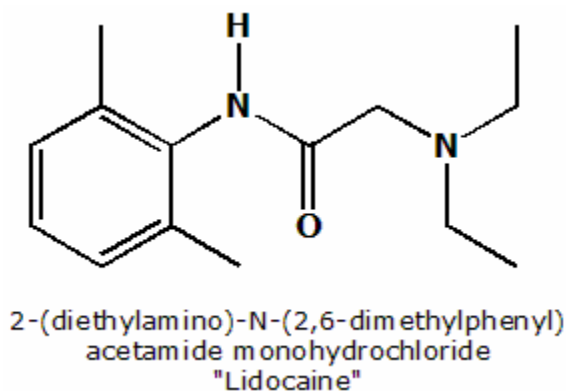

**Figure 13: Chemical Structure of Lidocaine**

<http://encyclopedia.laborlawtalk.com/Image:Lidocaine.png>, 02/08/2006

To determine the extinction coefficient of lidocaine, a plot of the concentration of lidocaine in solution versus its absorbance was required. The plot is linear for lidocaine

concentrations less than 1 g/L and the slope of the line is the extinction coefficient. Therefore a stock solution of approximately 1 g/L lidocaine in  $10^{-4}$  M NaOH was prepared for the analysis. The exact amount of lidocaine and  $10^{-4}$  M NaOH used to make the solution were weighed using a precision scale to determine the exact concentration of the solution because weighing is more accurate than measuring by volume as long as the density of the solution is known. Since  $10^{-4}$  M NaOH is very dilute, the density was assumed to be equal to water. In this case, 0.026g of lidocaine was combined with 25.755g of  $10^{-4}$  M NaOH solution to obtain a lidocaine solution of 0.999 g/L. The solution was allowed to stir overnight to ensure that it was completely dissolved before UV spectroscopy tests were performed.

Before the UV spectrophotometer could be used, it had to be calibrated. The  $10^{-4}$  M NaOH solution was used as the baseline calibration for the machine. A spectrum scan was then run on the NaOH solution to verify that no light was absorbed at all wavelengths. Once the machine was calibrated, the stock solution of lidocaine was used to make solutions with approximate concentrations of 0.25 g/L, 0.5 g/L, 0.75 g/L and 1 g/L. Each of these dilutions was prepared using the precision scale so that the exact concentration of each was known. Each solution was then run through the UV spectrophotometer and the absorbance at the peak of each spectrum scan, corresponding to a wave length of 262 nm, was recorded. Each absorbance was then plotted against its respective concentration and a trend line was added, giving the slope of the line and thus the extinction coefficient of lidocaine.

### 3.2.2 Solubility of Lidocaine

Once the extinction coefficient had been determined, UV spectroscopy could be used to determine the solubility of lidocaine. Approximately 1g of lidocaine was placed in 100mL of  $10^{-4}$  M NaOH solution and allowed to stir overnight. Then the lidocaine solution was centrifuged to collect the undissolved lidocaine so that the saturated lidocaine solution could be removed. The concentration of the saturated lidocaine solution was assumed to be greater than 1 g/L and thus it needed to be diluted for UV analysis. A one to six dilution ratio was chosen and both the amount of saturated solution and  $10^{-4}$  M NaOH solution added were weighed using the precision scale. The diluted sample was then analyzed using UV spectroscopy and the absorbance was recorded. Using the extinction coefficient previously determined, the concentration of the sample was less than 1 g/L and no further dilution was needed. The actual saturation concentration of the lidocaine was then back calculated based on the amount the sample was diluted.

### 3.2.3 Partition Coefficients ( $K_p$ )

In order to measure the differential solubility of a compound in two solvents, the partition coefficient,  $K_p$ , must be determined. The partition coefficient is the ratio of the solute concentration in the desired solvent to the solute concentration in the undesired solvent as seen in Equation 2. In this case, the solute is lidocaine, the desired solvent is oil and the undesired solvent is  $10^{-4}$ M NaOH solution made with MilliQ water.

$$K_p = \frac{[Lidocaine]_{oil}}{[Lidocaine]_{dilute\ NaOH}}$$

**Equation 2: Partition Coefficient**

To determine the partition coefficient, two methods were used. In the first, lidocaine was dissolved in a known volume of oil and then the oil was mixed with a known volume of dilute NaOH solution. In the second, lidocaine was dissolved in a known volume of dilute NaOH solution and then the dilute NaOH solution was mixed with a known volume of oil. In both cases, the phases were shaken and then stirred with a magnetic stir bar and then allowed to separate before the aqueous phase was extracted for UV spectroscopy to determine the concentration of lidocaine. Equation 3 was used to calculate the partition coefficient.

$$K_p = \frac{(x - [\textit{Lidocaine}]_{\textit{dilute NaOH}} \times z)}{(y \times [\textit{Lidocaine}]_{\textit{dilute NaOH}})}$$

**Equation 3: Partition Coefficient (rearranged)**

Where  $x$  represents mg of lidocaine,  $y$  represents mL of oil, and  $z$  represents mL of dilute NaOH. Everything was weighed using a precision scale so the exact quantities would be known.

### 3.2.4 Oil Purity

The partition coefficients of four different oils were determined. However, before the partition coefficients could be determined, the oils had to be washed to remove any impurities that may affect the UV analysis. Small amounts of each oil (5ml) were washed three times with  $10^{-4}$ M NaOH. After the third washing, samples of the aqueous solution were tested with UV spectroscopy to determine purity. If the oils were pure, the UV spectrum, baselined with pure  $10^{-4}$ M NaOH, would record no absorbance. If the oils were not clean, the washing was repeated. When clean, the oils were ready for use in partition coefficient experiments. The four oils under investigation were dicarylyl

carbonate, caprillic-capric triglyceride, octyldodecanol, and miglyol. The most suitable oil, determined by partition coefficient experiments, was then washed in large quantities for emulsion experiments.

### **3.3 Emulsions**

The preparation and creation of emulsions was critical to our experiments. Emulsion properties such as the size and stability of the oil in water particles would affect the encapsulation and release properties of our drug. This section explains the preparation and creation of emulsions and the tests done to determine the size and stability of the emulsions using DexC6 concentrations of 30g/L and 40g/L in the aqueous phase. The results from these experiments determined which DexC6 concentration would be used for lidocaine encapsulation.

#### **3.3.1 Emulsion Preparation**

Emulsions were prepared in 10mL batches in 50mL plastic sonication tubes. Each emulsion was comprised of 6mL of aqueous solution and 4mL of oil solution. The aqueous solution was  $10^{-4}$ M NaOH. It had to be kept tightly sealed and the pH checked periodically to maintain the dilute concentration. DexC6 concentrations of 30g/L and 40g/L in the aqueous phase were used depending on the experiment. The DexC6 was allowed to dissolve overnight in the aqueous solution. The oil phase was octyldodecanol. It was determined that this oil had the most favorable results from the partition coefficient experiments.

Once the appropriate amount of DexC6 had dissolved overnight in 6mL of aqueous solution, 4mL of oil solution were added to the 50mL sonication tube. Prior to

sonication, the material in the sonication tube was vortexed at a speed of 2500 rpm for one minute. All components added to the sonication tube were weighed using a precision balance so that the exact quantities were known.

### **3.3.2 Emulsification**

Emulsions were prepared using sonication. Sonication is a high energy process that delivers ultrasound waves to the oil and water mixture, disrupting the two immiscible phases and allowing them to mix. Due to this high energy disruption, very small emulsion particles form and the role of the amphiphilic polymer is to stabilize these emulsions. The Vibra-Cell sonication equipment by Bioblock Scientific was used to prepare all emulsions.

The sonication probe was lowered into the sonication tube so that the tip was just below the separation of the two phases. A line was marked on the probe to ensure that the probe would be placed at exactly the same spot on all successive sonications. Careful attention was paid to ensure that the probe did not touch the walls of the tube. The portion of the tube containing the emulsion was submerged in a water bath to help dissipate the heat released during sonication.

A sonication time of 210 seconds was chosen for an active cycle of 50 percent and a power level of 5, which is approximately equivalent to 100W. These settings remained constant for all sonications. Once the sonication was complete, the emulsions had been formed and were ready for experiments and testing.

### **3.3.3 Particle Sizing**

A High Performance Particle Sizer (HPPS) by Malvern Instruments was used to measure the size of our emulsion particles. The HPPS measures the retro-diffusion of light from particles in a solution using a Neon-Helium laser reading from multiple angles. This method allows for measurements of particles from solutions of high concentration and over a wide range of particle sizes, from 0.6 to 6000 nm, as well as minimizing sources of error such as dust particles. Since it is impossible to make emulsions of uniform size, the HPPS gives only an average size for three different runs for each sample, with between eight and twenty measurements per run. The HPPS also provides a polydispersity value for each set of runs, which is a number indicating how widely the distributed the particle sizes were within each sample. Samples with a polydispersity value greater than 0.4 were deemed to have too wide a particle size distribution to be considered useful. Samples with too high of a polydispersity value were discarded and redone.

To prepare samples for the HPPS, a 0.001M NaCl solution was prepared to dilute the emulsions. The HPPS cuvette was filled half way with NaCl solution and one drop of emulsion was added. The sample was then mixed, bubbles were eliminated, the cuvette face was cleaned and then placed in the machine for analysis. Initial particle sizes were measured one hour after sonication to allow any bubbles formed during the sonication process to settle.

### **3.3.4 Emulsion Stability**

Two methods were employed to test the stability of the emulsions. The first was to measure the particle sizes of the emulsions 24 hours after sonication and then again

after 96 hours to see if the average particle size increased. The second method used to evaluate the stability of the emulsions involved centrifuging the emulsions and then measuring the particle size. The forces applied by the centrifuge acted as a method to artificially age the emulsions by encouraging them to separate back into two phases. The emulsions were placed in the Jouan GR 20 22 centrifuge at an RCF value of 109 g for 10 minutes. The size of the emulsion particles was then measured using the HPPS to see if the size had increased. Smaller deviation in the particle size measured during both methods meant a more stable emulsion.

### **3.3.5 Emulsion Reconstitution**

The last test performed on the emulsions was to examine their ability to be reconstituted after freeze drying. Freeze drying allows the emulsions to be dried without being chemically altered. Dry emulsions could hopefully be stored for longer periods of time without their composition being altered and then be reconstituted before an application. This would improve their shelf life and thus their usefulness as a conduit for drug delivery in the medical world.

For the freeze drying process, 5mL emulsion samples were placed in small centrifuge tubes, frozen and then dried for a period of 48 hours. The dry emulsions were then reconstituted by adding an amount of MilliQ water equivalent to that removed during the drying process, 3mL. The solutions were vortexed for one minute and then placed in a sonication bath for 15 minutes. The particle sizes for the reconstituted emulsions were then evaluated using the HPPS machine.

### ***3.4 Lidocaine Encapsulation***

Lidocaine is the drug used by ENSIC to model their emulsion based drug delivery system. Lidocaine was dissolved in the oil phase of the emulsion in a concentration of 25mg/mL. To accomplish this, the same emulsification procedure described in 0 3.3.1 Emulsion Preparation and 0 3.3.2 Emulsification was used with the exception that 40g/L was the only DexC6 concentration used. Exact amounts added were always weighed using a precision scale. Also, the lidocaine was allowed to dissolve in the oil phase overnight in a separate 50mL sonication tube. The aqueous phase containing DexC6 was added to the oil phase before the sonication process. The lidocaine-encapsulated emulsions were tested for particle size as in 0 3.3.3 Particle Sizing and for stability with time only as in 0 3.3.4 Emulsion Stability.

### ***3.5 Lidocaine Release Kinetics***

The release kinetics of lidocaine were studied to determine the rate at which lidocaine was being released from its encapsulated emulsion to an external medium. This information is important in the medical world because it is critical to know how much drug is being released into a patient's body and at what rate, so that overdose situations can be prevented and so that the useful life of a drug dose can be determined. In order to show how a lidocaine-encapsulated emulsion releases lidocaine compared to non-encapsulated lidocaine, release kinetics experiments were carried out for lidocaine alone, for lidocaine in the presence of DexC6 and for lidocaine-encapsulated emulsions.

The external medium in all release experiments was the same aqueous solution of  $10^{-4}$ M NaOH used throughout all experiments. Having the external medium be the same

as the aqueous phase of the emulsion eliminated any additional driving forces of mass transfer other than molecular diffusion. The release experiments were done using Spectra/Por dialysis membranes containing the lidocaine solutions in a dialysis solution of the external medium. For all release experiments, the amount of dialysis solution was equal to 2mL for every 1mg of lidocaine contained within the dialysis membrane. Before any experiments could be performed, the dialysis membrane had to be washed in a bath of DI water. A UV spectrum was run on the bath solution to see if the membrane was clean. If it was not, the washing process was continued until the UV spectrum showed that the membrane was clean.

### **3.5.1 Lidocaine Release**

A 10mL solution with a lidocaine concentration of 3g/L was allowed to dissolve overnight. The solution and lidocaine added were weighed using a precision scale to know the exact amounts contained in the solution. The solution was then poured into the dialysis membrane, which was double knotted at both ends and then placed in the dialysis solution. 60mL of dialysis solution were used for this experiment. Samples were removed from the dialysis solution for UV analysis to determine the amount of lidocaine present on a regular basis, approximately every 15 minutes. Samples were returned to the bath after analysis.

### **3.5.2 Lidocaine Release in the Presence of DexC6**

A 10mL solution with a lidocaine concentration of 3g/L and a DexC6 concentration of 40g/L was allowed to dissolve overnight. The solution, lidocaine and DexC6 added were weighed using a precision scale to know the exact amounts contained

in the solution. The solution was then poured into the dialysis membrane, which was double knotted at both ends and then placed in the dialysis solution. 60mL of dialysis solution were used for this experiment. Samples were removed from the dialysis solution for UV analysis to determine the amount of lidocaine present approximately every 30 minutes. Samples were returned to the bath after analysis.

### **3.5.3 Lidocaine Release from an Emulsion**

A lidocaine-encapsulated emulsion was prepared and emulsified according to section 0 3.4 Lidocaine Encapsulation. The exact amounts added were weighed using a precision scale. The emulsion was then poured into the dialysis membrane, which was double knotted at both ends and then placed in the dialysis solution. 200mL of dialysis solution were used for this experiment. Samples were removed from the dialysis solution for UV analysis to determine the amount of lidocaine present approximately every 30 minutes. Samples were returned to the bath after analysis.

## 4 Results and Discussion

### 4.1 Synthesis of Dextran C6 (DexC6)

The synthesis of Dextran C6 was executed according to the procedure outlined in LCPM publications (Rotureau, et al, 2005). The hydrophilic Dextran T40 starting material was modified with epoxyoctane to yield DexC6, an amphiphilic Dextran polymer substituted with hydrophobic hexane groups. The reaction appeared to process normally; however, later problems were attributed to this synthesis. It is likely that the substitution reaction with epoxyoctane was allowed to process for 3 days, which was too long. This resulted in a polymer that was more substituted than desired. Too much hydrophobic substitution yielded a polymer that was no longer water-soluble. The synthesized polymer was therefore unusable for oil in water emulsion preparation. Because the synthesis and purification took a significant amount of time it was impractical to synthesize another batch of DexC6. Therefore, for experimentation we used a previously synthesized batch of DexC6 that was stored in the lab.

NMR spectroscopy was used to confirm the initial hypothesis that the epoxyoctane substitution reaction was allowed to proceed for too long. The goal was to obtain a sample of DexC6 with an alkane chain substituted onto approximately 20% of the Dextran sugar units. The NMR spectrum of the desired molecule is shown in Figure 14. The peaks corresponding to the different parts of the polymer molecule are identified by their position on the graph. The group of peaks on the right corresponds to the substituted alkane chains, whereas the group of peaks on the left represents the Dextran backbone. By comparing the areas of these peaks, it is possible to calculate the

ratio of substituted Dextran sugar units to unsubstituted Dextran sugar units. The sample shown in

Figure 14 had a substitution ratio of approximately 20%. This sample had been made previously by another student and was used in all of our experiments.

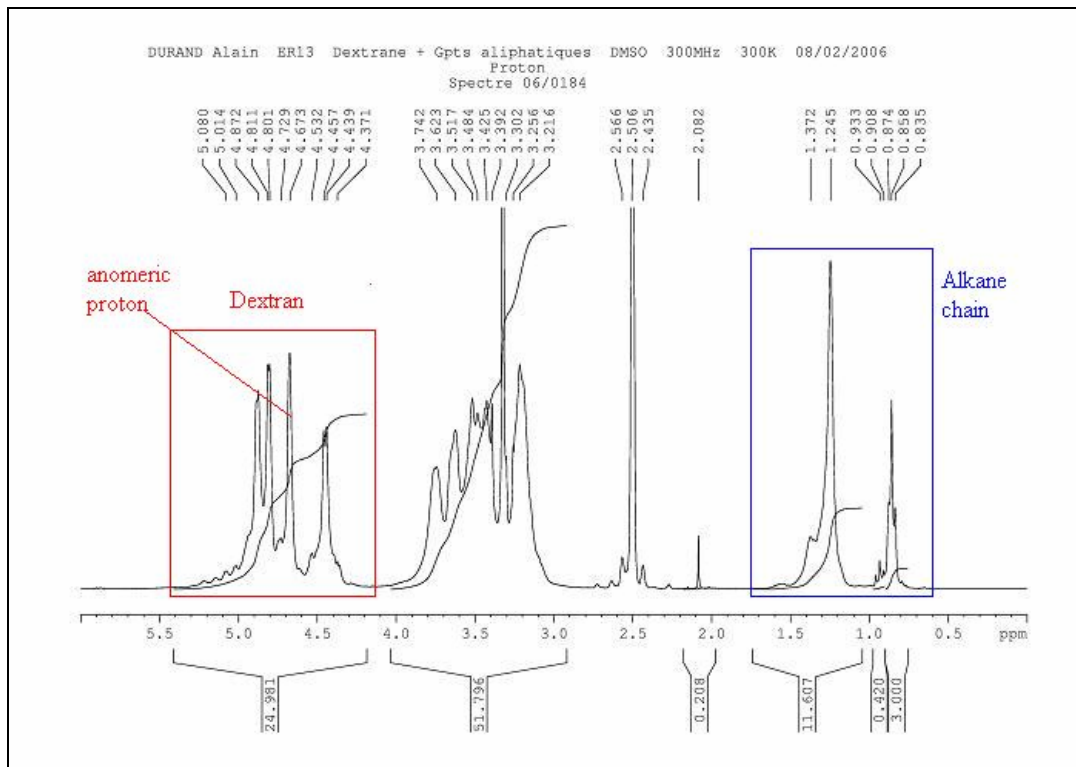

**Figure 14: NMR spectrum of 20% substituted DexC<sub>6</sub> used in experimentation**

When it became apparent that our synthesis of DexC<sub>6</sub> had not processed as expected we began to investigate the cause of this error. An NMR spectrum was run to check for problems with the substitution ratio. The NMR data from our problematic synthesis is shown in Figure 15. It is clear that the ratio of the peak sizes of alkane to Dextran is much larger than in the previous sample. The calculated substitution ratio was approximately 55-60%. This confirms the hypothesis that our synthesis had reacted for

too long and was therefore over substituted. This explains the problems experienced with the sample we synthesized and supports the decision to use a pre-made sample.

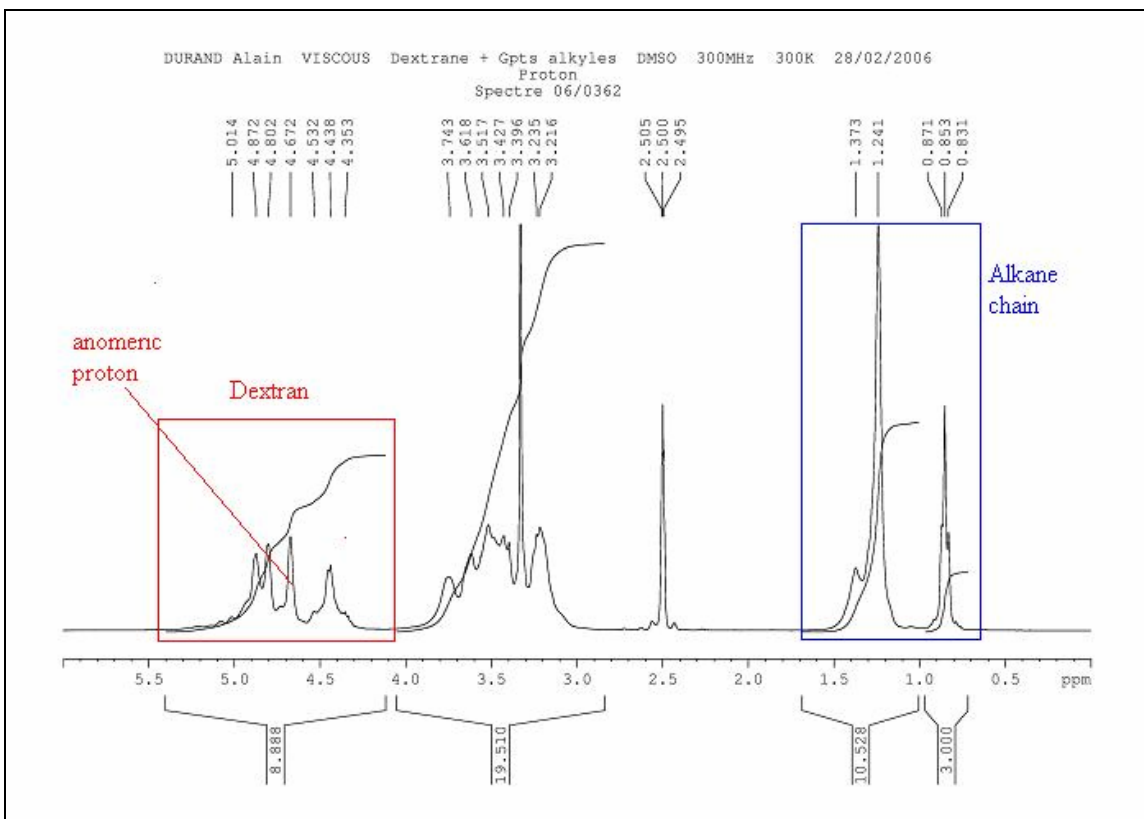

Figure 15: NMR spectrum of problematic synthesis

#### 4.1.1 Dialysis Purification of the Polymer

To remove excess reactants and solvents the polymer solution was placed in tubular Spectrum® membranes for dialysis purification. The first phase was processed with a dialysis solution of 50/50 ethanol in water. This would normally process for three days, however our experiment processed for five days due to the fall of a weekend during the initial dialysis phase. The second purification phase was dialysis with pure distilled

water. This processed for four days in order to remove and ethanol that may have passed into the membrane. The first dialysis phase processed normally; however, there were significant complications with the pure water dialysis.

#### **4.1.2 Overcoming and Preventing Membrane Rupture**

Our polymer solution was contained in two separate dialysis membranes in two separate cylinders containing the dialysis solution. On the sixth day of the dialysis, the solution was switched from a 50/50 solution of ethanol and water to a solution of pure water.

The dialysis mechanism operates based on equilibrium. The undesired solvents, byproducts and excess reactants remaining in the polymer solution within the membrane diffuse through the membrane to achieve equilibrium in the dialysis solution. In the same manner, the ethanol and water in the dialysis solution diffuse through the membrane to achieve equilibrium in the polymer solution. As previously mentioned, the membrane was selected to prevent the DexC6 polymer from escaping. Therefore, by frequently changing the dialysis solution, the undesired products that had diffused out of the membrane were removed and the equilibrium was upset such that more undesired product was forced to diffuse into the dialysis solution to restore the equilibrium.

On the sixth day of the dialysis, the solution was switched from a 50/50 solution of ethanol and water to a solution of pure water. During the first day of pure water dialysis we encountered a significant problem when the dialysis membrane ruptured during a routine dialysis solution change. The tubular membranes were removed from the solution and gently turned several times to mix the sediment within the membranes. During turning one membrane sprang a small leak. We were able to contain most of the

spill in a beaker before the membrane tore completely. The cleanliness of the beaker was questionable. The material collected from the ruptured membrane was put into another membrane and continued the dialysis process.

There are several factors that attributed to the rupture of the membrane. By the sixth day, the membrane contained a significant amount of ethanol and water and when the dialysis solution was switched to pure water, the membrane initially floated. However, throughout the day, due to the same equilibrium mechanism, water entered the membrane and the osmotic pressure within the membrane increased until the membranes were swollen and about to burst. Prior to rupture, the membrane was noticeably more swollen than it was when initially placed into the water dialysis solution. This indicates that more solution diffused into the membrane than out of it. Purification by dialysis is driven by equilibrium and permeability of a substance through a membrane. There was a significant ethanol concentration within the membrane and no ethanol in the dialysis solution. Over time equilibrium dictates that ethanol will diffuse out of the membrane and into the dialysis solution in order to obtain equal ethanol concentrations. Ethanol is a molecule more than 2.5 times larger than a water molecule. Therefore it would seem that it is easier for a water molecule to diffuse through a membrane than an ethanol molecule. The drive for equilibrium may have initially driven water into the membrane in attempt to dilute the ethanol rather than driving the ethanol out of the membrane in order to obtain equal concentrations. This explanation is plausible because when the dialysis solution was switched to pure water, the membrane initially floated, indicating it contained a significant amount of ethanol. However, throughout the day, due to the same equilibrium mechanism, water entered the membrane and the osmotic pressure within the membrane

increased until the membranes were swollen. This influx of liquid put a strain on the membrane and made it more prone to breakage.

It is interesting to note that the previous project group that performed the same procedure had a similar problem with membrane rupture at approximately the same point in the dialysis. It may be worth modifying the dialysis procedure to adjust time intervals of solution change or gradually reducing the concentration of ethanol in order to prevent membrane rupture in the future.

## ***4.2 Analysis of Lidocaine***

Prior to conducting any emulsion experiments we had to gather data about the model drug substance, Lidocaine. One of the reasons Lidocaine was chosen is because it has a much greater solubility in oil than water. It is not completely insoluble in water, therefore we conducted several experiments to gather more information about the solubility properties of Lidocaine.

### **4.2.1 Extinction Coefficient of Lidocaine**

The first task was to develop a standard curve using dilute Lidocaine solutions of known concentration. Four solutions were prepared and analyzed using UV spectroscopy. Beer's Law dictates the linear relationship between UV absorbance and solution concentration.

$$A = \varepsilon [C] l$$

**Equation 4 : Beer Lambert's Law**

Therefore, by plotting absorbance by solution concentration the extinction coefficient,  $\epsilon$ , can be calculated as the slope of the line. This is shown in Figure 16.

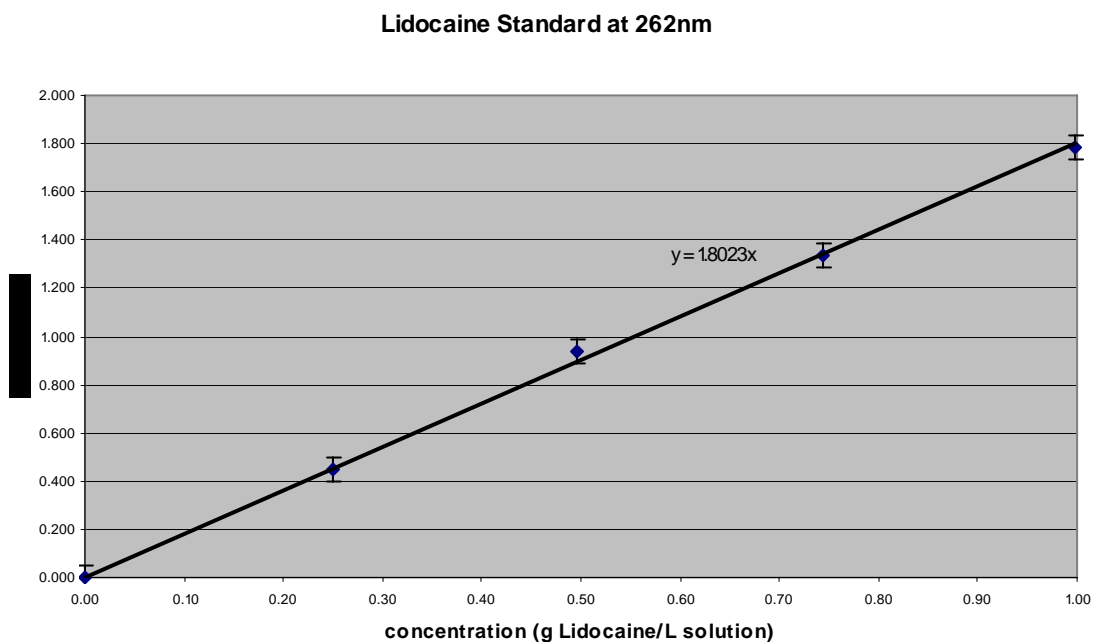

**Figure 16 : Standard curve of Lidocaine solubility**

The extinction coefficient was calculated to be  $1.8023 \text{ L g}^{-1} \text{ cm}^{-1}$ , which is consistent with previous research. This information is very useful because for subsequent calculations we were able to measure the concentration of dilute Lidocaine solutions using UV spectroscopy.

#### **4.2.2 Solubility of Lidocaine**

We attempted to calculate a maximum solubility limit for Lidocaine in water, however, this proved to be somewhat problematic. Our first experiment yielded a saturation concentration of  $4.147 \text{ g/L}$ . However, on other occasions we were unable to

get this much Lidocaine to dissolve in water. Therefore the saturation concentration is inconsistent and not reproducible.

There are several possible explanations for this. Variations in temperature and mixing time could have an effect on the amount of Lidocaine that dissolves. We tried two different separation techniques to remove the undissolved Lidocaine, centrifugation and filtering. Neither method worked very well. There is also a very good possibility of human experimental error involved in separation and dilution.

To account for this inconsistency we made a fresh saturated Lidocaine solution whenever it was needed. We would then determine the concentration by diluting the sample and measuring its UV absorbance.

#### **4.2.3 Partition Coefficients ( $K_p$ )**

Partition coefficient ( $K_p$ ) experiments were conducted for four different oils: dicaprylyl carbonate, caprylic/capric triglyceride, octyldodecanol and miglyol. The experiments mixed each of the oils with a dilute NaOH solution saturated with lidocaine. Three separate trials were run, each with a different volume ratio. In each case, octyldodecanol was calculated to have the highest  $K_p$  value. This data is shown in Figure 17.

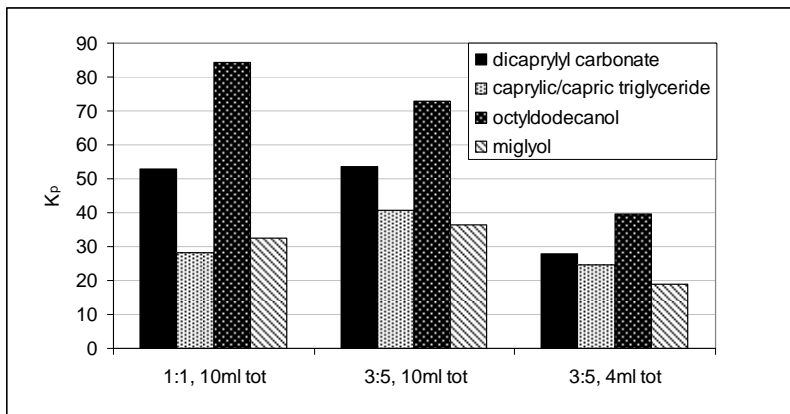

**Figure 17: Partition coefficient results**

Although octyldodecanol is the best oil in each trial, the actual  $K_p$  values are not consistent. This can be attributed to two causes. First, each experimental trial was prepared with a different ratio of oil volumes, which may have affected the final results. Theoretically this should not impact the  $K_p$  value, however, variations in preparation, small sample sizes and the discrepancy of the UV spectrometer on a day-to-day basis may have had a significant impact. Secondly, there were significant problems preparing lidocaine solutions of the same concentration due to the low solubility of lidocaine in aqueous solutions. There is no measure of the error calculation because each trial was run only once. As a result of this data, octyldodecanol was chosen for further experimentation.

Octyldodecanol was the only oil used in the second set of experiments. Rather than dissolve the lidocaine in aqueous solution, this procedure used lidocaine dissolved in the oil. The experiment was repeated four times for consistency and it was determined that octyldodecanol had a  $K_p$  of  $62 \pm 3$ . These results are much more consistent than the first set of experiments.

### ***4.3 Optimization of Emulsion Parameters***

LCPM had never made oil in water emulsions consisting of forty percent oil before. Therefore, it was necessary to determine what concentration of modified dextran polymer was required to produce stable emulsions with particle sizes at or smaller than 300 nm. The two polymer concentrations studied were 30g/L and 40g/L in a  $10^{-4}$ M NaOH solution that comprised the aqueous phase of the emulsion. In order to test the stability of the emulsions, the particle size over time, the particle size after artificial aging in a centrifuge and the particle size after reconstitution were studied. No lidocaine was present in any of these emulsions, the only goal here being to determine the best polymer concentration to be used in lidocaine encapsulation and release kinetics experiments.

As mentioned in the methodology section, all particle size measurements were made with the High Performance Particle Sizer (HPPS). After sonication, emulsions were stored at room temperature and particle sizes were measured at 24 and 48 hours. The emulsion from the first trial was then split, one half was centrifuged for artificial aging and the other half was freeze dried so that it could be reconstituted later. The particle sizes of the artificially aged emulsions were measured immediately after they were removed from the centrifuge. The freeze dried emulsions were reconstituted using the same volume of MilliQ water that was removed. The emulsions were then vortexed for one minute and placed in a sonication bath for 15 minutes, after which the particle sizes were evaluated. The results presented in Table 1 show the average particle size for three runs on the HPPS with its standard deviation for each trial.

**Table 1: Average Particle Sizes of Emulsions**

<b>Emulsion</b>	<b>24 hrs (nm)</b>	<b>48 hrs (nm)</b>	<b>Centrifuged (nm)</b>	<b>Reconstituted (nm)</b>
<b>30g/L Trial 1</b>	317 ± 5	352 ± 8	453 ± 10	293 ± 3
<b>30g/L Trial 2</b>	355 ± 5	349 ± 3	N/A	N/A
<b>40g/L Trial 1</b>	273 ± 2	284 ± 1	281 ± 3	248 ± 5
<b>40g/L Trial 2</b>	284 ± 2	289 ± 5	N/A	N/A

As can be seen from the table, the emulsion with a 40g/L concentration was already superior at 24 hours because it had particle sizes below 300 nm, one of the main criteria, while the emulsion with a 30g/L polymer concentration had particle sizes above 300 nm. By 48 hours, the average sizes for 40g/L have changed little and are still below 300 nm while the average sizes for 30g/L are around 350 nm. The greatest difference was shown after the artificial aging in the centrifuge. The average particle size for 30g/L was well above the 300 nm desired value while the particle sizes for the emulsion with 40g/L had not increased at all. When it came to the particle sizes of the reconstituted emulsions, both were below 300 nm but the average size for 40g/L was still significantly below that of 30g/L. The particle size superiority of the 40g/L polymer concentration can be seen in Figure 18.

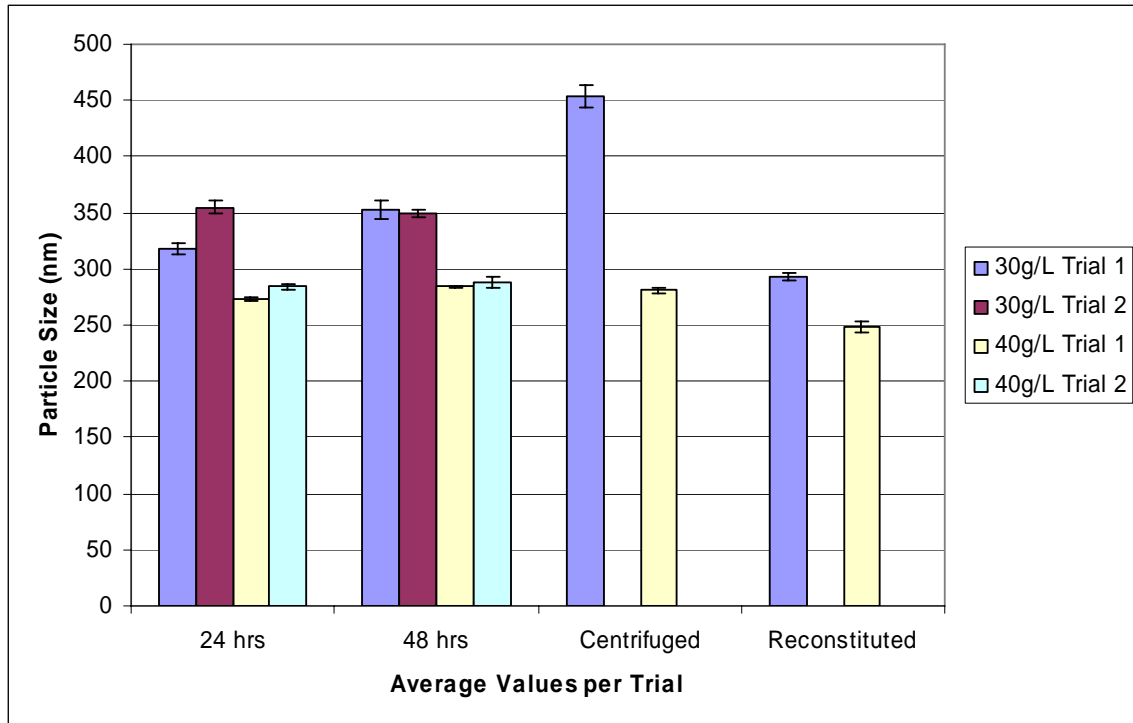

**Figure 18: Emulsion Particle Size Comparison**

In every case, the particle sizes for emulsions with a polymer concentration of 40g/L are below 300 nm and smaller than those for emulsions with a polymer concentration of 30g/L. The stability of the particles was also better for the 40g/L concentration. This is most evident by looking at the results of the artificial aging of the emulsions in the centrifuge. The particle sizes for the emulsion with a polymer concentration of 30g/L experienced a significant increase after being centrifuged, showing that 30g/L is not a high enough polymer concentration to produce stable emulsions. On the other hand, the particle sizes for the emulsion with a polymer concentration of 40g/L remained relatively constant after centrifuging.

The concentration of 40g/L was expected to produce smaller particle sizes and have greater stability than the concentration of 30g/L. However, the objective was to be able to use the least amount of polymer necessary to make emulsions that met our criteria. A polymer concentration of 30g/L was not enough to effectively stabilize the surface area

of the oil, while 40g/L proved to be sufficient. The only unexpected result was the particle sizes of our reconstituted emulsions. The results of past WPI groups working with modified dextran stabilized oil in water emulsions had shown that the particle sizes for reconstituted emulsions were much larger than the initial sizes had been prior to freeze drying. This increase in size ranged from 57 nm to 571 nm (Correia, McElearney and Pinzon, 2005). Both of our reconstituted emulsions had lower average particle sizes than their initial particle sizes. This is a positive result showing that emulsions can be reconstituted within the desired particle size range. However, this could also be due to having much larger concentrations of polymer in our emulsions and a higher oil percentage, meaning that less of the emulsion structure was removed during freeze drying. This may have helped the stability of the dry emulsions. Also, our reconstituted emulsions were vortexed and placed in a sonication bath, which probably also contributed to the lower particle sizes. Still, these are interesting results that should be investigated further to understand the effects polymer concentration and oil percentage in an emulsion have on the ability to effectively reconstitute emulsions.

#### ***4.4 Lidocaine-Encapsulated Emulsion Stability***

Lidocaine-encapsulated emulsions were made with a polymer concentration of 40g/L in the aqueous phase. A couple of these emulsions were tested to determine particle size and stability with time. Particle size measurements were taken at 24 and 96 hours. As can be seen in Table 2 the initial particle sizes for both emulsions are below the desired 300 nm size. The emulsions were stored at room temperature and by 96 hours the particle sizes for both emulsions had grown above 300 nm, but were not unreasonably large. Still, the stability of the emulsions was slightly less than desirable. In order to

obtain better stability results in the future, it is suggested to store the emulsions in a refrigerated setting, which should slow particle growth.

**Table 2: Lidocaine Emulsion Particle Size**

Emulsion	24 hrs (nm)	96 hrs (nm)
1	297 ± 3	339 ± 5
2	285 ± 1	327 ± 6

## ***4.5 Lidocaine Release Kinetics***

Kinetics tests were performed to understand how the rate of lidocaine release from a lidocaine-encapsulated emulsion compared to a solution of just lidocaine and a solution of lidocaine and modified dextran. This testing was useful to show how a lidocaine-encapsulated emulsion might be used to provide controlled drug delivery in an intravenous application. The experimental model used here assumed that the main mechanism of drug release was molecular diffusion and the results from the experiments can be seen in Figure 19.

Some problems were encountered during the release kinetics testing. The most significant problem was the  $10^{-4}$ M NaOH solution. The dilute NaOH solution was problematic due to its instability. The solution was initially chosen to constitute the aqueous phase of our emulsions because of lidocaine's strong dependence on pH. However, the NaOH solution was dilute to the point that the pH was constantly changing even though the solution was always tightly covered. Small amounts of water absorbed into the NaOH solution from the air could change the pH of the solution significantly over the course of a day. While the pH of the solution was checked and brought back to approximately 10 daily, the rate of degradation of the pH during the experiments was unknown. The UV spectrophotometer was baselined with NaOH solution that had been

properly adjusted at the beginning of each experiment but the degradation of the NaOH solution used in the experiments could have led to inaccurate UV analysis. The release experiments were also only run over one day, approximately 7 hours. Due to the degradation of the NaOH solution, results obtained after one day were unreliable.

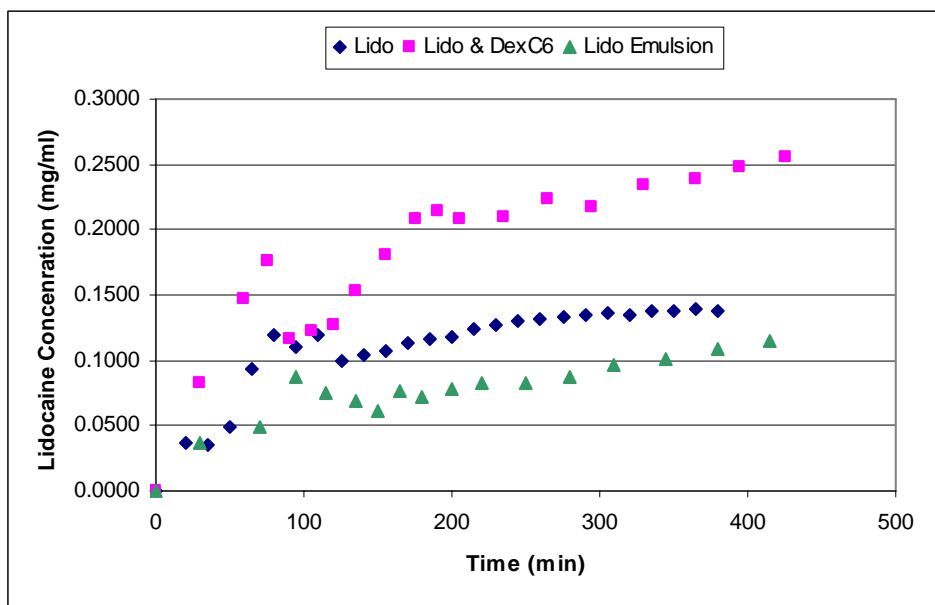

**Figure 19: Lidocaine Release Kinetics Comparison**

The building also lost power briefly during the release experiments with lidocaine and modified dextran and the lidocaine-encapsulated emulsion. Therefore, the UV spectrophotometer had to be baselined again once the power returned and this could have contributed to some error as well. However, although the error due to the NaOH solution negates the quantitative certainty of our results, we feel that the trends exhibited by our results are still useful to analyze.

According to Figure 19, the lidocaine and DexC6 solution had the fastest rate of release. Yet, it is more likely that DexC6 molecules were able to escape through the large pores of the membrane along with the lidocaine because the lidocaine only curve and the lidocaine and DexC6 curve were expected to be the same. The DexC6 present in

the dialysis solution removed for UV analysis would have added to the measured absorbance, thus making it seem as if the concentration of lidocaine in the solution was higher than it actually was. In order to determine the actual absorbance of the lidocaine, it would have been necessary to determine what the presence of DexC6 adds to the extinction coefficient of lidocaine. However, there was not time to do this and therefore the results from the lidocaine and DexC6 release study will be excluded from further discussion.

The lidocaine only curve and the lidocaine emulsion curve show that the rate of release from the emulsion was slower than from the lidocaine only solution. The initial sharp increase in concentration on the emulsion curve has been explained in previous years as a release of unencapsulated lidocaine from the aqueous phase of the emulsion. However, we do not think that this is the case here because an initial sharp increase in concentration was experienced in all the release experiments, all at a similar time in the release experiment. A possible explanation for this sharp increase is that the dialysis solution was not well stirred. The dialysis solution was very gently stirred by a small magnetic stir bar on the lowest possible rpm setting. This was done because molecular diffusion was assumed to be the main mechanism of drug release and we did not want to introduce any convective mass transfer by stirring the dialysis solution. By not stirring the solution, a strong concentration gradient developed initially in the dialysis solution which affected the results of the UV analysis. Mass transfer proceeds from a higher concentration to a lower concentration. Therefore it is reasonable that the initial release proceeded at a fast rate. However, after a long enough time, it appeared that lidocaine

had diffused throughout the dialysis solution and perhaps the weak stirring also had some effect to weaken the concentration gradient and the release rate slowed.

In order to avoid a concentration gradient that can affect results, we suggest that release kinetics experiments be done in the future with a well mixed dialysis solution. While this will introduce convective mass transfer to the experiments, we feel that this would actually be more useful for studying the release kinetics of a drug delivery system intended to be used intravenously. Since blood flows throughout the body, emulsions delivered intravenously would be exposed to convective mass transfer and their release would not just be governed by diffusion. Therefore we feel that having a well mixed dialysis solution would produce more accurate and more useful results.

Analyzing the lidocaine and the lidocaine emulsion curves after the initial peaks in concentration shows that the emulsion releases lidocaine at a slower rate than the lidocaine only solution. This was the desired result. Encapsulating lidocaine in an emulsion is not only a method for delivering a poorly water soluble drug to the body, but also a method for controlled drug release. By releasing drug at a slower rate, dangerous peaks in drug concentration can be avoided and a longer period can elapse between doses. However, another study would be needed to gather data over a longer time period with more accurate results. In order to do this, it would be necessary to choose another aqueous phase that is more stable than dilute NaOH. It would also be advantageous to have a well mixed dialysis solution for the release kinetics experiments to avoid concentration gradients and model convective mass transfer. Still, the current results are promising that drug encapsulated emulsions are useful for delivering oil soluble drugs into the body in a controlled manner.

## 5 Conclusions and Recommendations

The goal of this study was to investigate the use of DexC6 as a surfactant in oil in water emulsions, to determine its effect on the stability and size of emulsions as well as its impact on the release of the model drug lidocaine from emulsions. To accomplish this goal, modified dextran was synthesized, physical properties such as drug solubility and partition coefficients were determined and the stability of the emulsions along with the release kinetics of lidocaine were observed.

Our synthesis of modified dextran was a failure due to over substitution during the reaction process. The reaction was carried out for three days rather than two, therefore substitution ratios of 55-60 percent were observed instead of the desired 20 percent. This made the modified polymer insoluble in water and thus unusable. In the future, it is suggested that the duration of the reaction be verified multiple times to avoid any such oversight.

During the purification process of our synthesis, one of the dialysis membranes ruptured. This was the second membrane rupture in two years. In order to avoid such rupture in the future it is recommended to make smaller membrane tubes, to always have a safety beaker nearby when changing the dialysis solution, to be very cautious on the day the dialysis solution is switched to pure water and to change the dialysis solution more frequently, approximately every three hours, on that day.

The extinction coefficient of lidocaine was calculated to be  $1.8023 \text{ L g}^{-1} \text{ cm}^{-1}$  which agreed with known literature values. The solubility of lidocaine in the dilute NaOH solution was approximately 4.147 g/L, however this was not a reproducible result due to the instability of the pH of the NaOH solution and variations in temperature and

mixing time. The solubility of lidocaine of a saturated sample was determined each time it was needed and to ensure solubility, lidocaine solutions were prepared with a concentration of approximately 3 g/L.

The partition coefficients of lidocaine for four different oils were determined. Octyldodecanol had the highest partition coefficient through experimentation of  $62 \pm 3$  [(g lidocaine/mL oil)/(g lidocaine/mL NaOH soln)]. This value was much higher than the value obtained for miglyol last year; therefore octyldodecanol was used for all emulsion and release kinetics experiments.

This year was the first year emulsions had been made with 40 percent oil. Therefore, different polymer concentrations were tested to determine which produced the most stable emulsions with the smallest initial particle size. A DexC6 concentration of 40 g/L was determined to be the best, producing initial particle sizes below the desired 300 nm and showing the least deviation in size with time, artificial aging in a centrifuge and after reconstitution. A DexC6 concentration of 40 g/L was therefore used in all drug release kinetics experiments.

The lidocaine release kinetics experiments were based on the model that diffusion is the main mechanism of drug release. Therefore the dialysis bath was not well stirred and this contributed to a concentration gradient in the bath that may have affected measurements. Given that emulsion based drug delivery is being investigated for intravenous use, and because blood in the human body is a flow system, it would be interesting to conduct release kinetics experiments in the future with a well mixed dialysis bath to introduce convective mass transfer. This would eliminate the

concentration gradient observed in the bath and would perhaps be a more realistic drug release model.

It was observed during lidocaine release kinetics experiments that lidocaine encapsulated in an emulsion was released at a slower rate than in a solution of lidocaine alone. This is a promising result but due to the choice of  $10^{-4}$ M NaOH as the aqueous phase in all experiments, the results may not be quantitatively significant. The NaOH solution was chosen to fix the pH at approximately 10 because lidocaine is pH-sensitive. However, the NaOH solution was unstable and the pH could change significantly over the course of a day. Therefore, better pH control is needed through the use of buffers. While the use of the NaOH solution may have contributed to inaccurate measurements, we feel that the trends exhibited in the release kinetics experiments are indicative that there is a more controlled lidocaine release from an emulsion.

## Bibliography

- Brannon-Peppas, L. "Polymers in Controlled Drug Delivery." Medical Plastics and Biomaterials Magazine Nov (1997): 34. 30 Jan. 2006 <<http://www.devicelink.com/mpb/archive/97/11/003.html>>.
- Amersham Biosciences. "Dextran Data File." 9 Feb. 2006 <<http://www.dextran.nu/media/18-1153-41AA.pdf>>.
- Burguera, J., Burguera, M. Analytical applications of organized assemblies for on-line spectrometric determinations: present and future. J. Talanta 64; (2004) 1099-1108
- Chemical Heritage Foundation. "Allene Rosalind Jeanes." Women in Chemistry. 9 Feb. 2006 <[http://chemheritage.org/women\\_chemistry/food/jeanes.html](http://chemheritage.org/women_chemistry/food/jeanes.html)>.
- Correia, R., McElearney, K., Pinzon, P. Dextran C6 as a Surfactant for Oil in Water Emulsions. Worcester Polytechnic Institute, Worcester, MA (2005)
- Desmond, B., Savard, J., Shea, K. Drug Delivery Using Modified Dextran Polymers In Microemulsions. Worcester Polytechnic Institute, Worcester, MA (2003).
- Dumitriu, S. Polymeric Biomaterials. 2nd ed. New York: Marcel Dekker, Inc., 2001. 13 Feb. 2006 <<http://www.ebrary.com/corp/index.htm>>.
- Durand, A., E. Marie, E. Roteueau, M. Leonard, and E. Dellacherie. "Amphiphilic Polysaccharides: Useful Tools for the Preparation of Nanoparticles with Controlled Surface Characteristics." Langmuir 20 (2004): 6956-6963.
- Faigle, W. "Polymers in General." 1997. Hochschule für Druck und Medien, Stuttgart, Germany. 31 Jan. 2006 <[http://www.hdm-stuttgart.de/projekte/printing-inks/b\\_polym0.htm](http://www.hdm-stuttgart.de/projekte/printing-inks/b_polym0.htm)>.
- Gordon, W. L., comp. Polymers & Liquid Crystals. 1994. Case Western Reserve University. 26 Jan. 2006 <<http://plc.cwru.edu/tutorial/enhanced/main.htm>>.
- Hargreaves, T. "Surfactants: the ubiquitous amphiphiles." Chembytes e-zine. July 2003. Royal Society of Chemistry. 31 Jan. 2006 <[http://www.chemsoc.org/chembytes/ezine/2003/hargreaves\\_jul03.htm](http://www.chemsoc.org/chembytes/ezine/2003/hargreaves_jul03.htm)>.
- Manawanitjarern, W., Rogers, S. Polymer stabilized emulsions for drug delivery. Worcester Polytechnic Institute, Worcester, MA (2004)

- Martin, M. Surfactants and Polymers in Drug Delivery. New York: Marcel Dekker, Inc, 2002. Gordon Library eReader. 26 Jan. 2006 <<http://site.ebrary.com/lib/wpi>>.
- Rotureau, E., Christophe C., Edith D., and Alain D. "Neutral Polymeric Surfactants Derived from Dextran: A Study of Their Aqueous Solution Behavior." Macromolecular Chemistry and Physics 206 (2005): 2038-2046.
- Rotureau, E., M. Leonard, E. Dellacherie, and A. Durand. "Amphiphilic derivatives of dextran: Adsorption at air/water and oil/water interfaces." Journal of Colloid and Interface Science 279 (2004): 68-77.
- Rouzes, C., A. Durand, M. Leonard, and E. Dellacherie. "Surface Activity and Emulsification Properties of Hydrophobically Modified Dextrans." Journal of Colloid and Interface Science 253 (2002): 217-223.
- Rouzes, C., M. Leonard, A. Durand, and E. Dellacherie. "Influence of polymeric surfactants on the properties of drug-loaded PLA nanospheres." Colloids and Surfaces B: Biointerfaces 32 (2003): 125-135.
- Stevens, J., Mims, P., and Coles, N. Lipid Emulsions as Drug Delivery Systems. Fresenius Kabi Clayton L.P. 2003. 23 Feb. 2006 <<http://www.touchbriefings.com/pdf/17/ACF9CFB.pdf>>.
- Wikipedia. "Micelle." 16 Feb. 2006 <<http://en.wikipedia.org/wiki/Micelle>>.

## Glossary

Aggregation – collection: several things grouped together or considered as a whole

Amphiphilic – denotes a molecule combining *hydrophilic* and *hydrophobic* properties

Association Concentration ( $C^{ass}$ ) – upper concentration limit of the dilute domain for *amphiphilic* polymers

Coalescence – Liquid particles in suspension that unite to create particles of a greater volume

Colloid – a substance comprising very small, insoluble particles, usually 1 to 1000 nm in diameter, that are uniformly dispersed or suspended in a finely divided state throughout a continuous dispersion medium, not settling readily

Creaming – type of *emulsion* destabilization where droplets of the less dense component float to the top and form a separate layer

Critical Concentration (CC) – concentration above which no further decrease in *surface tension* is observed

Degree of Substitution – see *Substitution Ratio*

Dextran – a linear *polysaccharide* made of many glucose molecules joined into a long chain.

Differential Scanning Calorimetry (DSC) – an analytical method which measures the changes in the thermal properties of a material as a function of temperature

Droplet Surface Coverage ( $\Gamma$ ) – the amount of polymer coating the *emulsion*, reported in units of weight per unit surface area

Dynamic Light Scattering (DLC) - analytical technique used to determine the change in size and position of small suspended particles. It is particularly suited to determining small changes in mean diameter such as those due to adsorbed layers on the particle surface

Dynamic Surface Tension – measurement of *surface tension* values under conditions that are not at equilibrium (dynamic zone)

Emulsion – A mixture of two insoluble liquids such, as oil and water, consisting of droplets of one liquid dispersed throughout the other

Flocculation – The clumping together of smaller particles to form larger particles which drop out of suspension more quickly

Freeze-drying – (also known as *Lyophilization*) is a dehydration process typically used to preserve a perishable material, or to make the material more convenient for transport. Freeze drying works by freezing the material and then reducing the surrounding pressure to allow the frozen water in the material to sublime directly from the solid phase to gas

Huggins Coefficient ( $k_H$ ) – a parameter in the *Huggins Equation*

Huggins equation - The equation describing the dependence of the *reduced viscosity*,  $\eta_i/c$ , on the mass concentration of a polymer,  $c$ , for dilute polymer solutions of the form:  $\eta_i/c = [\eta] + k_H[\eta]^2c$  where  $k_H$  is the *Huggins coefficient* and  $[\eta]$  is the *intrinsic viscosity*.

Hydrophilic – Attracted to water. Having the property of mixing readily with water. Hydrophilic compounds are typically polar compounds, with charged or electronegative atoms

Hydrophobic – Repelled by water. Having the property of not mixing readily with water. Hydrophobic compounds are typically non-polar compounds, without charged or electronegative atoms, and often contains many CH bonds

Induction Period – The initial slow phase of a chemical reaction which later accelerates

Interfacial Tension – The *surface tension* at the surface separating two non-miscible liquids. The tangential force at the surface between two liquids, or a liquid and a solid, caused by the difference in attraction between the molecules of each phase. Expressed as a force per unit length or as an energy per unit area.

Intrinsic Viscosity ( $\eta$ ) – A measure of the capability of a polymer in solution to enhance the viscosity of the solution. The intrinsic viscosity number is defined as the limiting value of the specific viscosity/concentration ratio at zero concentration.

Lyophilization – see *Freeze-drying*

Oil Volume Ratio (C/V) – ratio of polymer concentration to oil volume dispersed in the aqueous phase

Ostwald Ripening – the process by which larger particles (or droplets for *emulsions*) grow at the expense of smaller ones due to the higher solubility of the smaller particles and to molecular diffusion through the continuous phase

“Overlap Concentration” ( $C^*$ ) – The concentration of a polymer in a solution at which the molecules begin to interpenetrate each other and become entangled. At this concentration there may be significant changes in properties such as sharp increases of *viscosity* and the mechanism of motion

Partition Coefficient ( $K_p$ ) – ratio of the solute concentration in the desired solvent to the solute concentration in the undesired solvent

Polyelectrolyte Effect – decrease in hydrodynamic volume with increasing electrolyte concentration. This is due to a decrease in electrostatic repulsion

Polysaccharide – A biological polymer composed of sugar subunits

Reconstitution – The process of adding liquid to a dry powder to make a new solution

Reduced viscosity - The ratio of the *relative viscosity increment* to the mass concentration of the polymer,  $c$ , i.e.  $\eta_i/c$ , where  $\eta_i$  is the relative viscosity increment.

Relative viscosity increment - The ratio of the difference between the viscosities of solution and solvent to the viscosity of the solvent, i.e.  $\eta_i = (\eta - \eta_s)/\eta_s$ , where  $\eta$  is the viscosity of the solution and  $\eta_s$  is the viscosity of the solvent.

Kinetics – The study of the rates of chemical reactions

Saccharide – an essential structural component of living cells and source of energy for animals; includes simple sugars with small molecules as well as macromolecular substances

Static Light Scattering (SLC) – analytical technique used for determining the structural information about the particles, including size, shape and molar mass

Steric – Steric effects are the interaction of molecules dictated by their shape and/or spatial relationships

Substitution Ratio – (also known as *Degree of Substitution*) the number of grafted *hydrophobic* groups per 100 glucopyranose units

Surfactant – A soluble chemical compound that reduces the surface tension between two liquids, usually an organic compound whose molecules contain a *hydrophilic* group at one end and a *hydrophobic* group at the other

Surface Tension ( $\gamma$ ) – The force that controls the shape of a liquid. Surface tension results from the force of cohesion between liquid molecules

Viscosity - resistance of a liquid to shear forces (and hence to flow)

# Appendix A: Equipment and Experimental Procedure

(Correia, et al. 2005)

## ***A.1 High Performance Particle Sizer (HPPS)***

Malvern Instruments Ltd., United Kingdom  
Microsoft Windows 2000 software

### **A.1.1 Software Set Up**

Before the emulsions were run in the HPPS machine it was necessary to create a Standard Operating Procedure (SOP) which is the method of measurement that was used during this investigation. Creating an SOP allows us to measure all the emulsions in the same way by setting pre-set parameters that will be stored in the file and that could be used later on without having to repeat the set up procedure.

To create and SOP, the HPPS software called Dispersion Technology Software program is opened and in the Configure menu **New SOP** is selected. Next the measurement type is chosen. For this investigation **Size** measurement was selected, but HPPS is able to measure not only this property but Protein Melting Point, Zeta Potential, Molecular Weight of the sample and trend.

After selecting the type of measurement a sample name must be selected, this will help later on to see the description of the sample being tested. General notes can also be included in this section; such as different concentrations used. It is important to check on the box that says **Show this page when the SOP is started...** since this will allow us to change the name of the emulsion if we need to and modify any comments we have made with previous samples. Then click **Next**.

In the next screen the type of cell or cuvette that will be used with this equipment must be specified since depending on the material that the cell is made of, the accuracy of the measurements can vary significantly. During this project a **DTS0012-Disposable sizing cuvette** was chosen. The following table summarizes the properties of this type of cell.

**Table 3: Choosing the correct (Size measurements) adapted from Zeta Nano Series User Manual, p 4.4**

	<b>Disposable Polystyrene (DTS0012)</b>
<b>Typical Solvent</b>	Water, Water/Ethanol
<b>Optical Quality</b>	Good to very good
<b>Minimum Sample Volume</b>	1mL
<b>Advantages</b>	Low cost Single use disposable (No cleaning necessary)
<b>Disadvantages</b>	Not resistant to organic solvents Unsuitable for use at high temperatures (Above 50°C)

Once this type of cell is chosen the software determines the conditions of measurement for that cell type, i.e. cell position.

After clicking on **Next**, the sample settings have to be specified. During this investigation only sample settings for size determination were set. The first step is to determine the material and dispersant properties. To do so, the **Dispersant** tab must be selected which provides us with a list of all the possible dispersants for that type of cell, such as decane, toluene and water among others. During this project, **Water** was selected as our dispersant material.

The next step was to set up the measurement properties. A temperature of 25°C was specified because our sample needed to be at room temperature during measurements in order to avoid any changes in particle size. The type of measurement duration was set to **Automatic** because as stated previously this will allow the equipment to perform the same test with all the samples, thus avoiding changes in how the measurement is done.

By setting the measurement duration to automatic the measurements were divided into a number of runs of at least 10 seconds in length. For accuracy of results, the number of measurements was set to **3** since this allowed us to confirm how well the solution was mixed after being diluted.

### **A.1.2 Sample Measurements**

Once the SOP file has been created and all the measurement properties for particle size have been set the HPPS was ready to take measurements. After turning the HPPS on it was important to let the machine stabilize for about 30 minutes before starting the first run since this was considered enough time for the machine to reach room temperature and provide more accurate results. To prepare the sample two or three drops of the emulsion were placed into the disposable cuvette. The sample was then diluted with MilliQ water. It was important to fill the cuvette at least 10mm from the bottom of the cell since the HPPS starts measurements 8mm from the bottom of the cuvette.

Once the sample was diluted the cell was placed into the particle sizer and it was left undisturbed for at least 10 minutes to let the sample settle and the dilution mix. Once this period of time has elapsed from the measure menu **Start SOP** is selected. This will bring up all the files that the program has. After selecting the SOP file name that was given previously, the sample was ready to be measured by pressing the **Start** key. The system starts the measurement by setting the number of runs and by attenuating the index. Once these parameters were set, the sample starts running.

While the sample is running it is possible to observe the quality of the sample or if there is dust in the sample. This can be easily seen in the **Count Rate** and the

**Correlation** tabs. It can be determined from the count rate if there is dust in the sample if there are sharp spikes in the plot that is displayed.

The quality of the sample is easily observed under the correlation tab since this provides a plot that helps to interpret any problems with the emulsion. Figure 20 is an example of how to differentiate between a contaminated sample and a normal one.

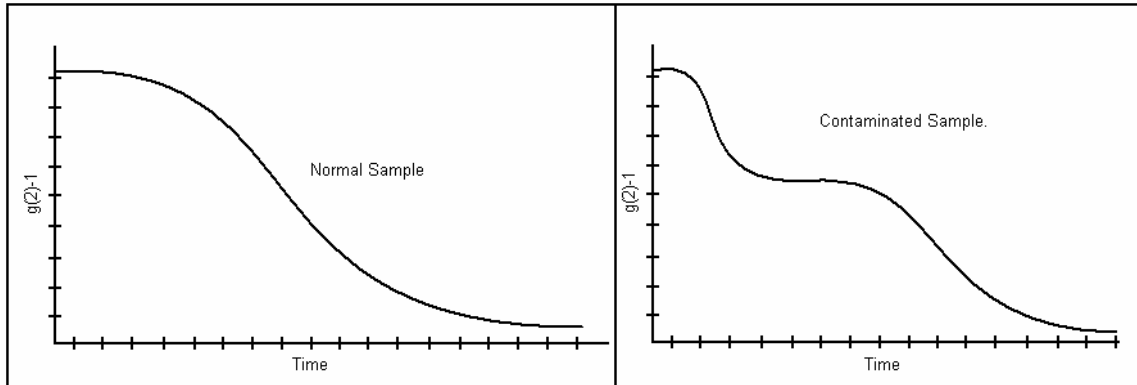

**Figure 20: Correlation Function**

Once the sample run is finished, results by intensity as well as by volume can be obtained. For accuracy during this project all the results reported are based by intensity. Figure 21 shows the equipment used to determine the average particle size of most of our emulsions.



**Figure 21: High Performance Particle Sizer**

## ***A.2 Emulsification***

Bioblock Scientific Vibracell  
Prolabo Adjusting Table

To prepare all the solutions a certain amount of Dextran C6 was added into a 100ml vial. MilliQ water or Phosphate buffer was added to the vial where a concentration of 5g/L was maintained. The solution was then placed on a Bioblock Stirrer at a speed of 350 rpm and it was left stirring overnight to ensure that the entire polymer dissolves in the continuous phase.

Once the dextran was dissolved, the emulsions were prepared by weighting 4mL of oil and placing it in a 50mL centrifuge tube along with approximately 6mL of water or buffer. A ratio of 1 to 6 weight of oil to weight of water or buffer was always kept. The mixture was vortexed for 1 minute and then it was placed in an ice bath where the tube is

being held by a rubber flask holder. Placing the centrifuge tube in this rubber stand guaranteed that the emulsion was stable during sonication.

The flask containing the emulsion was placed in the sonicator wooden cabinet. The sonication probe was then immersed into the emulsion being careful that the probe was at least halfway down the emulsion and that it did not touch the plastic tube.

The Vibracell box was then set up so the emulsification process would last 3 minutes. This was done by adjusting the time setting to 180 seconds. The active cycle was set to 50% which means that the probe will send sound waves to the emulsion for one second every two seconds. The power setting was set by turning the knob to 5 which represent a voltage of about 100W. Once all the settings were set the wooden cabinet door was closed and the **Marche** button was pressed. Figure 22 shows the Bioblock Scientific Vibracell sonicator used during this project.



**Figure 22: Bioblock Scientific Sonicator**

## **A.3 Centrifugation**

*Apparatus:*  
Jouan GR 20 22

The centrifuge is used to separate the desired product from the undesired solvent. The preparation of the centrifuge tubes is very important. There are six slots for the centrifuge tubes that were used. Opposite sides of the rotor must be equally balanced. In this specific centrifuge, the weight difference on opposite sides of the rotor must be within 50 mg of each other. If this weight difference limit is not obeyed, the machine can break.

Place the centrifuge tubes in the rotor with its respected equal weight centrifuge tubes on the opposite side of the rotor. Then with the hand wrench lightly secure the lid. Excessive force is not necessary. Then close the hood of the centrifuge. Next set up the program desired.

Programming:

Turn on the centrifuge with the switch located on the right side of the machine

Press 'Prog'

Output: "Numero Programme: \_ \_"

Press 20 then enter

Output: "Prog Numero 20 Exist"

Press enter

Output: "Rayon: \_97mm"

Press enter

Output: "Duree/Int? (1/0): 1"

Press enter

Output: "Duree: \_\_h\_\_min"

Enter desired length to centrifuge then press enter

Output: "Temperature: 25 C"

Enter desired temperature then press enter

Output: "Delta Temp: 0 C"

Press enter

Output: "Acceleration: \_"

Enter desired acceleration (1-9) then press enter

Output: "Frienage: \_"

Enter desired frienage (1-9) then press enter

Output: "Vit/NBG? (1/0): 1"

Press enter

Output: "Vitesse: \_\_\_\_\_ Tr/mn"

Enter desired revolutions per minute (up to 18000) then press enter

Output: "Ecrire Sous Le No: 20"

Press enter

Press start to begin program 20

Once the program has run through completion and the pressure inside the chamber returns to atmospheric pressure, the hood can be opened using the switch on the right side of the machine. Next remove the lid using the hand wrench. The centrifuge tubes can then be removed carefully and with as little agitation as possible. It is even suggested to extract the aqueous face while the tubes are at the centrifuge to stop the

agitation created when walking with the samples. Additional runs of the aqueous face may be needed to obtain the desired separation. Once finished turn off the machine.

Figure 23 shows the centrifuge apparatus used during this investigation.



**Figure 23: Centrifuge System**

## ***A.4 Freeze Drying***

Labcono Freeze Dry System/Freezone® 4.5  
Alcatel rotary pump

Once the emulsions were prepared a certain amount of Dextran T40 modified or unmodified was added in order to obtain a final ratio of 5 mg total Dextran per ml of solution. The solution was left shaken on a stirrer table overnight to ensure that all the Dextran that was added was dissolved in the emulsion. When the solution was completely dissolved the emulsions were placed in 5mL plastic centrifuge tubes were these were filled with 2.5 to 3mL of the emulsion. It was important to put no more than 3mL of solution into these tubes in case of overspilling the emulsion during freeze drying. About five or six holes were punched into the caps of the centrifuge tubes using a needle to allow air to flow out of the tubes during lyophilization.

Once all the tubes were sealed using the caps they were properly labeled and an elastic band was used to hold all the tubes together. Liquid nitrogen was then poured into a Styrofoam container and the tubes were then immersed in the container and then spun around to make sure that liquid nitrogen made contact with the emulsions through the tubes. The tubes were bathed in liquid nitrogen until the emulsions froze and a thin sheet of ice was seen around the tubes. The emulsions were then placed in a big glass container and attached to the Labcono Freeze Drying System. A paper towel was then folded and placed under the container for support.

The pump attached to the freeze drying system was turned on letting the vacuum system activated. The valve that connected the glass flask and the apparatus was then turned clockwise in a very slow motion until the motor pump made a distinct noise

indicating that the pressure in the system was increasing. The valve was turned until it was parallel with the top of the flask. The pump kept going until the pressure stabilized ceasing the noise and starting the drying process. The samples were left in the freeze drying system for a period of 48 hours where the sample had sufficient time to dry.

To remove the flask from the drying system the valve connecting the glass flask to the apparatus was turned counterclockwise where the pressure starts releasing and the flask was then removed from the system. The rotary pump as well as the freeze drying apparatus was then switched off.

The dried product was then scraped off the centrifuge tubes using a metal spatula and it was placed in a 20mL vial where it was reconstituted by adding a certain amount of MilliQ water and then analyzed.

#### **A.4.1 Lyophilization during Polymer Synthesis**

For the case of freeze drying during polymer synthesis, after centrifuging the solution containing the Dextran polymer, section 3.1.2. Recovery of Polymer due to Membrane Break, the solution is placed in a round bottom flask and then immersed in the liquid nitrogen bath. As with the emulsions the flask is spun around to allow the nitrogen to make contact with the solution. The flask is spun for a period of 5 to 7 minutes where the solution is frozen and ready to be dried. Figure 24 shows how the flask is spun and Figure 25 shows the freeze drying apparatus used during this investigation.



**Figure 24: Liquid Nitrogen Bath**



**Figure 25: Labcono Freeze Drying System**

## ***A.5 UV Spectroscopy***

UV-2101 PC Shimadzu 2nd Floor

Before running UV the computer was turned on as well as the UV spec. It was important to turn on the UV before opening the program. Once the program was opened, it would run a self check to ensure that the equipment was working properly. Once the check was complete you must go to the menu bar at the top and to configure and parameters (Control P). Once this menu was opened you would change the wavelengths to 500 nm and 190 nm and the speed to medium. The other settings were in default, which consisted of: measuring mode, Abs; Recording Range 0 to 2.5; Slit Width (nm) 1.0; and Sampling Interval Auto.

At this point samples were prepared. Make sure to wash the cuvettes before each run and remove and solutions from previous runs using a pipette to ensure that no droplets remained. The cuvettes were then washed using the new solution before adding the sample to be tested. Once the samples were prepared the reference was placed in the further back cell while the sample was placed in closer cell. Click on the start and allow the UV to run the spec. Once the spec was complete click on the "Go to WL" button and type in 262 for the absorbance of lidocaine. This function provided a non-steady answer therefore wait for the system to sit on one number before reading the absorbance at that wavelength.

If only one cuvette was available follow the same directions for set up but run the reference as a sample and leave air in the reference. After the spec was run use the "Go to WL" and again go to 262 nm. After the system leveled out at a specific value click on

the “Auto Zero”. This system would then subtract this value from all values obtained for each wavelength. Only use this procedure to obtain a spec of lidocaine. If any other peak is being investigated use “Go to WL” at that specific wavelength and auto zero using that value.

Figure 26 shows the UV spectrophotometer used during this investigation.



**Figure 26: UV Spectrophotometer**

## ***A.6 Dialysis Membrane***

The Spectra/Por membrane was used during the polymer synthesis as well as drug release kinetics testing. In order to use the membrane one must cut the desired length and place the membrane into a beaker filled with MilliQ water. This is done to ensure the purity of the membrane. After 15 minutes take a sample from the water bath and have it tested through UV spectroscopy to check that it is clean and that the membrane is usable. If it is clean the membrane can then be tied off at one end and the solution is added. After the solution is poured into the membrane the other end is tied off and the membrane is placed into the bath.

If however the water does not read 0 on the UV machine, the membrane needs to be placed in another MilliQ bath until such time that it does read zero. Repeat this procedure each time a membrane is used.

## Appendix B: Data

### *B.1 Emulsion Particle Size (No Lidocaine Present)*

#### 24 Hours

<b>Emulsion</b>	<b>Z-Avg (nm)</b>	<b>Polydispersity</b>	<b>Mean Count Rate (kcps)</b>
30g/L Trial 1	321.4	0.288	418
30g/L Trial 1	311.5	0.369	415
30g/L Trial 1	318.5	0.277	418
30g/L Trial 2	351.7	0.396	242
30g/L Trial 2	352.4	0.385	241
30g/L Trial 2	361.3	0.379	241
40g/L Trial 1	275.0	0.257	394
40g/L Trial 1	272.6	0.230	386
40g/L Trial 1	271.6	0.250	384
40g/L Trial 2	286.0	0.214	406
40g/L Trial 2	284.1	0.208	403
40g/L Trial 2	282.4	0.231	396

#### 48 Hours

<b>Emulsion</b>	<b>Z-Avg (nm)</b>	<b>Polydispersity</b>	<b>Mean Count Rate (kcps)</b>
30g/L Trial 1	357.6	0.300	401
30g/L Trial 1	355.6	0.276	397
30g/L Trial 1	343.3	0.290	397
30g/L Trial 2	346.2	0.348	220
30g/L Trial 2	351.9	0.372	223
30g/L Trial 2	349.2	0.383	225
40g/L Trial 1	284.0	0.238	318
40g/L Trial 1	282.7	0.257	317
40g/L Trial 1	284.7	0.241	313
40g/L Trial 2	284.3	0.294	365
40g/L Trial 2	287.7	0.296	377
40g/L Trial 2	293.8	0.261	375

### After Centrifuge Aging

<b>Emulsion</b>	<b>Z-Avg (nm)</b>	<b>Polydispersity</b>	<b>Mean Count Rate (kcps)</b>
30g/L Trial 1	464.9	0.326	234
30g/L Trial 1	445.1	0.322	236
30g/L Trial 1	450.3	0.366	240
40g/L Trial 1	283.9	0.243	402
40g/L Trial 1	279.2	0.259	411
40g/L Trial 1	280.3	0.254	407

### After Reconstitution

<b>Emulsion</b>	<b>Z-Avg (nm)</b>	<b>Polydispersity</b>	<b>Mean Count Rate (kcps)</b>
30g/L Trial 1	295.7	0.354	203
30g/L Trial 1	289.7	0.384	205
30g/L Trial 1	291.7	0.379	201
40g/L Trial 1	252.6	0.267	293
40g/L Trial 1	248.2	0.309	292
40g/L Trial 1	243.1	0.268	293

## ***B.2 Lidocaine Emulsion Particle Size***

### **24 Hours**

<b>Emulsion</b>	<b>Z-Avg (nm)</b>	<b>Polydispersity</b>	<b>Mean Count Rate (kcps)</b>
1	297.3	0.255	290
1	300.3	0.263	287
1	294.6	0.276	288
2	283.5	0.308	306
2	285.4	0.335	310
2	286.2	0.372	306

### **96 Hours**

<b>Emulsion</b>	<b>Z-Avg (nm)</b>	<b>Polydispersity</b>	<b>Mean Count Rate (kcps)</b>
1	343.7	0.311	300
1	338.0	0.340	296
1	333.7	0.327	298
2	332.3	0.343	399
2	326.8	0.357	393
2	320.9	0.364	384

### ***B.3 Release Kinetics: Lidocaine Only***

<b>Lidocaine Solution</b>
Extinction Coefficient = 1.8023
10mL Sample:
Lidocaine Conc = 2.977 g/L
60mL Dialysis Soln:
NaOH Soln Mass = 60.026g

<b>Time (min)</b>	<b>abs @262 nm</b>	<b>conc (g/L)</b>
0	0.0000	0.0000
20	0.0670	0.0372
35	0.0630	0.0350
50	0.0880	0.0488
65	0.1680	0.0932
80	0.2150	0.1193
95	0.1990	0.1104
110	0.2150	0.1193
125	0.1790	0.0993
140	0.1883	0.1045
155	0.1943	0.1078
170	0.2046	0.1135
185	0.2091	0.1160
200	0.2111	0.1171
215	0.2240	0.1243
230	0.2280	0.1265
245	0.2340	0.1298
260	0.2360	0.1309
275	0.2390	0.1326
290	0.2420	0.1343
305	0.2460	0.1365
320	0.2430	0.1348
335	0.2495	0.1384
350	0.2490	0.1382
365	0.2520	0.1398
380	0.2490	0.1382

## ***B.4 Release Kinetics: Lidocaine and DexC6***

<b>Lidocaine &amp; DexC6 Solution</b>
Extinction Coefficient = 1.8023
10mL Sample:
Lidocaine Conc = 3.007 g/L
DexC6 Conc = 40.003 g/L
60mL Dialysis Soln:
NaOH Soln Mass = 60.006g

<b>Time (min)</b>	<b>abs @262 nm</b>	<b>conc (g/L)</b>
0	0.0000	0.0000
30	0.1500	0.0832
60	0.2650	0.1470
75	0.3160	0.1753
90	0.2100	0.1165
105	0.2220	0.1232
120	0.2280	0.1265
135	0.2750	0.1526
155	0.3260	0.1809
175	0.3750	0.2081
190	0.3860	0.2142
205	0.3760	0.2086
235	0.3780	0.2097
265	0.4040	0.2242
295	0.3910	0.2169
330	0.4210	0.2336
365	0.4300	0.2386
395	0.4460	0.2475
425	0.4610	0.2558

## ***B.5 Release Kinetics: Lidocaine-Encapsulated Emulsion***

<b>Lidocaine-Encapsulated Emulsion</b>
Extinction Coefficient = 1.8023
10mL Sample:
Lidocaine Mass = 0.10029g
Octyldodecanol Mass = 3.22920g
DexC6 Mass = 0.24006g
NaOH Soln Mass = 5.97183g
200mL Dialysis Soln:
NaOH Soln Mass = 200.025g

<b>Time (min)</b>	<b>abs @262 nm</b>	<b>conc (g/L)</b>
0	0.0000	0.0000
30	0.1500	0.0832
60	0.2650	0.1470
75	0.3160	0.1753
90	0.2100	0.1165
105	0.2220	0.1232
120	0.2280	0.1265
135	0.2750	0.1526
155	0.3260	0.1809
175	0.3750	0.2081
190	0.3860	0.2142
205	0.3760	0.2086
235	0.3780	0.2097
265	0.4040	0.2242
295	0.3910	0.2169
330	0.4210	0.2336
365	0.4300	0.2386
395	0.4460	0.2475
425	0.4610	0.2558

## Appendix C: Sample Calculations

### C.1 Sample Calculations: NMR Analysis

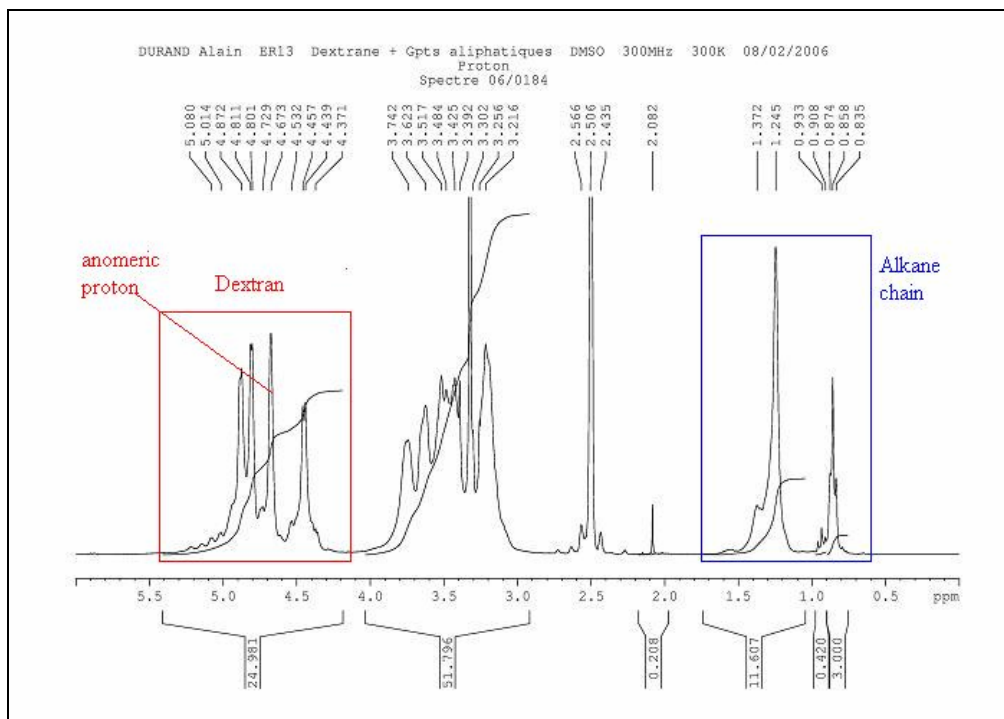

Determine approximate location of desired functional groups on NMR spectrum.

- Dextran monomer: 4.4 – 5.3 ppm
- Anomeric proton of dextran monomer: 4.7 ppm
- Alkane CH<sub>3</sub>: 0.9 ppm
- Alkane CH<sub>2</sub>: 1.3 ppm

Area of NMR peak represented by height of integral line

- Dextran monomer: 4.34 cm
- Anomeric proton: 1.0 cm
- Anomeric proton / all dextran monomer hydrogens: (1.0 cm / 4.34 cm) = 0.230

Area per hydrogen atom proportional to composition of sample

- Total dextran monomers: [(0.230) · 24.981] / 1 hydrogen = 5.76
- Alkane chains (substituted monomers): 3.420 / 3 hydrogens = 1.14

Substitution ratio = substituted monomers / total monomers

$$1.14 / 5.76 = 0.198 = 19.8\%$$

**DexC6 sample is approximately 20% substituted**

## C.2 Sample Calculations: Lidocaine Standard Curve

Raw Data:

Sample	Concentration (g Lidocaine/L)	Absorbance @ 262 nm	Absorbance @ 270.5nm
	0.00	0.000	0.000
1	0.99859	1.783	1.313
2	0.7433	1.334	0.985
3	0.49534	0.936	0.710
4	0.24984	0.450	0.332

Sample Calculations:

Beer's Law:  $A = \epsilon \cdot l \cdot C$

$l$  is length in cm of sample. For standard setup  $l = 1.0$

$A = \epsilon \cdot C$

Plot data points on (x,y) coordinate in (C,A) form:

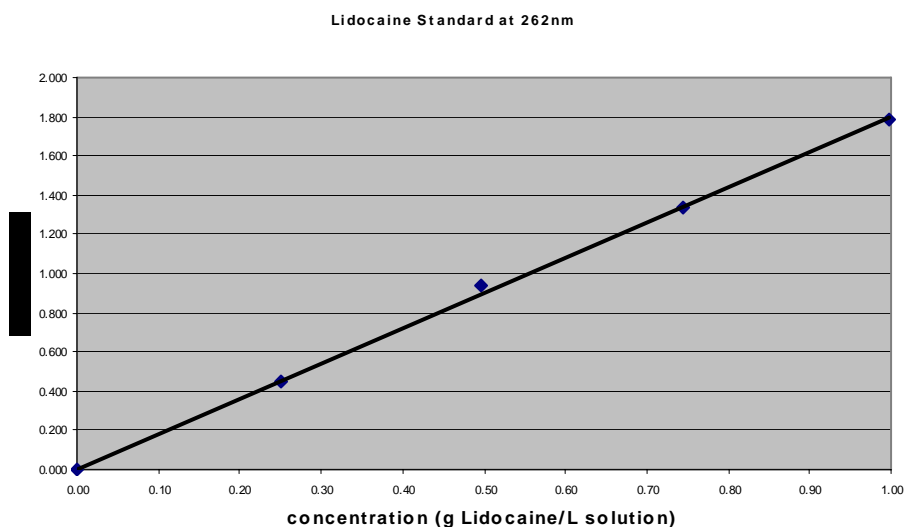

Find best fitting line to be  $y = 1.0823 x$

**Extinction coefficient ( $\epsilon$ ) = slope of line = 1.8023**

### **C.3 Sample Calculations: Saturated Lidocaine**

Prepare saturated lidocaine solution by mixing  $10^{-4}$  M NaOH and lidocaine solid. Allow to mix overnight and filter out excess lidocaine solids.

Dilute saturated solution. Aim for lidocaine conc  $\leq 1.0$  g/L so that Beer's Law may be applied.

Dilution: 1.02118 g Lido solution, add water until 7.06510 g total  
 $1.02118 / 7.06510 = 0.01445$  dilution factor

Take UV measurement and apply Beer's Law.

$\epsilon = 1.0823$  from previous calc

$$A = \epsilon \cdot l \cdot C$$

$$1.080 = 1.0823 \cdot (1.0) \cdot C$$

$C = 0.5993$  g/L  $\rightarrow$  this is less than 1.0 g/L, OK to use Beer's Law

Account for dilution:

$$C_1 V_1 = C_2 V_2$$

$$(0.5993)(7.06510) = C_2 (1.02118)$$

$$C_2 = 4.147 \text{ g/L}$$

**Saturated lidocaine solution concentration = 4.147 g/L**