

High Efficiency Coolant Nozzle Design for Abrasive Wire Wafer Slicing

A Major Qualifying Project Report:

submitted to the Faculty

of the

WORCESTER POLYTECHNIC INSTITUTE

in partial fulfillment of the requirements for the

Degree of Bachelor of Science

by

Michael Demers

Ryan Lehrmitt

Robert Pantalone

Date: April 28, 2008

Approved:

Professor Yiming Rong

This report represents the work of one or more WPI undergraduate students submitted to the faculty as evidence of completion of a degree requirement. WPI routinely publishes these reports on its web site without editorial or peer review.

Abstract

Sufficient coolant systems are vital when utilizing diamond wire slicing in the production of silicon wafers. Based on provided design parameters, multiple nozzles have been designed for Saint Gobain to use in their new abrasive diamond wire wafer-slicing machine. Each design has been analyzed using three-dimensional CFD simulation in order to obtain flow characteristics and determine the most effective design. This final design was fabricated at WPI as well as tested in the Saint Gobain testing laboratory.

Table of Contents

Problem Statement	6
Introduction	6
Background	7
SAINT-GOBAIN	7
SILICON WAFERS	10
GRINDING	11
WIRE SLICING	12
DIAMOND WIRE SLICING	14
COOLANT	15
Methodology	16
NOZZLE DESIGN	16
TESTING	18
Phase 1	18
Phase 2	20
Phase 3	26
MACHINING	31
Results	38
Conclusion	40
WORKS CITED	42

Table of Figures

Figure 1: World Standings in each sector (Saint Gobain)	8
Figure 2: Silicon Wafers (Silicon Valley Microelectronics 2008)	11
Figure 3: Conceptual Wire Saw Slicing set up (Kao)	13
Figure 4: SEM Micrograph of Diamond Wire (Hardin 2004)	14
Figure 5: Traditional and Improved Nozzle Design (Leblanc-Shoemaker 2007)	17
Figure 6: Equations used for Calculations (Fox 237 2006)	18
Figure 7: CFD Simulation Round 1	19
Figure 8: Tubing attached to nozzle.....	20
Figure 9: Nozzle Design with Tube Insertion from Top.....	21
Figure 10: Nozzle Design with Tube Insertion from Side	22
Figure 11: Reservoir Nozzle Design with Tube Insertion from Top	23
Figure 12: Reservoir Nozzle Design with Tube Insertion from Side.....	24
Figure 13: Velocity vs. Distance (Discarded Design)	25
Figure 14: Velocity vs. Distance (Highly-Ranked Design).....	25
Figure 15: Coolant tube fitting.....	26
Figure 16: Nozzle with reservoir and elbow fitting.....	27
Figure 17: Velocity of water at the plane 1.5 cm away from the nozzle	28
Figure 18: Nozzle with reservoir and straight fitting	28
Figure 19: Velocity of water at the plane 1.5 cm away from the nozzle	29
Figure 20: Nozzle with blended reservoir and elbow fitting and corresponding velocity at 1.5cm	30
Figure 21: Flow Chart of Ideas of Machining the Nozzle	32
Figure 22: Nozzle Hollowed out from Behind	33
Figure 23: Nozzle Hollowed out from the Side	34

Figure 24: Nozzle Cut in Half and Welded back Together 35

Figure 25: Flow Chart of Ideas of Machining the Reservoir..... 36

Figure 26: Nozzle Fits into Reservoir..... 37

Figure 27: Final Product 38

Figure 28: Parameters Met During Testing..... 39

Figure 29: Linearity of Flow over 6 cm..... 40

Problem Statement

Saint-Gobain is in the process of developing an ingot-slicing machine that utilizes diamond wire to cut silicon ingots into thin sections. They need a coolant system in order to provide lubrication, as well as to remove swarf material and maintain suitable temperatures within the work piece. This project deals with designing, testing, and implementing an adequate coolant system in order to aid Saint-Gobain in their process.

Introduction

The purpose of this project is to design an efficient coolant system for Saint-Gobain to utilize in their new diamond wire wafer slicing machine. This machine does not yet have any modes of applying coolant to the slicing zone. Competing wire slicing processes utilize a plain wire along with slurry with SiC or Al₂O₃ abrasive grains. Saint-Gobain Abrasives' wire has diamond abrasives plated onto a core wire. Coolant is desired, as it will lead to increased performance and product quality. The coolant application system is of chief concern to this project. The components in need of design include the nozzle, piping, attachments within the machine frame, etc. The question of nozzle geometry, coolant pressure, velocity and direction will be explored. These parameters depend on factors such as wire speed, direction of wire, kerf width (cut thickness) and size of the work piece.

The coolant nozzle and other components will be incorporated into the machine assembly onto the sub-assembly that holds the diamond wire spindles. The nozzle must be located and oriented within the assembly such that the stream provides optimal coolant delivery to the slicing zone. The coolant system has been designed and analyzed using computational fluid dynamics analysis. Interpreting this analysis, in addition to testing, a coolant system has been developed.

Addressing these problems will yield an effective coolant system design that Saint-Gobain can integrate with its diamond wire slicing process.

Background

SAINT-GOBAIN

Saint-Gobain is a multi-billion dollar company that transforms raw materials into products to be used in the everyday lives of people across the world. Saint-Gobain operates in 54 countries worldwide, and is one of the world's hundred leading industrial corporations. The company was created in 1665 as part of a plan devised by Louis XIV and Colbert to restore the French economy. In the 17th century, thanks to the invention of glassware casting, Saint-Gobain established a near monopoly in glass production. In the 19th century, Saint-Gobain crossed the French borders and set up glass production on a European basis. The company established units in Germany in 1857, Italy in 1889 and Spain in 1904. They also opened their first glass sales depot in the United States in New York during 1831. In 1970, Saint-Gobain merged with Pont-à-Mousson, the world leader in cast iron piping. This allowed them to become a producer of materials and capital goods geared to the global dimension of its markets. Then they acquired Norton Company in 1990 and Ball Foster Glass in 1995, expanding their market much further than had been expected. The company Poliet was also acquired in 1996, completing their expertise in distribution.

Saint-Gobain has many different divisions and business sectors spread throughout the world. They are among the world leaders in each of their business sectors. They provide the glass for 50% of all cars in Europe, and manufacture 30 billion glass bottles a year. One impressive achievement in their glass production sector is that they supplied all the glass for the

Louvre Pyramid. Saint-Gobain also insulates 1/5 of all homes in the United States, and manufactures the crystals used in airport security detectors and medical diagnosis. The figure below shows how Saint-Gobain ranks in the world in each of its sectors.

• SAINT-GOBAIN IS AMONG THE WORLD LEADERS IN EACH OF ITS BUSINESS SECTORS	
<u>FLAT GLASS</u>	N°1 in Europe N°3 worldwide
<u>ABRASIVES</u>	N°1 worldwide
<u>CERAMICS AND PLASTICS</u>	N°1 worldwide for thermal and mechanical applications
<u>REINFORCEMENT</u>	N°1 worldwide
<u>INSULATION</u>	N°1 worldwide
<u>GYPSUM</u>	N°1 worldwide
<u>PIPE</u>	N°1 worldwide in cast iron pipe
<u>INDUSTRIAL MORTARS</u>	N°1 worldwide in wall coatings and glues for tiling
<u>EXTERIOR PRODUCTS</u>	N°1 in US for sidings N°3 in US for roofing products
<u>BUILDING DISTRIBUTION</u>	N°1 worldwide in tiles distribution N°1 in Europe in building materials distribution
<u>PACKAGING</u>	N°1 in Europe N°2 worldwide

Figure 1: World Standings in each sector (Saint Gobain)

The abrasives sector will be focused on most because this sector is most pertinent to the project at hand. They are the world leader in manufacturing of abrasives and hold a strong presence in the USA, as well as throughout Europe, Asia and Latin America. Abrasives are used for cutting, grinding and polishing which makes them a vital aspect of manufacturing industries.

From this figure, it can be seen that Saint-Gobain is ranked number one worldwide in abrasives. They have three major types or families of abrasives: bonded abrasives, coated abrasives, and superabrasives.

Bonded abrasives consist of precision and fine grinding wheels. They are synthetic abrasive grains that are bonded into a solid form. This usually takes place in the shape of a wheel or disc. Saint-Gobain produces more than 250,000 types of grinding wheels with diameters ranging from just two millimeters up to two full meters. The synthetic wheels are made of clay-based binder for precision grinding, sharpening and forming in many industries such as automotive, aerospace and machine tools. The organic wheels are made with rubber or plastic bonds for cutting and forming in markets such as primary metals, welding, and metal fabrications.

Coated abrasives are more commonly referred to as sandpaper even though they are not made with sand, and usually are not backed with paper. They are formed by gluing organic and synthetic abrasive grains. They are manufactured in large rolls then cut into different shapes such as belts, discs, and rolls for surface treatment and polishing. These are commonly used in markets such as furniture, lumber, cabinet, boat, automotive, welding, jewelry, among many others.

Superabrasives are grinding and cutting wheels, tools, slurries, belts, etc. that incorporate diamond and cubic boron nitride (CBN) abrasives. They are made of resin, metal, or plated bonds. These are used in precision grinding in many markets such as automotive, architectural or crystal glass. They are used to shape engine and transmission components such as crankshafts

and cams, and used in slicing silicon wafers. These abrasives are present within this scope of this project.

The Saint-Gobain division in Worcester, MA, is the main sector for abrasives in the USA. In 1966, Norton Company, which was a manufacturing conglomerate with their headquarters at Worcester, MA, acquired U.S. Stoneware and Chamberlain Engineering Corp. In 1990, Norton Company was acquired by Saint-Gobain, who took over this headquarters and it still stands in the same place today. This location is part of Saint-Gobain's abrasive sector, and manufactures abrasives and abrasive products.

SILICON WAFERS

The commercial product of interest in this project is the silicon wafer. This thin slice of silicon is the base for semiconductors and microchips for use in electronics. "Silicon is a gray, brittle, tetravalent, nonmetallic chemical element. It makes up 27.8% of the earth's crust and next to Oxygen; it is the most abundant element in nature." (Silicon Valley Microelectronics 2008)

The silicon is often doped using various chemicals to achieve the desired semiconducting properties. A cutting process slices a large, single crystal silicon ingot into individual wafers. "The silicon wafers are etched with millions of tiny transistors 100 times smaller than a human hair. These semiconductors manage data by controlling the flow of electrical current to make words, numbers, sounds, images and colors... Applications can be found in commonplace items like computers, telecommunications and televisions, as well as in more advanced applications like microwave transmissions, laser switching systems, medical diagnostic and treatment equipment, defense systems and the NASA space shuttle."(Silicon Valley Microelectronics 2008)

The finished silicon wafers have thicknesses on the scale of tenths of a millimeter. After being sliced, the wafers go through various grinding and polishing processes to remove any cracks or

imperfections created during the slicing process. This project is mainly concerned with the slicing performance. Improvements in sliced silicon quality could lead to less grinding processes and less material waste. A silicon ingot can be seen sliced into several wafers in Figure 2.

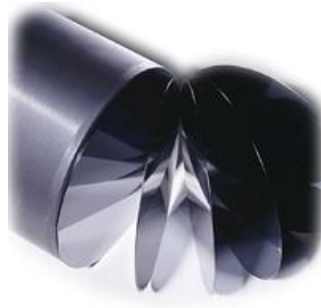

Figure 2: Silicon Wafers (Silicon Valley Microelectronics 2008)

GRINDING

Throughout the world, companies are using many different types of manufacturing processes. As described by Britannica Encyclopedia, manufacturing is the “fabrication or assembly of components into finished products” (Britannica 2008). Saint-Gobain is one of the world leaders in manufacturing products all over the world, as was shown in Figure 1. When a product is manufactured, many different steps usually have to be taken before the product is completely finalized. One of the major steps that have to occur in such a process is that material stock has to be cut or modified. There are multiple techniques for material removal. Grinding is one of the most common methods. In regards to the entire process for transforming material into a final product, the grinding part is usually done towards the end of this process. Grinding can achieve tighter tolerances and higher surface quality than other processes such as casting or cutting processes, so the product is generally ground after to remove excess material with higher precision. A company might grind a product that might not lend itself well to other

manufacturing methods. Examples of these materials include hardened steels, ceramics, and glass.

Grinding can result in wear of the grinding medium as well as high temperatures due to friction between the grinding wheel and work piece. To keep the temperature down as well as preserve the condition of the grinding wheel, coolant is commonly introduced into the grinding and cutting processes. The most widely used coolants are water based soluble oils (Koshal 1993). To maintain an efficient process, it is very necessary to control the coolant application as well as monitor the wheel wear. Without the application of, there could be substantial grinding damage on the part.

WIRE SLICING

Along with grinding, another process used to cut materials is using a wire saw. Although the grinding process is efficient with most products, it is not the most ideal process to use to cut silicon wafers, which are referred to above in the previous sections. If the ingot diameters were six inches or less, then an ID (inner diameter) saw would be used to cut the wafers. However, if the diameters of the ingots were larger than six inches, wire saws are used to cut the ingots at the desired lengths. Instead of using a grinding wheel to make modifications or cuts, this process uses a single strand of thin stainless wire (175 micrometers in diameter) that runs from feed reel to another feed reel. Due to the thickness of the wire, the kerf loss is kept at a minimum. An example of this process can be seen in Figure 3.

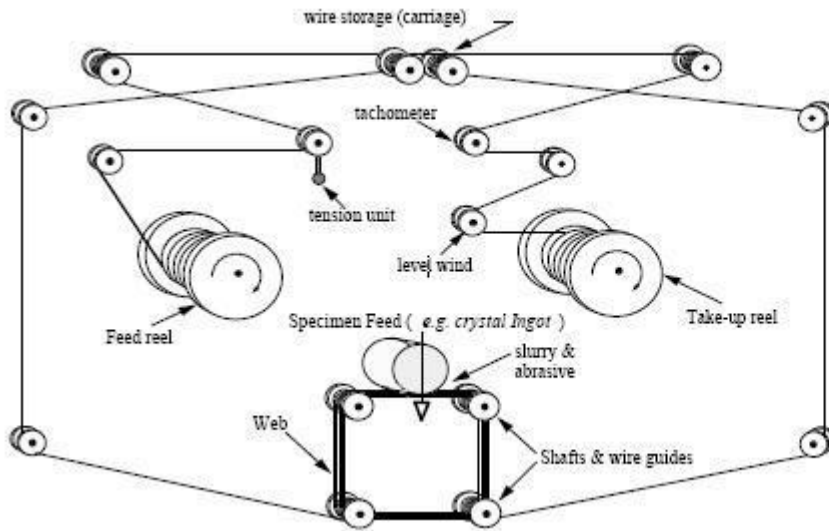

Abrasive slurry:

- SiC and diamond are most commonly used abrasives
- slurry also acts as coolant

Wire material:

- stainless steel is generally used
- typical diameter: 150-300 μm

Specimen:

- can be fed from 4 sides of the web simultaneously

Figure 3: Conceptual Wire Saw Slicing set up (Kao)

With regard to the wafers, the wire slicing process “produces less depth of damage and more uniform surfaces than a grinding process would,” which in turn results in lower residual stresses in the cut wafers (Kao). This is a very important result because high stresses tend to lead to a higher probability of the thin wafers breaking during both the cutting process and the handling process after they have been cut. Therefore, the lower stresses make the cut wafers easier to handle without breaking and to manufacture more homogeneous wafers in the process. Another advantage of using the wire slicing instead of grinding or some other cutting processes, is that the wire slicing uses “much less brute force” during the cutting of the wafers, which leads to a greater probability of more efficient cuts of the wafers (Kao).

Similar to the grinding process, the cutting and grinding equipment wears down over time. In order to help maintain the wire in this process, a watery mixture of an insoluble matter called slurry is used to coat the wire. By coating the wire with slurry, companies are able to help preserve the wear and tear of production. However, unlike the grinding process where a coolant

is necessary to be applied to the wheel, the wire slicing process does not need an extra coolant: the slurry on the wire also acts as a coolant. Unfortunately, slurry is not the cheapest material in the world. In addition to being costly to produce, after the slurry is used, it has to be collected and then disposed of. A major disadvantage of this process is the extra expense that has to be taken into account due to the slurry. In addition, because the wire is coated with slurry, the cutting speed of the wire is slow. Even though the wire is coated with slurry, there is still wire wear that occurs and can cause deformation in the cuts of the wafers.

DIAMOND WIRE SLICING

The practice of diamond wire cutting and slicing involves the use of a wire impregnated with diamonds. Diamonds are of course a choice abrasive due to their hardness. Diamond wire can be used on a variety of materials, ranging from concrete to the materials concerning this report, sapphire, silicon, and glass. A micrograph showing a segment of diamond wire can be seen in Figure 4. The protruding crystals that actively do the cutting are quite evident.

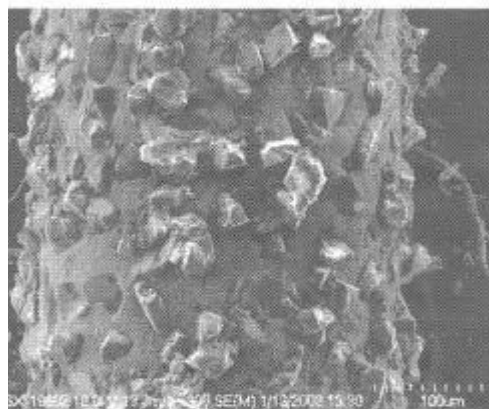

Figure 4: SEM Micrograph of Diamond Wire (Hardin 2004)

The use of diamond-impregnated wire for slicing is quite attractive, especially when dealing with expensive materials. The kerf width, when using diamond wire, can be as low as 155 microns (Diamond Wire Technology 2008). This low kerf leads to less wasted material. Also, because the diamond wire slicing process does not require the use of “hazardous waste slurry,” the wire can be maintained at a faster cutting speed, and it eliminates the cost to produce slurry as well as dispose of it (Hardin 2004). When dealing with expensive materials such as sapphire and silicon, it is quite desirable to keep waste to a minimum as it allows for more of the material stock to be used, and hence, make more product from less material.

Along with the quality of low-kerf cuts, “diamond wire combined with tangential cutting allows cut times 4 times faster than slurry with better parallelism of parts and TTV” (Diamond Wire Technology 2008). This allows for increased productivity when using diamond wire. The considerable product quality and productivity of diamond wire can potentially lower production costs of silicon wafers and other manufactured goods.

COOLANT

Coolant is commonly added to the cutting zone during material removal process. Friction between the tool and the work piece creates heat, which is detrimental to surface quality of the part, as well as tool life. “In cutting and grinding processes fluids are used both as coolants and lubricants, often at the same time. The effects that fluid use yields include: improved tool life and surface finish, reduced forces and energy consumption, reduction of thermal distortion, washing away chips, and protection from environmental corrosion.” (Leblanc-Shoemaker 2007)

Water can be used effectively as a coolant, or several purpose-made coolants and lubricants are available as additives that further increase performance. Innovative Organics, a

sister company of Saint-Gobain, produces a variety of coolants, slurries, and cleaners for specific applications. Their AmberCut™ product line is particular of interest. This is a line of various coolants with different chemical contents depending on application. Innovative Organic's Ambercut DWS 35 is one possibility for application to the diamondwire slicing machine (Innovative Organics 2008).

Methodology

NOZZLE DESIGN

Through extensive research of widely accepted and used nozzles in the manufacturing world as well as in the previous testing and research of previous projects, we were able to determine the most effective nozzle design. This nozzle design can be seen in Figure 5 as the "Improved Nozzle." This nozzle will produce the most uniform and effective coolant flow. The shape of the nozzle allows the coolant flow to gradually reduce in shape until it can exit through the outlet opening, D_r . However, in the "traditional nozzle", it can be seen that the coolant would not flow very smoothly because of the sharp corners and shape of the nozzle. The circular areas in the "traditional nozzle" represent the eddy zones that the coolant would create when it flowed through the nozzle and then recycled itself back into the the main stream of the flow. This would create a problem of efficiently dispensing the coolant out of the outlet opening. Ideally, the best nozzle design would not have any eddy zones; however, this is a very difficult task to achieve. The smallest wrong shape may force the flow to go against the normal flow of the coolant.

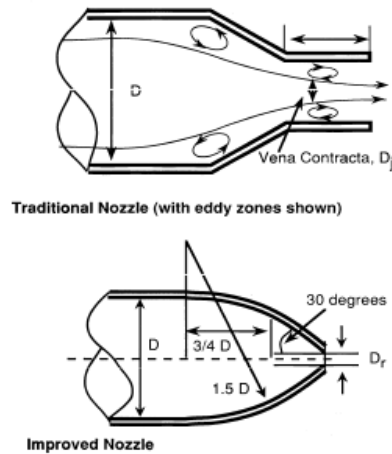

Figure 5: Traditional and Improved Nozzle Design (Leblanc-Shoemaker 2007)

Using given values, as well as assumed values, calculations were made in order to determine the ideal geometry for the design of the nozzle. Multiple nozzles have been designed thusfar in order to achieve this goal of obtaining the most efficient design. On top of designing the nozzle, it was realized through trial and error that even changing the positioning of the tygon tubing and where the tubing meets the nozzle (from the back, on the top, etc.) changes the flow properties substantially. Given values that cannot be changed were the foundation of the calculations. The outlet velocity of the nozzle must be atleast 15 m/s because this is the feed rate of the wire on the machine. The inlet pressure of three bar is an absolute pressure that cannot change, and the outlet pressure of one bar cannot be changed. Using these values and equations such as Bernoulli's Equation and the Conservation of Mass, values were obtained for the geometry of the nozzle, as well as the expected flow properties.

<p><u>Bernoulli's Equation</u></p> $\frac{P_1}{\rho} + \frac{V_1^2}{2} + g \cdot z_1 = \frac{P_2}{\rho} + \frac{V_2^2}{2} + g \cdot z_2$	<p><u>Conservation of Mass</u></p> $m'_1 = m'_2$ $A_1 \cdot V_1 = A_2 \cdot V_2$
--	--

Figure 6: Equations used for Calculations (Fox 237 2006)

TESTING

Many different CAD models have been assembled of the different nozzle designs, including a reservoir on some as well as using different positioning for the tubing. Some models have been tested using the software Ansys, in order to test flow characteristics. These characteristics include outlet velocity, coolant flow through the nozzle, the volume fraction of water to air, and the cohesiveness of the coolant flow out of the nozzle. This testing will help determine the most efficient design. By using the CFD simulation on Ansys, we can test the different nozzle designs without actually having to machine the parts.

Phase 1

In the first phase of testing, our group tested the initial design was tested using the Ansys, which proved to be an efficient application in helping select the best design. The first phase of testing was an initial trial run for future testing. It showed our group a great deal about our design and what we needed to improve. Unfortunately, this test was not entirely accurate because a flow rate of five gallons per minute was used; however, since then, the flow rate has been changed. Nonetheless, the program pointed out that the coolant traveling through the tubing was very turbulent and there were eddy zones in the streamline figure, shown in Figure 7.

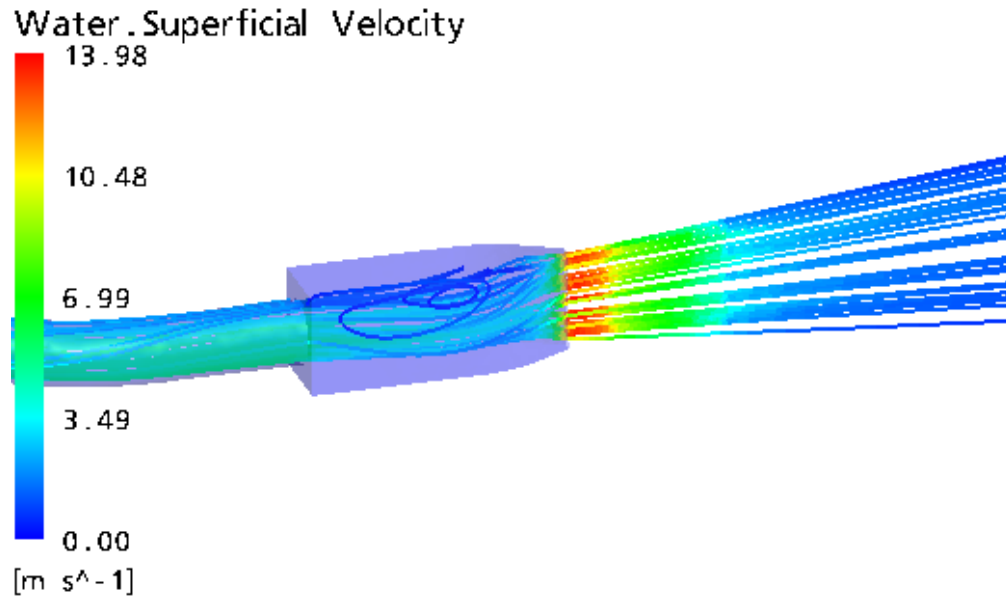

Figure 7: CFD Simulation Round 1

From Figure 7, one can see that the flow was not very uniform inside of the nozzle. The greenish colored liquid represented the water-based coolant flowing through the nozzle from the tube. However, the blue circular shapes represent the eddy zones inside of the nozzle. Although there are eddy zones inside of the nozzle, our group was confident that the nozzle design would work, and that the trajectory of the tubing leading into the nozzle contributed to the turbulence in the nozzle. From this simulation, our group understood how important the shape of the tube would be. Before this simulation, our group did not realize how the trajectory of the tube would affect the actual flow through the nozzle. The trajectory of the tube used in this simulation was arbitrary; being that our group was uncertain of the exact shape of the tube would really be in the final design. The arbitrary trajectory of the tubing can be seen in Figure 8.

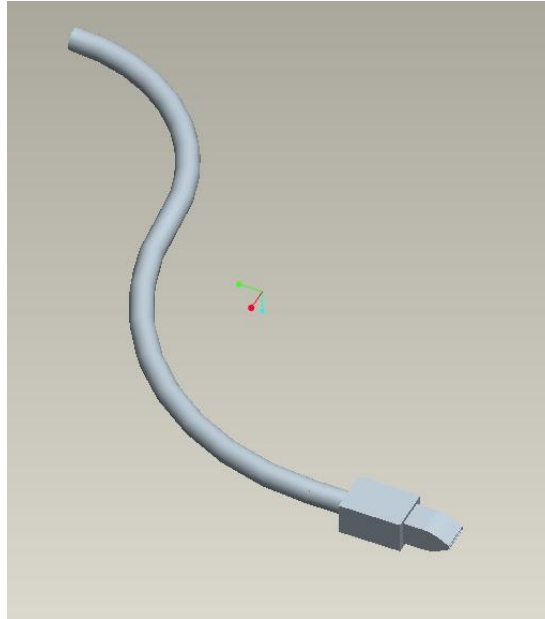

Figure 8: Tubing attached to nozzle

To eliminate any uncertainty that goes along with the trajectory of the tubing, the next simulation was done without the extra tubing because at this point in the process, the exact shape and placement of the tubing was undetermined. An exit velocity of 15 m/s was the ideal minimum value to obtain, when in reality the simulation showed that the design would only reach a velocity of 22 m/s.

Phase 2

For the next round of testing, our group had to make specific modifications to the nozzle design. These modifications were based off of the results from the previous phase of testing as well as incorporating changes made by our sponsor, Saint Gobain. The first modification made was eliminating the trajectory of the tube. Through the first phase, our group realized how much the tube trajectory affected the turbulence in the nozzle as well as the flow exiting the nozzle. Because the actual shape of the tube was unknown, our group felt it was unnecessary when

completing future tests on the nozzle with CFD simulation to incorporate the tube shape. Even though our group acknowledged that other factors may influence the resulting flow characteristics, at this time they were considered to be negligible to help focus primarily on the internal geometry of the nozzle. For this reason, the nozzle design included where the tube would be inserted into the nozzle and not the tube. For this reason, the design of the nozzle for this phase did not include the entire tubing but just the section to which the tubing would attach to the nozzle.

Another modification dealt with the placement of where the tubing would attach to the nozzle. After the first phase, our group learned of the limited amount of space that was available to be used for the nozzle with the SGA Wire Slicing Machine. Even though our group did not test the nozzle with the tubing attached to it, our group still had to consider how the nozzle would fit into the actual machine with the limited amount of space. Therefore, after finding out that there was a space constraint for the nozzles, our group realized that the tube could not be inserted into the back of the nozzle, because the tubing could potentially interfere with the wafers. Therefore, in this phase, our group attempted having the tube insertion from the top and from the side of the nozzle. These new tube placements on the nozzle can be seen in Figures 9 and 10.

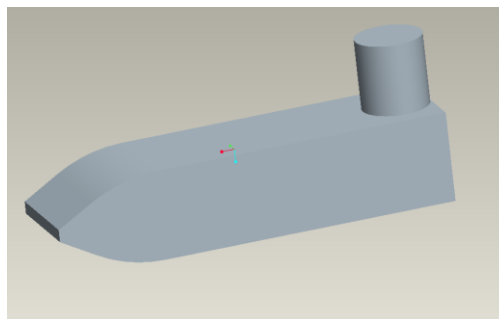

Figure 9: Nozzle Design with Tube Insertion from Top

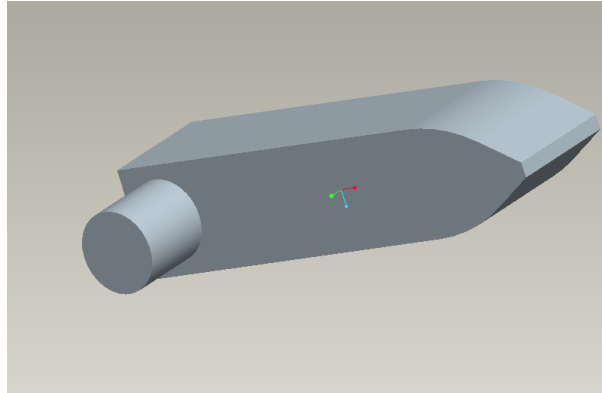

Figure 10: Nozzle Design with Tube Insertion from Side

Due to changes with Saint Gobain's SGA Wire Slicing Machine, there were a few mathematical changes that had to be integrated into our nozzle design. Because Saint Gobain was not going to use the five gallons per minute pump, our group had to solve for an inlet velocity of coolant flowing into the nozzle that would provide the necessary outlet velocity and exit nozzle height. Our group could solve for the necessary inlet velocity because the coolant flow could be adjusted to fit whatever was needed to ensure the desired outlet velocity. The expected inlet velocity has been determined to be 28.11 m/s, with an outlet velocity of 30 m/s. Originally, when using 15 m/s as the outlet velocity, which was determined from the wire feed rate, the calculations were not working out as planned. It was found that using a larger outlet velocity of 30 m/s resulted in better flow characteristics and a more ideal geometry in the nozzle. Using these numbers the nozzle inlet area was found to be $7.917 \times 10^{-5} \text{ m}^2$, and the nozzle outlet area to be $7.419 \times 10^{-5} \text{ m}^2$. The flow rate was determined to be 3.528 gal/ min. These numbers were subject to change, but for the moment have proved to be the most efficient values for achieving the proper flow. These calculations can be seen in Appendix A.

In order to justify our results from the CFD simulation in selecting the appropriate nozzle design, our group had to have more than one type of nozzle to compare. For this reason, our group researched past MQP reports and found another type of nozzle that our group could use for comparison. From Leblanc-Shoemaker and Melendez's report, our group incorporated the idea of a reservoir into the initial nozzle design from phase one. Even though the previous MQP group utilized this concept, our group completely redesigned the reservoir to accommodate the initial designs from Figures 9 and 10. Our group utilized this new reservoir nozzle design into phase two CFD simulations. To stay consistent with the tube insertion placement from the initial design, our group also used two reservoir designs in the simulations: one with the tube insertion from the top and one with the tube insertion to the side. These designs can be seen in Figures 11 and 12.

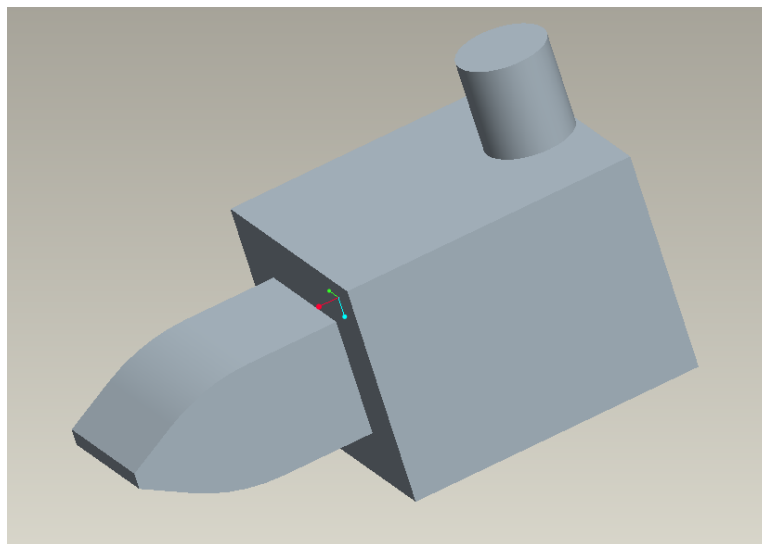

Figure 11: Reservoir Nozzle Design with Tube Insertion from Top

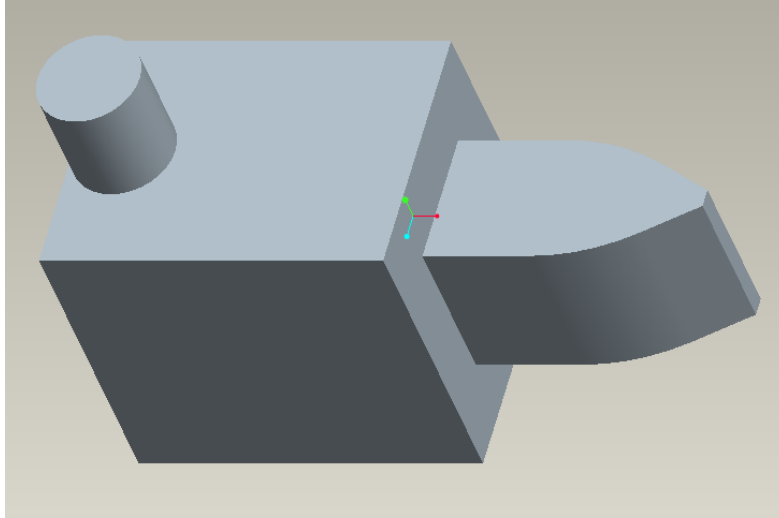

Figure 12: Reservoir Nozzle Design with Tube Insertion from Side

From the CFD results cases 1 and 4 proved to produce the best flow out of the nozzle. The streamline figures were analyzed and critiqued, and then improvements were suggested for the design of the nozzle. One suggestion was to round the edge opposite of where the tube is inserted so that the flow of the coolant has a smoother transition into the nozzle and does not hit a sharp angle. Another suggestion was to angle the tube fitting backwards so that the coolant would flow in at the same angle as the edge previously discussed. The figure below depicts the volume fraction of one of the nozzle designs, from the CFD simulation.

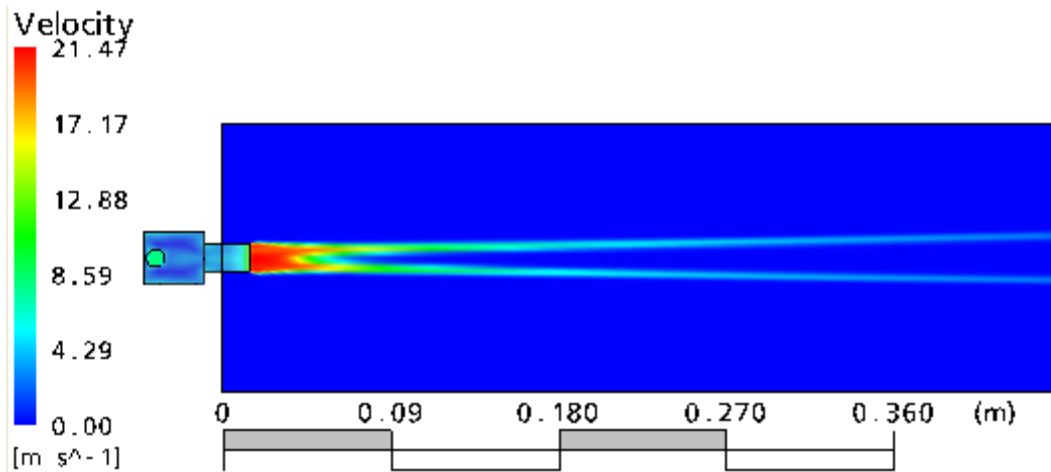

Figure 13: Velocity vs. Distance (Discarded Design)

When looking at this figure it becomes evident that this is not a flow characteristic that is ideal for a nozzle. The streamline splits down the middle and goes off at a very low velocity. This is an example of a design that was discarded because of the CFD simulation. The following figure depicts the design from the CFD simulations that produced the most efficient flow.

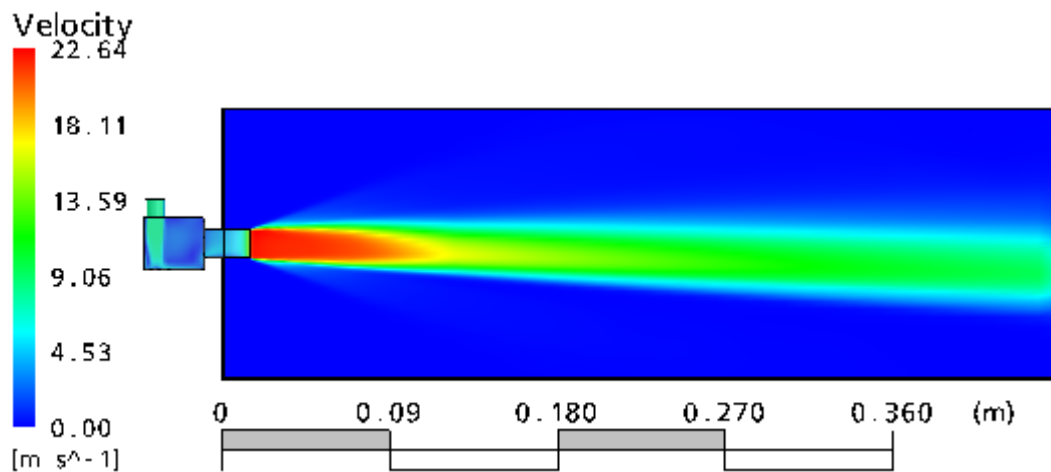

Figure 14: Velocity vs. Distance (Highly-Ranked Design)

One of the most important criteria for the design of this nozzle is to have the flow at least 15 m/s for at least 6 centimeters to make sure that the flow is hitting the slicing area. When

looking at this figure it can be seen that the flow keeps a velocity of over 18.11 m/s for at least .09 m or about 9 cm. This figure depicts the desired results for the design of the nozzle in terms of velocity at the slicing zone. The streamline also does not split down the middle, or get interrupted in any way until the flow is sprayed further than needed. This is why this design was chosen to use as a foundation and work off of.

Phase 3

The third round of CFD simulation reflected the latest developments in the known information such as tubing size. The new tubing size was ¼ inch outer diameter with 1/8 inch inner diameter. This change in tubing size obliged the team to recalculate nozzle geometry based on the new information. The nozzle outlet width remained the same at 15mm but the outlet height was adjusted to 0.50mm.

This round of CFD simulations also sought to address the internal shape of the tube attachments. The tubing attachments selected are of the type showed in Figure 15. These fittings allow for easy “push to connect” connection of the tubing to the nozzle. The fittings also have a ¼ Male NPT thread to easily be incorporated into the coolant nozzle design.



Figure 15: Coolant tube fitting

The 90 degree elbow fitting could be used and oriented at the back or the nozzle reservoir, since it does not offer any threat of being obstructed by the rest of the machine like a straight fitting would. However a straight fitting without an elbow could be utilized from the side of the nozzle reservoir. These are the two cases explored by this phase of CFD testing.

This round of testing also implemented some of the knowledge gained from the previous rounds. The internal geometries were designed to have no sharp angles where possible. Instead, they had rounds or smooth transitions wherever possible. The first case of this phase can be seen in Figure 16.

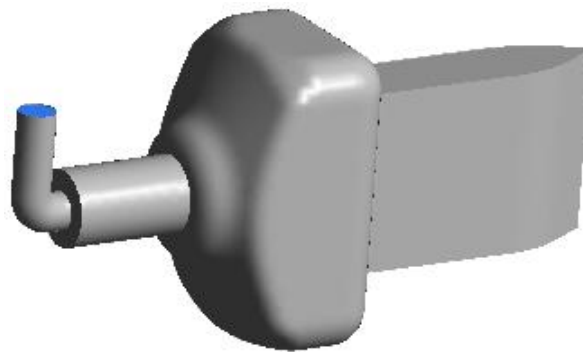

Figure 16: Nozzle with reservoir and elbow fitting

The elbow and cylindrical feature represent the inside of the fitting, as measured. The velocity characteristics associated with this nozzle can be seen in Figure 17. This is the plane that the stream passes through 1.5 cm from the nozzle outlet. It is evident that the stream is fairly cohesive with a velocity above 15 m/s nearly across its entire span.

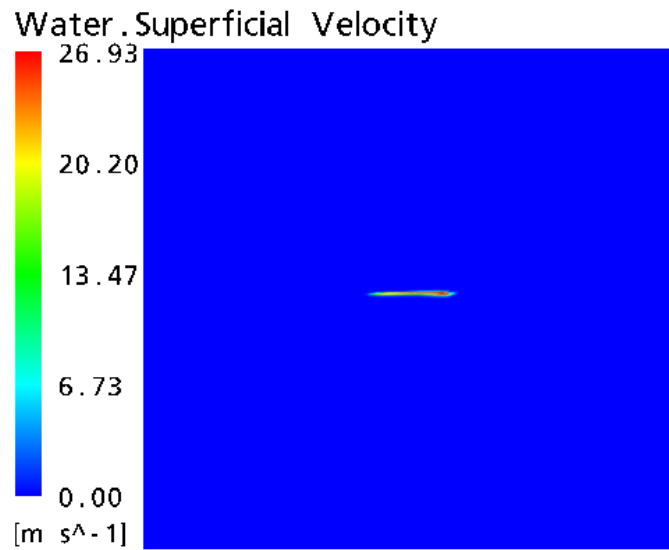

Figure 17: Velocity of water at the plane 1.5 cm away from the nozzle

The second case for this phase can be seen in Figure 18. This design used a straight tube fitting attached to the side of the nozzle. It is important to note that the distance from the front of the nozzle to the back of the reservoir in this design is the same as the distance from the front of the nozzle to the back of the elbow in the previous case. This accounts for the space constraints applied to both nozzles.

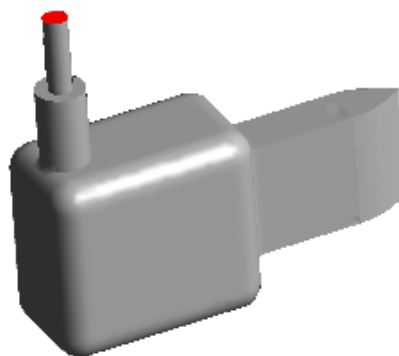

Figure 18: Nozzle with reservoir and straight fitting

The superficial velocity at 1.5 cm associated with this design can be seen in Figure 19. The velocity shown in this image is below 15 m/s across the entire span of flow. This flow is unacceptable; therefore, the previous case studied is superior to this design.

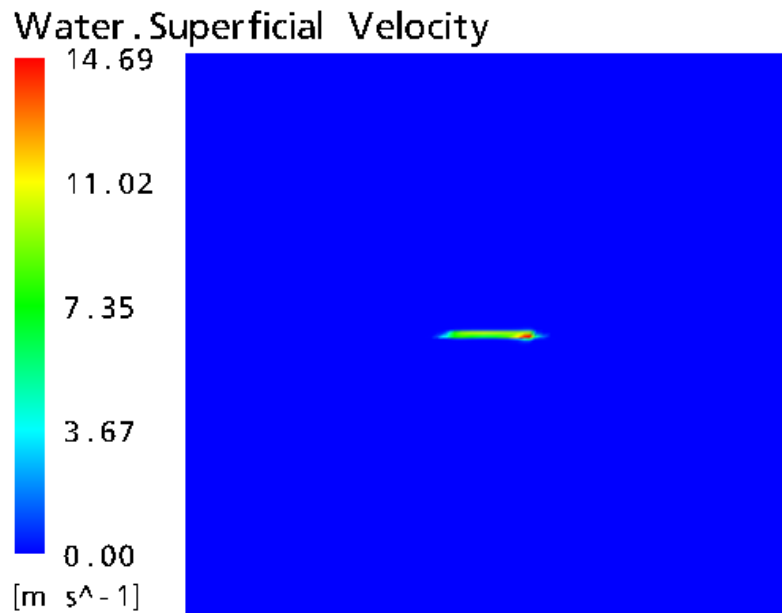

Figure 19: Velocity of water at the plane 1.5 cm away from the nozzle

The subsequent design incorporated aspects that were learned and established from previous CFD cases. This design incorporated the 90 degree elbow as was present in the earlier cases in the more favorable orientation of being fed from the side, parallel to the ground. The inlet to the nozzle is again at the rear of the reservoir. The internal reservoir geometry was altered in an attempt to create more desirable flow characteristics at the outlet. This internal geometry, as seen in the following figure, incorporates a smooth blend from the circular inlet as dictated by the threaded fitting to the rounded rectangular shape of the reservoir. This design maintains the nominal length as used in earlier iterations.

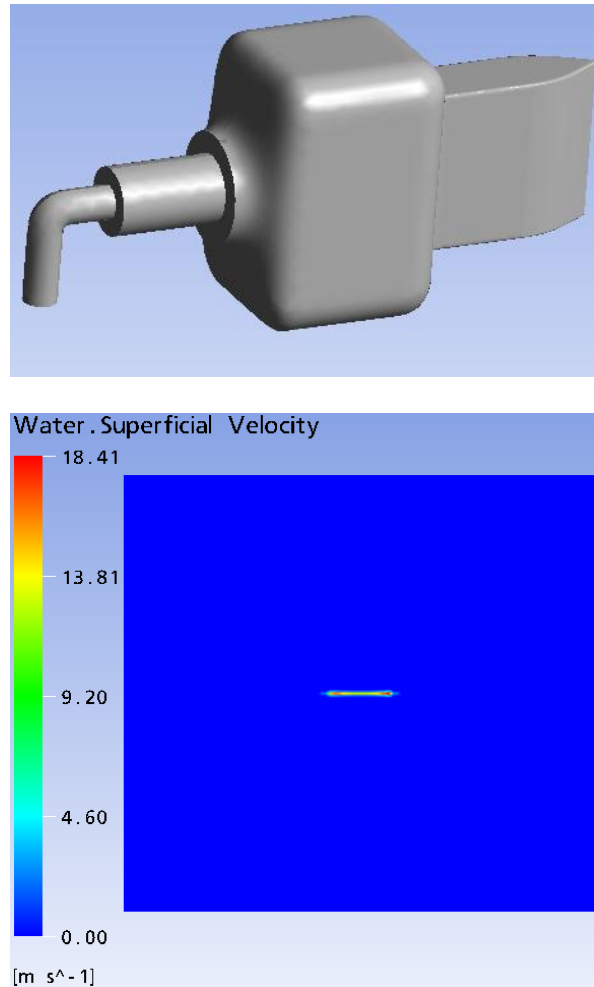

Figure 20: Nozzle with blended reservoir and elbow fitting and corresponding velocity at 1.5cm

In studying the flow conditions present in this design and applying the understanding of flow patterns as gathered from this and previous CFD simulations, it was determined that the length of the transitional blend should be increased. This elongation would provide for greater radii and smoother transition into greater cross-sectional area of the reservoir. There was also the consideration that all interior positive radii must be greater than 1/8 inch to allow for the

pocket to be made with a ¼ inch diameter ball end mill. Additional CFD results can be found in the appendix.

MACHINING

Initially, the nozzle dimensions were sufficiently large as to make traditional machining at WPI an option. The original nozzle outlet was large enough to allow for a 1/16” end mill. As the project progressed, our group learned that the nozzle outlet calculations called for an outlet height smaller than 1/16,” which can be seen in Appendix A. The newly calculated nozzle outlet size would be the same 1.5 cm wide but a mere 0.5 mm in height. This ruled out machining solely with mills, since the outlet size is smaller than 1/16” (1.5875mm). This size was the smallest size deemed reasonable for use. With the notion of fabricating the nozzles entirely at WPI or a machine shop contracted by Saint-Gobain, several machining strategies were devised to solve the problem of machining our nozzle. Our group’s thought process can be seen in the flowchart in Figure 15.

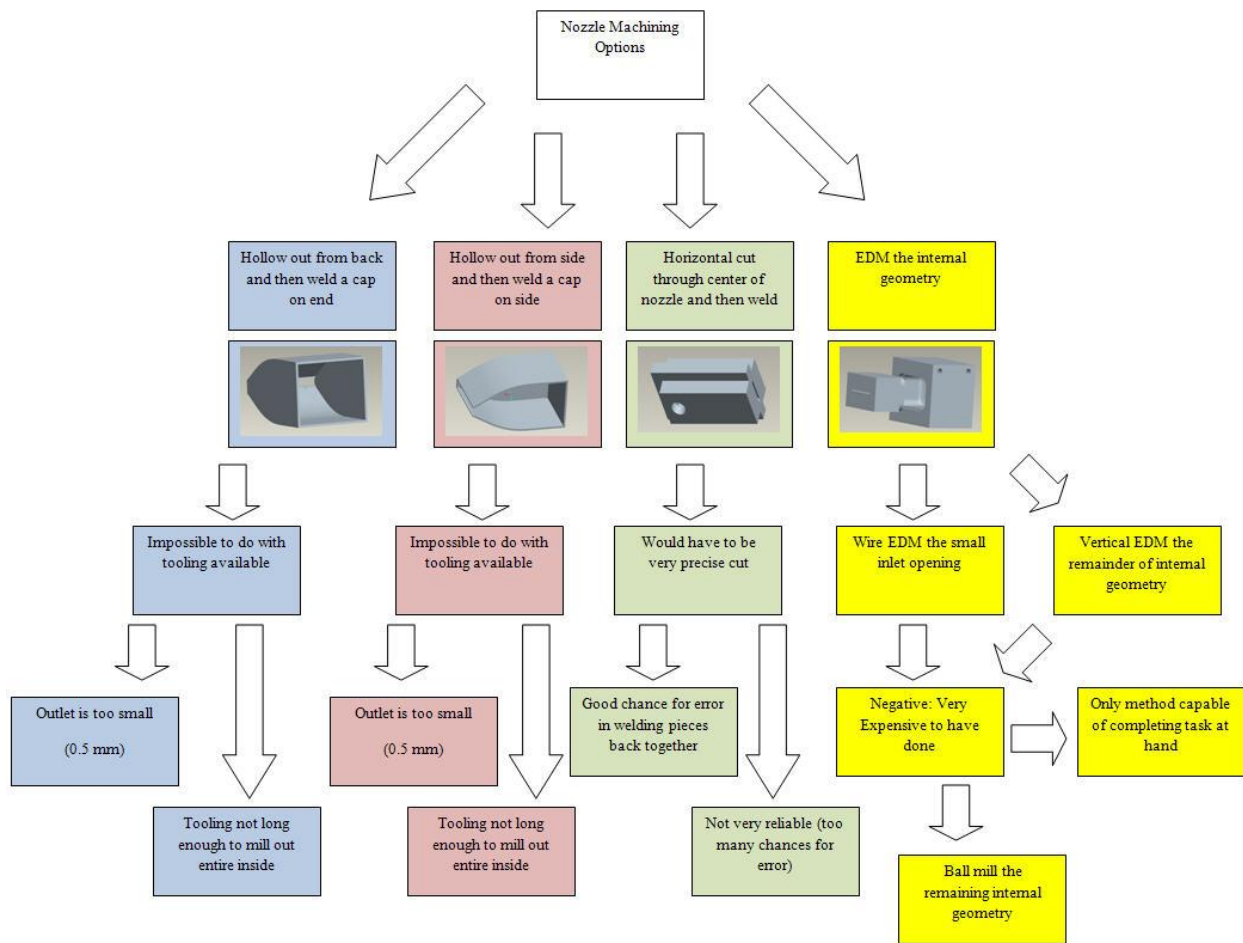

Figure 21: Flow Chart of Ideas of Machining the Nozzle

The first idea included hollowing out the inside of the nozzle from the rear with the use of a ball end mill to assure smooth inner surfaces. The outer surfaces are unimportant as long as they are not overly bulky or obstructive. If this procedure would be the choice, then our group would then enclose the nozzle with cap on the rear of the nozzle. An example of this can be seen in Figure 16. The cap would include a threaded hole to accept the coolant tube. This method would not allow for a rectangular exit cross-section, as the tooling, no matter how small, would leave a radius in the inner corners of the work piece. Unfortunately, the outlet was too small

machine with any type of mill. Also, even if our group found a different method to machine the outlet, the milling tooling would not be able to reach all of the depths of the hollowed out nozzle. The length of the nozzle was 0.809 inches, but the tooling could only reach 3/16 of an inch. This course of thinking can be seen in Figure 15, following the blue boxes in the flowchart.

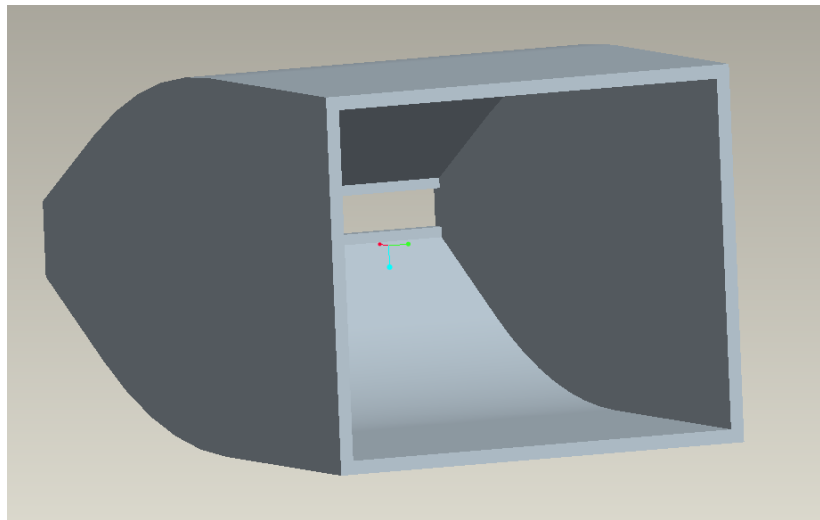

Figure 22: Nozzle Hollowed out from Behind

Another option is to hollow out the nozzle from the side. After the nozzle would be hollowed out, our group would again either use an adhesive or weld a cap with a threaded hole on it to fit the tube onto the side of the nozzle. By milling the nozzle this way, all spaces of the nozzle would be able to be hollowed out, while the first method would have not been able to. However, similar to the problems from Figure 16, the machining design, in Figure 17, would face the same problem, which can be seen in Figure 15. The necessary tooling for machining the outlet as well as reaching the necessary depths from the side of the nozzle was not available. This process for machining can be seen by following the red boxes in Figure 15.

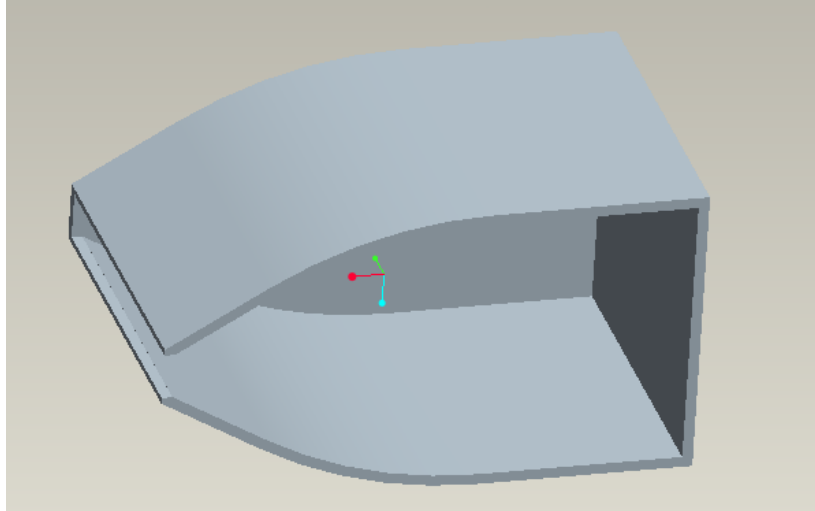

Figure 23: Nozzle Hollowed out from the Side

The last option for machining this nozzle with the tooling at WPI would be to use a horizontal cut to split the nozzle into two symmetrical pieces. This idea can be seen in Figure 18. After the nozzle was cut in half, the insides of each section would be hollowed out. Once the necessary sections of the nozzle were hollowed out, the two pieces would be welded back together. Unfortunately, this would take a great deal of precision welding on the outside. This would also require surfaces that were true within tight tolerances, as the outlet height was on the scale of one millimeter. In addition to this area of concern, any section on the interior of the nozzle that is slightly offset may affect the flow through the nozzle and create unnecessary turbulence. The thoughts behind this option can be followed through the green boxes in Figure 15.

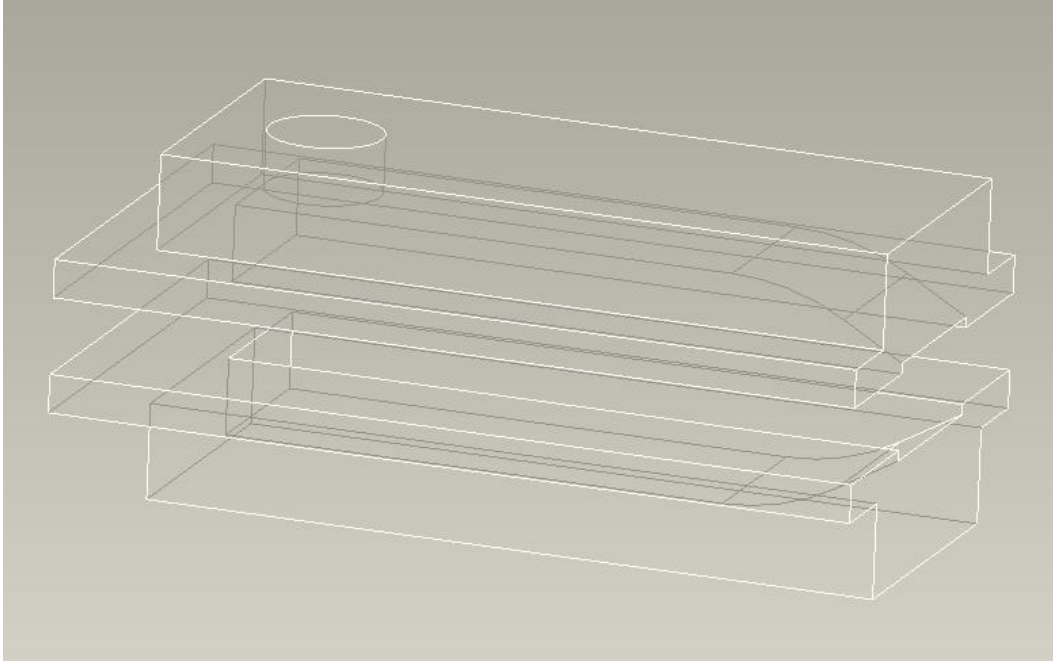

Figure 24: Nozzle Cut in Half and Welded back Together

However, all of the previously mentioned strategies were rendered useless after the re-dimensioning of the nozzle based on new source tube geometry. This dilemma led the group to consider electrical discharge machining (EDM). This method essentially burns material out of a work piece using an electrode of a given shape, or a wire. This process could allow us to expand beyond the confines of milling machines. EDM is generally more expensive than conventional processes, but it would allow us to further optimize the nozzle for our application, and, most importantly, would allow us to specify outlet an outlet dimension of 0.5 mm. This process can be seen by following the yellow boxes in Figure 15.

The strategy at this point in the design process was to have the smaller geometries of the nozzle fabricated through the use of EDM, and achieve the larger, less vital geometries through milling operations. The reasoning behind selecting machining the reservoir component at WPI can be seen in Figure 19. Using the machining mill instead of the EDM would serve multiple

purposes. The first would be to minimize EDM costs. The second would allow the group to optimize the flow characteristics of the reservoir leading to the nozzle. The nozzle section would fit into the reservoir to which the coolant would be fed. This strategy can be seen in the figure below.

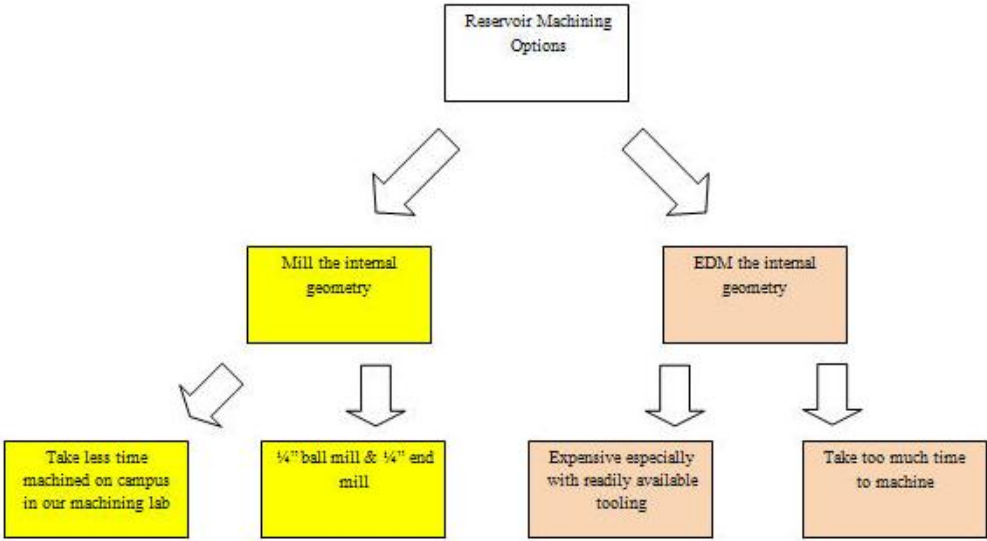

Figure 25: Flow Chart of Ideas of Machining the Reservoir

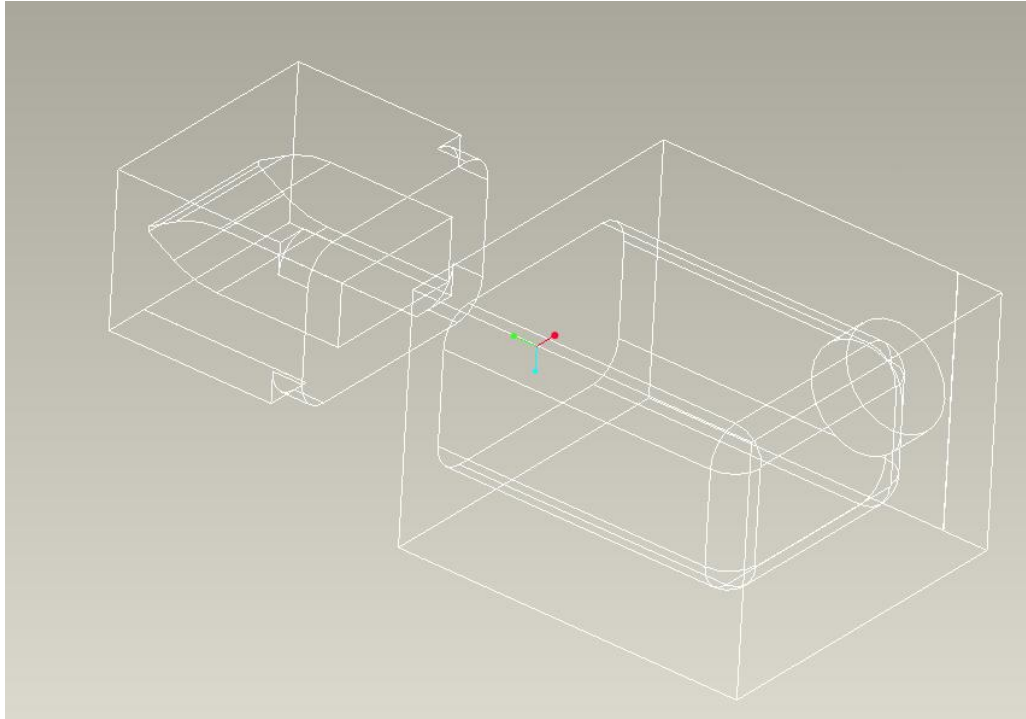

Figure 26: Nozzle Fits into Reservoir

As seen in the figure, the block that contained the complex nozzle geometry would fit into the reservoir, and then it was sealed by means of welding the rectangular interface that connected the two pieces. The nozzle was manufactured through EDM, while the reservoir was machined through mill work.

The group was referred to Bisson Tool Company for its EDM needs. Bisson Tool originally suggested using a 400 series stainless steel like 420. This was due to its magnetic properties. Some of the fixtures they use utilize magnetic holders. However, the group decided a 316 stainless steel would fit our needs better. The 316 did not require post-weld annealing as 400 series steels often do. The 316 also lent itself to welding more readily due to its lower carbon content. The 316 grade stainless steel was considered “marine steel” as it was commonly

used in oceanographic applications and had a high resistance to corrosion in chemical environments.

The group then determined the necessary tooling to create these pieces. In the design, any inner radius was made 1/8" or larger to allow for the use of 1/4" diameter milling tools. The entirety of the milling was then accomplished using 1/4" square end mills and 1/4" ball end mills.

Results

Based on the CFD analysis and calculations, the team had an idea of what type of results to expect from the final design. The following figure is a picture of the two nozzles and reservoirs side by side, after they had been machined and completed.

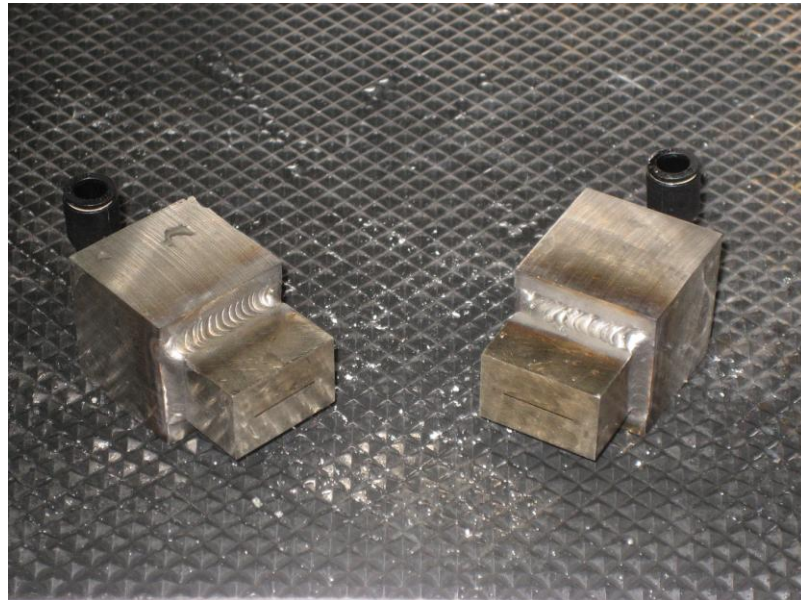

Figure 27: Final Product

Once the final design was machined and completed, it was brought to Saint-Gobain to test. Based on parameters supplied by Saint-Gobain, the nozzle should have kept a uniform flow

and covered the span of 1 cm worth of wire for at least 5 cm. The following figure shows an aerial view of the nozzle operating.

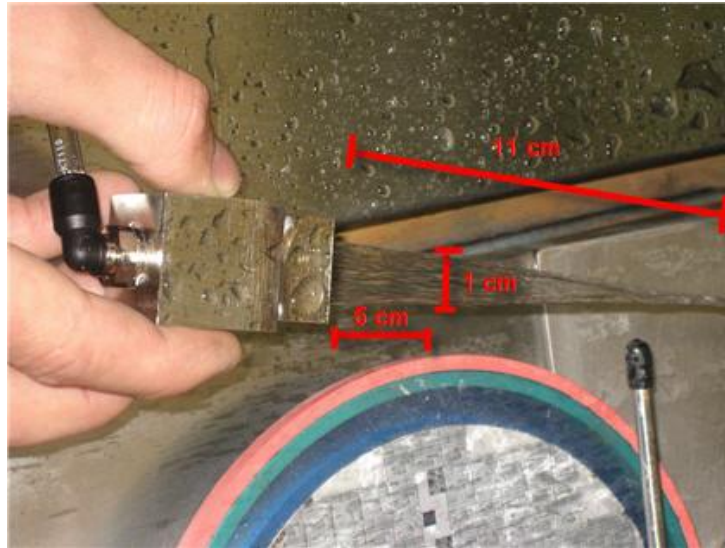

Figure 28: Parameters Met During Testing

As seen in Figure 28 the flow exiting the nozzle covered the width span of 1 cm up to 5 cm which is exactly what the team was hoping to find. The exiting water also reaches 11 cm before it comes to a smaller straight stream of flow. Another key discovery through this testing is that the flow exiting the nozzle never turns to mist at any point. The following figure shows another view of the nozzle.

The CFD analysis was helpful in the fact that it helped the team get an idea of what type of flow to expect from each iterated design. Although, once this nozzle was tested it differed from the CFD analysis slightly. From the CFD results, it was expected that the flow of coolant would start off smaller in width and then go off to a v-shape the further the flow was away from the nozzle. In reality the width span of the flow started off wider at the nozzle outlet and then

further away came to a smaller width. The nozzle once tested also kept a nice straight uniform flow even better than the CFD analysis had suggested. The flow stays linear for 6 cm before it starts to veer off and lose its unity. This is shown in the figure below.

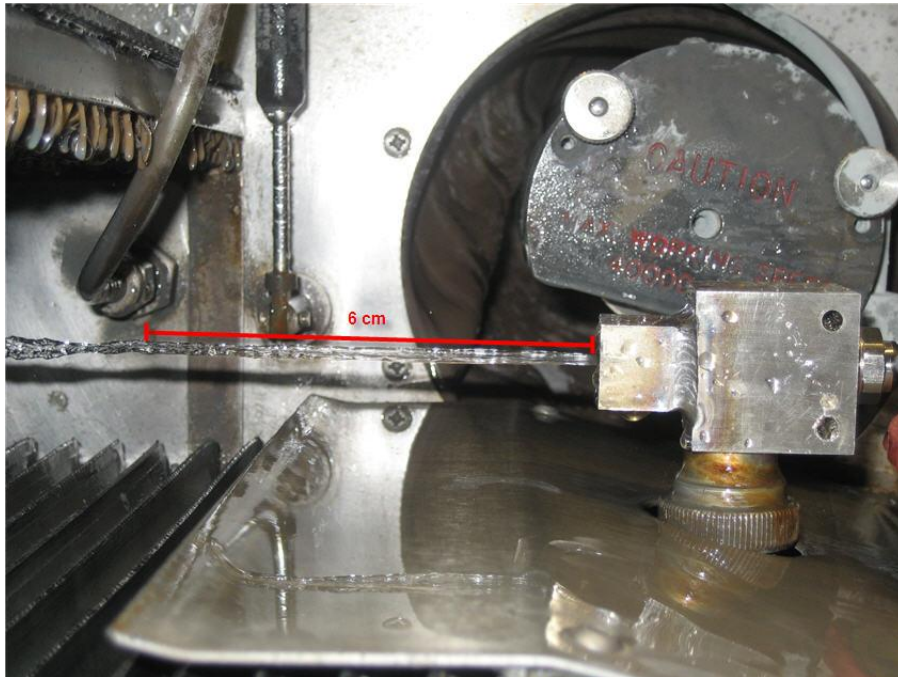

Figure 29: Linearity of Flow over 6 cm

Conclusion

Saint Gobain was in need of a coolant system for their new diamond wire slicing machine. Using parameters determined by Saint Gobain, multiple nozzles were designed and tested through CFD analysis in order to obtain the most efficient system. One this design was complete; it was machined and then tested at Saint Gobain to make sure that all parameters were met. All parameters that they were looking for were met, proving the overall system to be very efficient. The coolant system will be incorporated into their new diamond wire slicing machine, and then shipped off to Germany to be used for many years to come.

- Different nozzles were designed through calculations and given parameters
- Each design was simulated through CFD analysis to choose a final design
- Final design was manufactured and tested at Saint Gobain

WORKS CITED

Diamond Wire Technology. "Cutting with Diamond Wire." 10 April 2008.

<http://www.diamondwiretech.com/diamond_wire/cut_dia_wire.html>.

Fox, Robert W., Alan T. McDonald, and Philip J. Pritchard. Introduction to Fluid Mechanics Sixth Edition. United States of America: John Wiley & Sons, Inc, 2006.

Hardin, Craig, Jun Qu, and Albert J. Shih. "Fixed Abrasive Diamond Wire Saw Slicing of Single-Crystal Silicon Carbide Wafers." Materials and Manufacturing Processes 19 (2004): 355-367.

Innovative Organics. "AmberCut Products." 20 April 2008.

<http://www.innovativeorganics.com/Data/Element/Node/Category/category_edit.asp?element_ch_id=C0000000000000001593>.

Kao, I., et al. "Wafer Slicing and Wire Saw Manufacturing Technology." Stony Brook, NY: SUNY Dept. of Mechanical Engineering.

Koshal, Dan. Manufacturing Engineering Reference Book. London: Butterworth-Heinemann Ltd., 1993.

Leblanc-Shoemaker, Robert and Gina Melendez. "Grinding Mechanisms and Effect of Coolant Application in Thin Precision Slicing of Electronic Materials." Major Qualifying Project. Worcester Polytechnic Institute, 2007.

"Manufacturing." Encyclopædia Britannica. 2008. Encyclopædia Britannica Online. 20 April 2008.

"Saint Gobain." Saint Gobain. 1 September 2007. <<http://www.saint-gobain.com/en/html/groupe/strategie.asp>>.

Silicon Valley Microelectronics, Inc. "Silicon Wafers." 10 April 2008.