

Design and Manufacturing of a
Portable Single-Switch Activated Bowling Game

A Major Qualifying Project Report
submitted to the Faculty
of the
WORCESTER POLYTECHNIC INSTITUTE
in partial fulfillment of the requirements for the
Degree of Bachelor of Science
by

Jeff Prunera

Jacob Saffron

Jonathan A. Welch II

Date:

Approved:

Professor Allen H. Hoffman, Major Advisor

Abstract

The Seven Hills Pediatric Center in Groton, MA has asked for a bowling game that is designed for their residents whom all have special needs. It has been determined that there are four essential elements to this bowling game. These elements consist of: a ball launching mechanism, a ball catching device, a ball returning system, and some method for easing pin setup. The outcome of this project is a bowling system that can be easily stored, moved between rooms, and can be used on a daily basis.

Table of Contents

Abstract	i
Table of Contents.....	ii
Table of Figures	vi
1. Introduction	1
2. Project Goal.....	2
3. Background.....	3
3.1 Commercial Products.....	4
Silly Six Pins	4
Bounce n Splash	5
Electronic Bowlercade	6
3.2 Patents	6
Toy Bowling Game.....	6
Bowling Ball Return Mechanism.....	7
Collapsible ramp for projecting bowling balls	9
Ball Game Device	11
4. Design Specifications	13
4.1 General Design Specifications	13
4.2 Launching Mechanism Specifications	16
4.3 Specifications for a Ball Retrieval Mechanism.....	16
4.4 Specifications for an alley (if one is required)	17
4.5 Specifications for a backstop.....	18
4.6 Specifications for a pin base.....	18
5. Preliminary Design	19
5.1 Design Descriptions for a Ball Launcher	19
Idea 1.....	19
Idea 2.....	20

Idea 3.....	20
5.2 Design Descriptions for an Alley	21
Idea 1.....	21
Idea 2.....	22
Idea 3.....	23
Idea 4.....	24
5.3 Design Descriptions for a Ball Return	26
Idea 1.....	26
Idea 2.....	27
Idea 3.....	28
5.4 Design Selection.....	29
6. Final Designs/Prototypes.....	31
6.1 Launching Ramp	31
6.2 Pin Base	35
6.3 Backstop/Ball Catcher	36
6.3.1 The Ball Catcher	36
6.3.2 The Backstop Panels.....	37
6.4 Ball Return.....	39
7. Manufacturing	41
7.1 Launching Mechanism.....	41
7.2 Pin Base	44
7.2 Pin Base	48
7.5 Ball Return.....	48
8. Testing Phase 1.....	50
8.1 Stage 1: In-house testing for functionality by design team	50
8.2 Stage 2: Seven Hills Staff.....	52
9. Redesign and Rebuild	55
9.1 Backstop	55

9.2	Ball Catcher	56
9.3	Launching Ramp	56
9.4	Pin Base	57
10.	Testing Phase 2.....	58
	In-house testing for functionality by outside sources	58
11.	Results.....	60
11.1	In-House Testing for Weight and Dimension	60
11.2	Battery Life Results	60
11.3	Analysis of Outside Testing Results	61
11.3.1	Pin Setup Statistical Analysis	61
11.4	Design Specification Results.....	62
11.4.1	General Design Specifications	62
11.4.2	Launching Mechanism Specifications.....	64
11.4.3	Specifications for a Ball Retrieval Mechanism	64
11.4.4	Specifications for a backstop	65
11.4.5	Specifications for a pin base	66
12.	Conclusion	68
13.	Recommendations	68
14.	References.....	69
15.	Appendices	71
	Appendix A: MathCAD Calculations.....	71
	Ramp Ball Velocity Calculations.....	71
	Appendix B: Budget Summary	72
	Electronics	72
	Ball Release (not reimbursed)	72
	Building Materials	72
	Total Reimbursed \$391.87	72
	Grand Total 433.82.....	72

Appendix C: Engineering Drawings.....	73
Pin Base	73
Ball Return.....	75
Ball Catcher	76
Incline panel for the Ball Catcher	77
Backstop Panels.....	78
Backstop Panel Supports	79
Launching Ramp	80

Table of Figures

Figure 1: Silly 6 pins Bowling Game (“Silly Six Pins”, Hasbro).....	4
Figure 2: Bounce n Splash by Wham-O (Wham-O, “Bounce n Splash”).....	5
Figure 3: Electronic Bowlercade Bowling Game (Amazon, “Electronic Bowlercade”)	6
Figure 4: Bowling Pins and Recesses from Patent 4832339 (Danielak et al, 1989)	7
Figure 5: Top View of the Bowling Ball Return Mechanism from Patent 3831939 (Lorber, 1974)	8
Figure 6: Side View of the Bowling Ball Return Mechanism from Patent 3831939 (Lorber, 1974)	9
Figure 7: Top and Side View of a Collapsible Bowling Ramp from Patent 5314384 (Ross- Sullivan, 1994).....	11
Figure 8: Bowling Ramp from Patent 5431398 (Simpkins, 1995).....	12
Figure 9: Sketch of Proposed Ramp Idea 1	19
Figure 10: Sketch of Proposed Ramp Idea 2.....	20
Figure 11: Side View Sketch of Ball Cannon Design	21
Figure 12: Sketch of Proposed Alley Idea 1	22
Figure 13: Sketch of Proposed Alley Idea 2	23
Figure 14: Sketch of Proposed Alley Idea 3	24
Figure 15: Sketch of Proposed Alley Idea 4	25
Figure 16: Detail of Proposed Alley Idea 4	25
Figure 17: Sketch of Proposed Ball Return Idea 1	26
Figure 18: Sketch of Proposed Ball Return Idea 2	27
Figure 19: Sketch of Proposed Ball Return Idea 3	28
Figure 20: Ramp General View	31
Figure 21: Schematic of Gate Mechanism Electronics	33

Figure 22: Detail of Gate Swing	33
Figure 23: Side View of Launching Ramp	34
Figure 24: CAD Model of the Pin Base	35
Figure 25: Ball Catcher Prototype	37
Figure 26: Backstop Panels in Operating Position	38
Figure 27: Backstop Panels in Stored Position	38
Figure 28: Ball Return CAD Model	40
Figure 29: Ball Return Prototype.....	40
Figure 30: General View of Launching Ramp.....	41
Figure 31: Detail of Rail Ends	42
Figure 32: Screw Hole Detail.....	42
Figure 33: Latch Detail.....	43
Figure 34: Cut Leg Detail.....	44
Figure 35: Backstop Panel with Support	46
Figure 36: Ball Catcher Without the Incline Slope	47
Figure 37 Incline for Ball Catcher	47
Figure 38: Original Backstop Design	55
Figure 39: Improved Backstop Design.....	56
Figure 40: Graph of Outside Test Results	61

1. Introduction

The game of bowling has been around since ancient times and has been played by millions of people around the world. The earliest known mention of bowling in America is in the story Rip Van Winkle written by Washington Irving (Seagrist, 2002). The game of bowling involves a set of ten pins arranged in a triangular pattern at the end of a long, straight, narrow pathway otherwise known as an “alley”. The game is played by rolling a ball down the alley and knocking down as many pins as possible in two or fewer rolls of the ball. When all the pins are knocked down in exactly two rolls of the ball this is known as a “spare” and when all the pins are knocked down in one roll this is known as a “strike”. The object of the game is to accumulate as many points as possible where each pin knocked over equals one point. Extra bonuses can be awarded through strikes and spares.

Our project is centered around creating a bowling game for the residents of the Seven Hills Pediatric Center in Groton, MA. The Seven Hills Foundation is a non-profit organization spread throughout Massachusetts which assists people with “physical, developmental, emotional, or other life challenges” (Seven Hills Foundation, About Us). The Pediatric Center in Groton, MA is a program belonging to the Seven Hills Foundation which assists children and young adults with severe cognitive disabilities.

Part of the curriculum at the pediatric center includes playing a modified bowling game that can be brought into various rooms and set up quickly. However, the game currently in use involves considerable assistance from the staff to reset each frame after a person bowls. Seven Hills has requested that a newer game be developed that would involve less staff intervention and promote resident independence through automation of components.

2. Project Goal

The new game will need to be mobile enough to be brought into a variety of rooms and compact enough to stow in an average-sized storage closet. The proposed game will utilize a large button that the residents can push to activate the launching device. The ball will then roll down an alley to a device which holds the bowling pins. This device will have an electronic package which enables it to provide audio feedback to the users. After the pins are knocked down the ball will be moved to a ball return device which will return the ball back to the user. This process should be as automated as possible but the staff may still have to set up the pins before each frame.

All of the components of the game are to be modular and as lightweight as possible to facilitate the staff moving them around the building to different rooms. The staff should also be able to store each component in a regular sized closet.

3. Background

While visiting the Seven Hills Pediatric Center in November 2008, the project team toured the facility and observed the residents playing their current version of bowling. It consisted of a narrow, wooden ramp which rested on the armrests of the residents' wheelchairs. On the floor was a triangular pattern made of paper with ten places for standard-sized plastic pins to sit on. The ball itself was made of a hard rubber yet still retained elastic properties and weighed about two pounds. To play, a resident would push the ball down the ramp on his/her own will or with the aid of a staff member. The ball would travel along the bare floor and strike the pins at the opposite end of the room. Behind the pins, a standard gymnastics mat was stood on end to stop the ball from rolling after it strikes the pins. To reset a frame, the staff would gather the pins together, pick them up by hand, and re-stand them up on the placemat. They would also have to track down the ball and carry it back to the ramp. Overall, the most time consuming task performed by the staff was lifting and moving the ramp on and off the residences' wheelchairs. It was apparent that these tasks were burdensome to the staff, and they expressed great interest in minimizing these steps.

In addition to improving their bowling game, other points of interest came into consideration. Each resident has his or her own custom fitted wheelchair that all have different resting dimensions for the ball ramp to sit on. The design will need to address this in a manner that can accommodate any wheelchair design. The staff also expressed an interest for the game to be played in several different rooms of varying size. A game design was suggested that could change its length to adapt to various room dimensions. For an input interface, each resident had his/her own means of pressing a button. Some residents could press it with his/her hands in front

of them while others could only press it with the side of their head. This means that the design would have to have a universal input in order to accommodate any resident. Currently, the residents have to physically push the ball, which means the staff would usually have to give “hand-over-hand” aid in order for the game to proceed. Furthermore, there is the sanitary aspect to consider with the residents touching a ball that is constantly rolling on the floor.

3.1 Commercial Products

Silly Six Pins

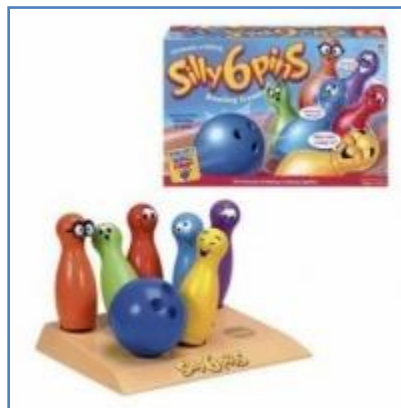

Figure 1: Silly 6 pins Bowling Game (“Silly Six Pins”, Hasbro)

This product (Figure 1) contains a square, electronic base with depressions on top for the pins to fit into. More importantly, it makes audible noises and voice phrases when pins are knocked down, as well as keeping score for each turn. The main drawback of this product is that it only contains six pins instead of the preferred ten pins. It also only keeps score for a single turn instead of maintaining score for an entire game (Hasbro, “Silly Six Pins”).

Bounce n Splash

For the actual alleyway, various ideas have been brainstormed to give a flat surface elevated off the floor. One idea involves an inflatable pad that could be rolled up and stored away when not in use. A similar product (Figure 2) is an inflatable “Slip n’ Slide” by Wham-O (Bounce 'n Splash).



Figure 2: Bounce n Splash by Wham-O (Wham-O, “Bounce n Splash”)

The main problem with inflatables is that it does not provide a solid, flat surface for the ball to roll down. Also, anything that is pliable enough to be rolled up and inflated will naturally expand outward spherically and will not provide a flat planar surface. A remedy for this dilemma is to only inflate side bumpers and not the alley surface (Wham-O, “Bounce n Splash”).

Electronic Bowlercade



Figure 3: Electronic Bowlercade Bowling Game (Amazon, “Electronic Bowlercade”)

The children’s toy (Figure 3) has a similar design intent as our device in that it is a compact bowling game with a ball return and pin setter. The main concern with this product is that the pins only swing up and then swing down to their original place after the ball rolls through. However, this design does display a means of breaking down an alley into a compact space. This is accomplished by a roll-up mat for the alley floor outlined by a sectional frame that locks together. (Amazon, “Electronic Bowlercade”).

3.2 Patents

Toy Bowling Game

U.S. patent number: 4832339

Abstract

“A toy bowling game for young children includes a soft bowling ball and a ramp

providing an angled bowling surface. Adjacent the raised end of the ramp are a number of wells with a pin elastically tethered to the bottom of each well. Each pin has a rounded bottom that fits into a depression adjacent the front upper edge of its respective well for setting up the pin. The underside of a flange on the pin, which is above and around the rounded bottom, engages the bowling surface” (Danielak et al, 1989).

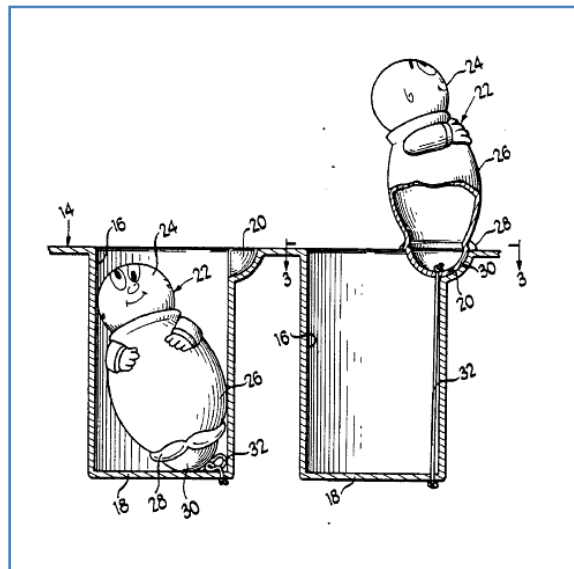

Figure 4: Bowling Pins and Recesses from Patent 4832339 (Danielak et al, 1989)

This patent (Figure 4) gives a creative and practical means of eliminating bowling pins after they have been struck by the ball. However, it requires a deep recession below the bowling surface for the pins to fall into. It also doesn't reset easily unless a separate mechanism is designed to push the pins back up to the sitting position.

Bowling Ball Return Mechanism

U.S. patent number: 3831939

Abstract

“A mechanism for automatically returning a bowling ball to the bowler, in a toy bowling game, is described. The mechanism comprises of an inclined apron which the ball travels up after passing through the bowling pin area. If the ball has been bowled with sufficient force, it will pass along the complete extent of the inclined apron and fall off the top of the apron onto a ramp which is inclined downwardly to either side, from its apex which is aligned with the center line of the apron. The ball then passes onto either a right or left hand downwardly inclined ramp from which it rolls back to the bowler. A one-way gate is provided at the lower end of the apron for permitting the ball to pass onto the apron but preventing the ball from returning into the bowling pin area where the ball has been bowled with insufficient force to carry it to the top of the apron” (Lorber, 1974).

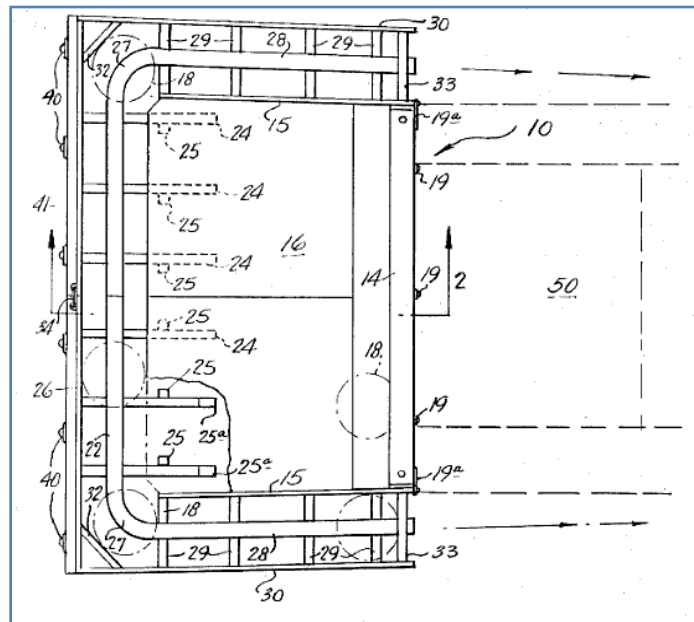

Figure 5: Top View of the Bowling Ball Return Mechanism from Patent 3831939 (Lorber, 1974)

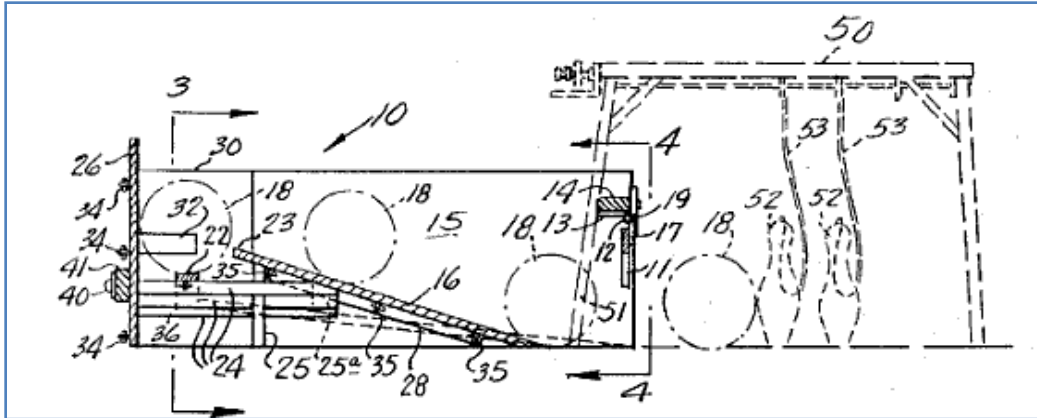

Figure 6: Side View of the Bowling Ball Return Mechanism from Patent 3831939 (Lorber, 1974)

This design (Figures 5 and 6) gives a simple way to collect the ball after striking the pins and then returning it to the bowler. The ball rolls up an inclined plane after striking a detachable pin setup. Depending on which side of the ramp the ball rolls up, it will then return down a separate ramp on either the left or right side of the main incline. The major advantage of this design is that it requires no moving parts and nothing is powered. The major flaw with this model is that it relies on sufficient momentum to push the ball up the apron (Figure 6, part 16) after striking the pins. However, this design could be adapted to have a motorized lift to carry the ball up a height to give it the potential energy needed to return the ball to the bowler. Another advantage of this design is that it allows for return channels to be attached to where the return ramps end (Figure 5, part 33).

Collapsible ramp for projecting bowling balls

U.S. patent number: 5314384

Abstract

“The child's bowling aid device resembles a portable bowling ball holding rack

with attached bowling ball launching ramp and is adapted to permit a child to easily hold the bowling ball on the rack and then ease it forward off the rack through the launching ramp, after aiming the ramp, in order to roll it onto a bowling lane and knock down bowling pins. The device includes first and second spaced parallel vertical side plates, each with a flat bottom, elevated rear end, a dish-shaped bowling ball-retaining top portion and a front top portion which slopes down and forwardly to serve as a launching ramp. Spaced rear and front transverse vertical crossplates interconnect the side plates. The rear transverse plate is taller than the front transverse plate. Preferably, all plates are flat and releasably connectable and form a kit capable of being transported in disassembled condition in a bag or the like and then being assembled at a bowling alley for use. Preferably each plate is light in weight and the side plates bear finger grooves to facilitate movement of the assembled device into aimed position adjacent a bowling lane. An improved method of aiding a child in learning to bowl involves the use of the device with a bowling ball in a game simulating conventional bowling” (Ross-Sullivan, 1994).

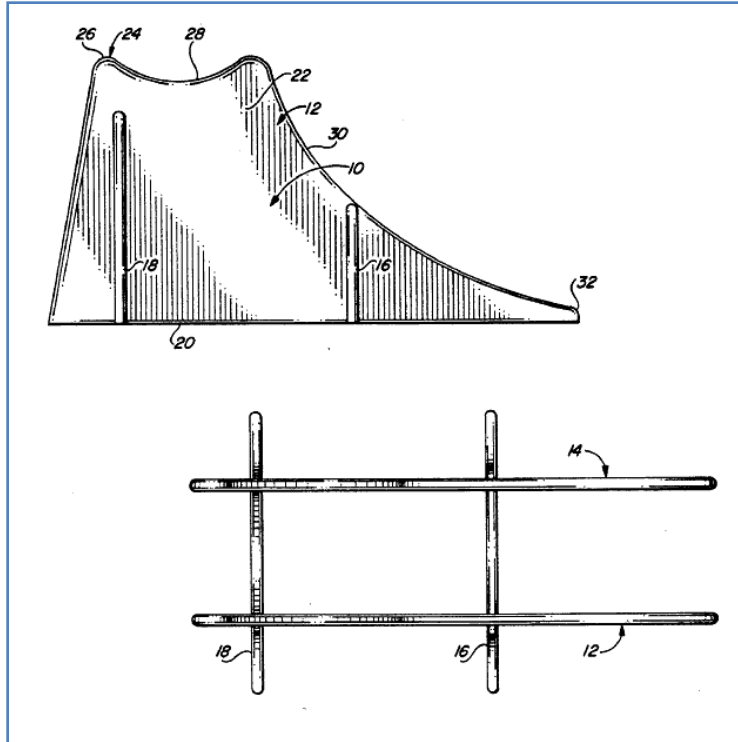

Figure 7: Top and Side View of a Collapsible Bowling Ramp from Patent 5314384 (Ross-Sullivan, 1994)

This free standing ramp idea contains a top reservoir (Figure 7, part 28) and two profile panels (Figure 7, parts 12 and 14). The purpose of this design is to assist someone unable to throw a bowling ball properly. The ball sits in the top trough, and the user simply pushes it over the swell and down the ramp. The most notable feature of this design is that it can easily be taken apart and the panels all lie flat.

Ball Game Device

U.S. patent number: 5431398

Abstract

“A ball game device is formed by an elongated generally upright open end ball

receiving tube. In one embodiment the tube has a block adjacent to its depending end for diverting a ball dropped into the tube in a predetermined lateral direction. In another embodiment the depending end portion of the tube is curved in a lateral ball diverting direction and is supported by a base” (Simpkins, 1995).

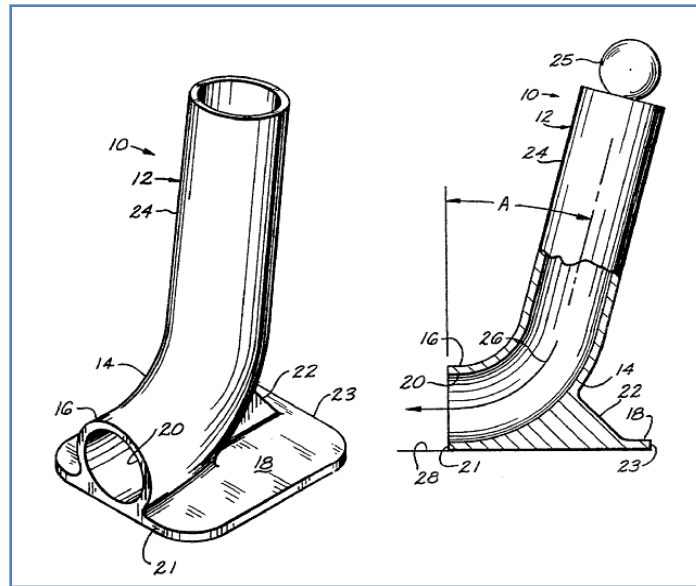

Figure 8: Bowling Ramp from Patent 5431398 (Simpkins, 1995)

This design (Figure 8) shows an alternative to an inclined plane launching ramp where the incline angle is critical to the balls acceleration and path direction. By using tubes, they could be oriented vertically to greatly reduce overall size and give a more exact path after leaving the launching device. However, a tubular design would create extra friction on the ball, causing the final maximum speed to be reduced.

4. Design Specifications

4.1 General Design Specifications

- Device must be a game that consists of a ball, a launching mechanism, and 10 bowling style pins set up in a triangular arrangement.
 - The device is meant to be a game with rules and objectives similar to the existing game of ten pin bowling.
- Device must be versatile enough such that a minimum of 95% of the users can utilize this device from their normal wheelchair.
 - All the residents at Seven Hills permanently use wheelchairs so the device must be able to be used by someone sitting in a wheelchair. However, there is no standard design for the wheelchairs so the device must be capable of accommodating wheelchairs of slightly different dimensions and configurations.
- Device must be capable of providing audio feedback pertaining to, at a minimum, the successful release of the ball, and the number of pins fallen.
 - The staff at the Seven Hills Pediatric center said that many of the residents there have reduced vision but can hear fine. Audio feedback will let the residents know when the ball has been released and/or the number of pins that were knocked down.
- Device must be modular.
 - The device must consist of multiple parts such that it is not necessary to move the entire device at the same time.

- No single part of the device may weigh more than 30 pounds.
 - The device should not require multiple people to relocate (no part should be too heavy for one person to lift)
- When disassembled, entire device must be capable of fitting in a closet that is no more than 36 inches deep, 60 inches wide, and 78 inches tall (97.5 cubic feet).
 - The device needs to be able to be stored in a standard sized closet. Each part of the device must be a certain size and configuration such that when certain actions are performed (folding, rolling up matt, etc.) the whole device will fit in the space specified.
- Device must be capable of being prepared for use in no more than 5 minutes by two or fewer people.
 - The set-up time for the device to be used must be kept short, the class periods in the Center are of limited time so the staff should be able to set up the device as quickly as possible to give the residents the as close to the maximum amount of time to play as possible. This setup time does not include relocation of the parts from between rooms.
- Device must be operated with no more than 2 switches. (Or if aiming is manual no more than 1 aiming device and 1 ball release switch.)
 - One of the requirements was to use only one switch to control the device. It is hypothesized that using one switch to control both the ball release and aiming would be too difficult for the residents so one switch should be used to control each action.

- Device must not require normal maintenance more often than once every year.
 - The device must be durable, able to withstand repeated use over a long period of time without breaking, and not require maintenance often. When maintenance is required it should not consist of repairs, but rather actions such as cleaning that require no mechanical tools.
- Device must have an optional, moveable mounting platform for the activation switch(es).
 - It was observed that not all the residents at the Seven Hills Pediatric Center were capable of pushing a switch with their hands so some used their heads instead. The device should allow for this and the mounting platform for the step-by-step switch should be able to move so that the resident can push the switch with his or her head if they so desire.
- Device must have an interface for a “step-by-step” switch to plug into.
 - The designing of this switch is not part of this project, but a method for using the switch to control the device will need to be incorporated.
- Device length must be able to be varied such that the distance from the user to the pins is no less than 80 inches, and no more than 30 feet away.
 - There are different sized rooms in the Seven Hills Pediatric Center where the device will be used so it needs to be able to accommodate these different room sizes, i.e. the length of the alley needs to be adjustable.
- Device must be powered.

- The device should either be powered by a battery, or some sort of outside voltage/current source.
- Time required for Ball retrieval and Pin setup should be no more than two minutes.
 - Currently too much time and effort is spent retrieving balls and resetting pins. This design specification allows for more playing time and less setup time.

4.2 Launching Mechanism Specifications

- Launching mechanism must be able to launch the ball with the ability to choose the trajectory that the ball will take to the pins.
 - Users must be able to aim the ball, however the amount at which the ball is allowed to miss the pins should be controlled.
- Launching device must be capable of producing a ball velocity of no less than 1.5 feet per second, and no more than 25 feet per second.
 - The ball must have enough force when it hits the pins to knock them down, since the ball is a fixed mass it needs to be traveling at a minimum speed to knock down the pins. Yet, too fast of a velocity could present a safety hazard as well as possibly causing damage to pins or any sort of backstop.

4.3 Specifications for a Ball Retrieval Mechanism

- Ball retrieval must attain control of the ball within 10 seconds of the ball hitting the pins.

- The ball retrieval process should be quick and efficient. It should cut down or eliminate the need for a staff member to find, bend down, pick up the ball, and return it to the launching device.
- The ball return will consist of a chute running the length of the alley.
- The ball catching device must control the location of the ball after it hits the pins.
 - This will allow the time required to retrieve the ball to be minimized because it will be in a set location.
- The ball catcher must be controlled automatically requiring no input from the user to begin and end operation.

4.4 Specifications for an alley (if one is required)

- Alley must remain flat when in use (99% of surface must be parallel to the floor).
 - The alley should not change the direction the ball is traveling to any large extent.
- Alley must have device (bumpers) which keeps the ball from rolling off of the sides of the alley.
 - Ball should remain on the alley for the length of the alley, and standard bowling gutters will not be incorporated into the design.
- The alley's length must be adjustable, to no less than 6 feet long but no more than 30 feet.
 - The adjustment of the length of the alley is likely the only adjustment required when optimizing the game for multiple rooms.

4.5 Specifications for a backstop

- The backstop must be able to contain the ball and all of the pins after the pins are knocked down.
- When the ball strikes the backstop at full speed, the backstop cannot travel backwards more than 1 inch per roll on a clean tile floor.
- The backstop must be able to be folded into a smaller package and latch to ease moving.
- The backstop should have a method to ensure that it does not tip over when it is struck with a ball at full speed.

-There should be some sort of supports to prevent the backstop from tipping.

4.6 Specifications for a pin base

- Pin base must have places for 10 pins to sit in a standard bowling arrangement, and measures should be taken to ensure that pins can be setup more easily than on a flat piece of paper.

-There should be holes for the pins to sit in, or some other way to ease pin setup.

- Pin base must have electronic components underneath to provide audio feedback.

-The electronics should be able to tell the number of pins that got knocked down.

- The ball should not rise off the surface of the pin base until it reaches the end or edge of the pin base

-The ball shouldn't "jump" while it is on the pin base.

5. Preliminary Design

5.1 Design Descriptions for a Ball Launcher

Idea 1

An idea that addresses the aim-ability of the ball launching sub-system of the design is to have a ramp with multiple slots which the ball will travel down (Figure 9). The idea is that the aiming device needs to be able to be used by someone with the mental age of a young child. This will allow a simple system where the resident will simply choose which slot they want the ball to go down to hit the pins. For example, if there is one pin standing on the left with respect to the user, then they would place the ball in the left-hand slot.

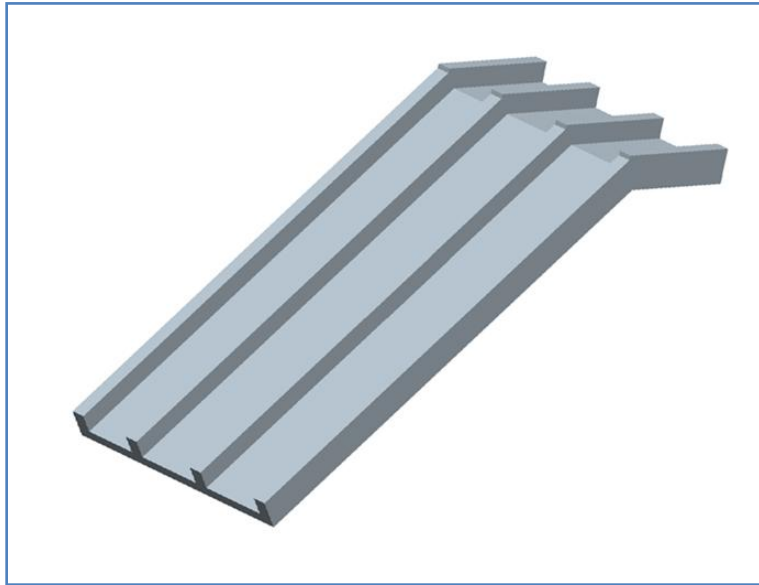

Figure 9: Sketch of Proposed Ramp Idea 1

Idea 2

This ball launching device consists of a tube-like piece of material that the ball starts out in initially while it waits to be released. The ball will need to be placed here by a staff member. This tube would likely be made out of a single piece of PVC pipe cut in half. The ball will be stopped by a rotating arm that will release the ball when the buddy switch is activated. The ball will then roll down the length of this PVC pipe and land in the resident's launching platform. The launching platform will be a wooden box with the bottom angled back toward the resident to ensure that the ball is launched by the resident and not accidentally launched by the release mechanism. The resident will then push the ball onto the ramp, which has raised sides so the ball will not fall off, and the ball will be accelerate it until it reached the alley (Figure 10).



Figure 10: Sketch of Proposed Ramp Idea 2

Idea 3

This design (Figure 11) involves a ball launcher that sits on the floor and uses a spinning wheel powered by an electrical motor to propel the ball towards the pins similar to a baseball pitching machine. To load the machine, a ball is placed on a hinged plate behind the spinning wheel. When a resident presses his/her button, a solenoid pushes the plate up allowing the ball to

roll towards the wheel and out the chute. The major advantage of this design is that a ball return could easily be attached to the opening for a completely automated system. The main disadvantage is that the spinning wheel and motor would present some degree of constant noise during game play.

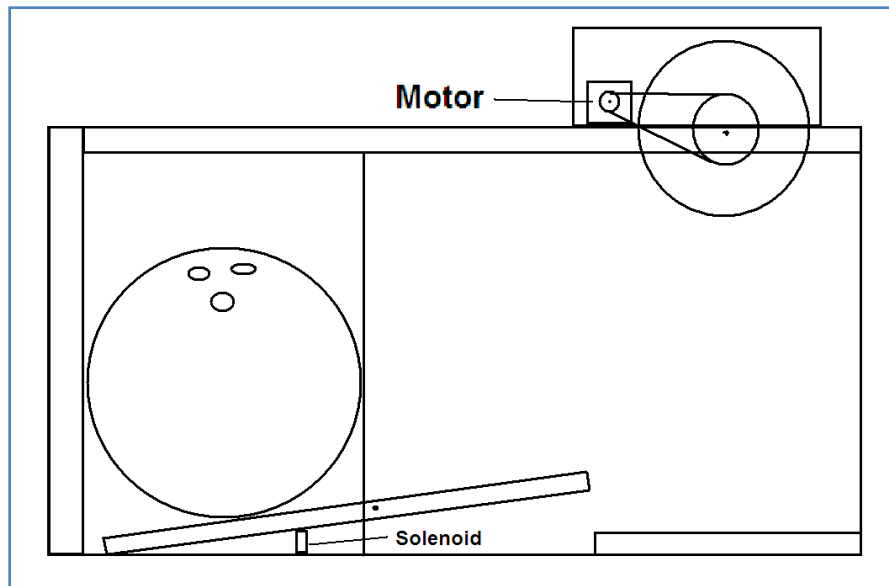

Figure 11: Side View Sketch of Ball Cannon Design

5.2 Design Descriptions for an Alley

Idea 1

One idea is to have a mat-like device (Figure 12) which would allow the bowling ball to travel between the launching device and the pins without going over any sort of lip or edge. This would be a simple sheet of flexible material, like vinyl, which can be unrolled to use and rolled back up to be stored. The long edges, or sides of the alley, would have lips to keep the ball from

rolling off. There would be multiple sheets of set length which would make the overall length of the alley adjustable by using different numbers of sheets.

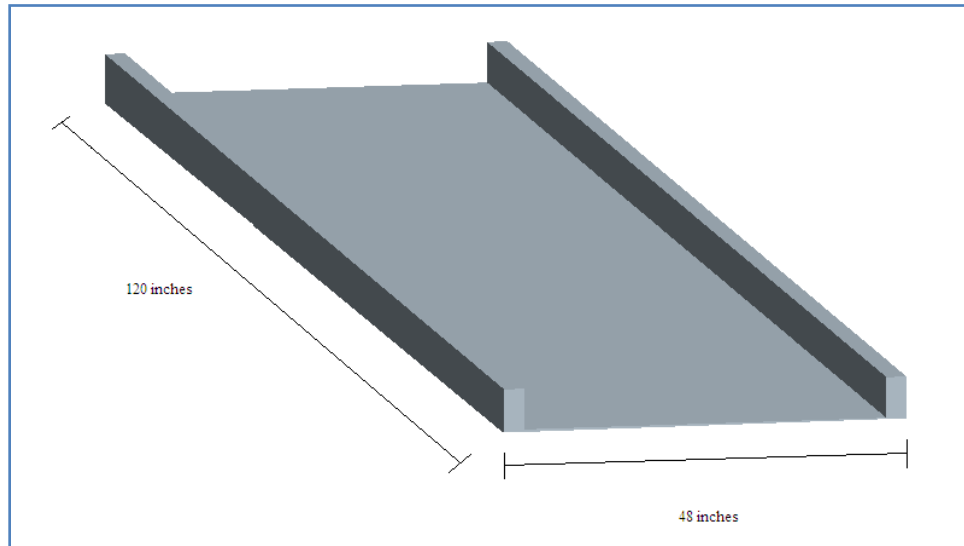

Figure 12: Sketch of Proposed Alley Idea 1

Idea 2

Another idea is to use a “railroad track” like design for the alley (Figure 13). Slats of material laid perpendicular to the alley would be held together by strips of cloth running the length of the alley. The slats would be spaced apart so that the whole device could be rolled up. However, even with the slats placed close together, a lot of bumps would be produced on the top surface of the alley which the ball would have to roll over. The length would be adjusted using the same method as idea number one.

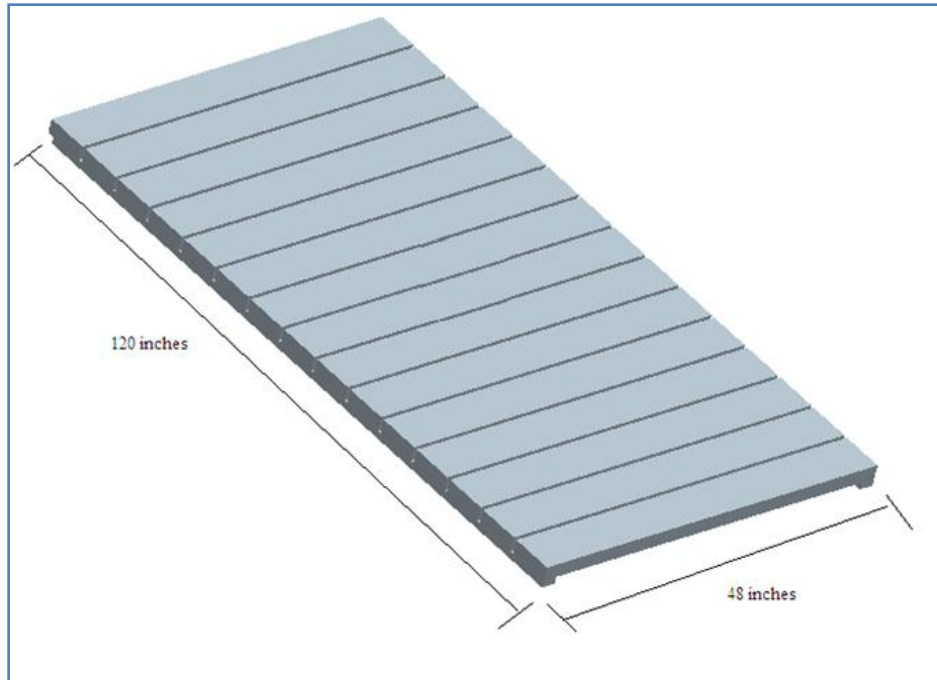

Figure 13: Sketch of Proposed Alley Idea 2

Idea 3

This alley idea (Figure 14) will have sides running along the length of it to keep the ball on the alley, and material below the alley to keep it suspended higher than ground level. At the end of the alley there will be ten holes sunk a little below the surface of the alleyway in order to aid in pin setup. These holes will ensure that pins are set in the correct location every time, and are intended to reduce the amount of time required for pin setup. The material that this alley idea is made out of is not very important for the design, only that the material is capable of meeting the functions required of it. One proposed material is wood. There are some reasonably light forms of plywood that could easily be used to build the alley.

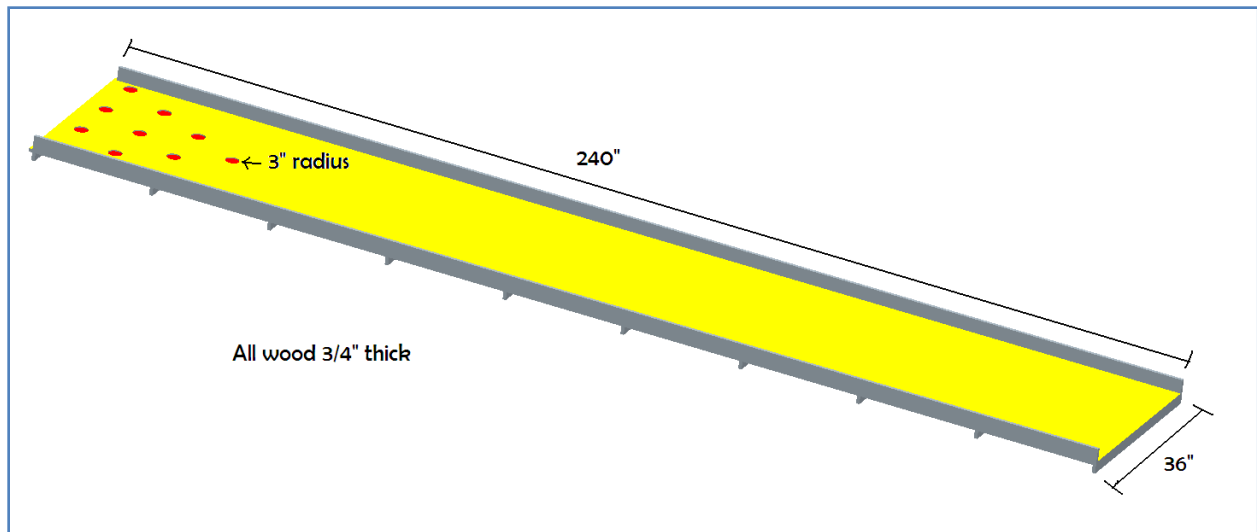

Figure 14: Sketch of Proposed Alley Idea 3

Idea 4

For this design, the alley floor would be made out of a vinyl material that could be inflated while the game is being played. It would consist of multiple tubes running the length of the alley, and then a layer of material covering them to provide a smooth bowling surface on top (Figures 15 and 16). The main advantages of inflating the alley floor is that it provides a means to raise the bowling surface, which might be required for a pin setting mechanism. It also allows for extremely compact storage for such a bulky component of a bowling alley. It could be inflated by any generic inflatable mattress pumps. It would also have larger inflatable tubes running along the sides in order to provide bumpers so that the ball stays in the alley. An alternate design of this would eliminate inflatable tubes running along the bottom of the alley and simply have the two inflatable bumpers running along the bare floor or with a single layer of material for an alley floor.

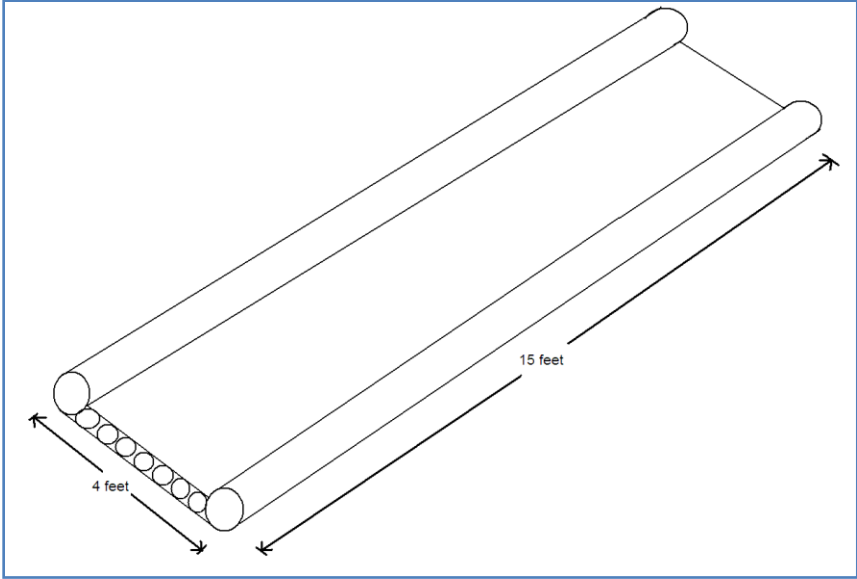

Figure 15: Sketch of Proposed Alley Idea 4

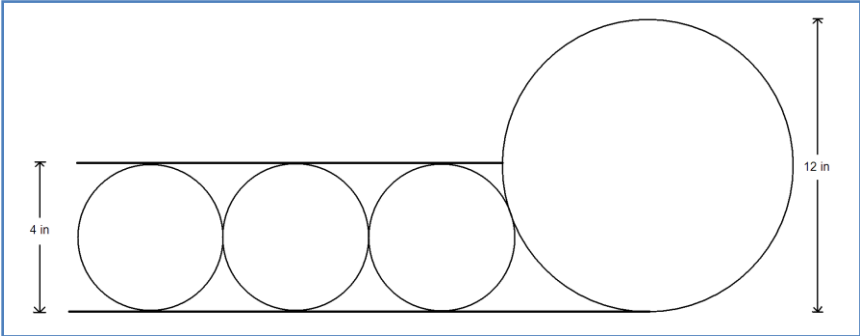

Figure 16: Detail of Proposed Alley Idea 4

5.3 Design Descriptions for a Ball Return

Idea 1

The purpose of the ball return is to bring the ball to a location near where it will be loaded onto the launching mechanism. This is intended to reduce the time required to locate and load the ball.

The first part of this ball return idea (Figure 17) is an inclined surface that is used to funnel the ball from the end of the alley into a valley where it will remain until moved by an outside force. A paddle wheel is the mechanism that will supply this outside force. The paddle wheel will rotate and push the ball along an inclined ramp to the top of a piece of PVC pipe. The PVC pipe will provide a path for the ball to roll along until it finally arrives in a box. This box will be the resting place of the ball until a staff member picks up the ball and places it on the launching mechanism.

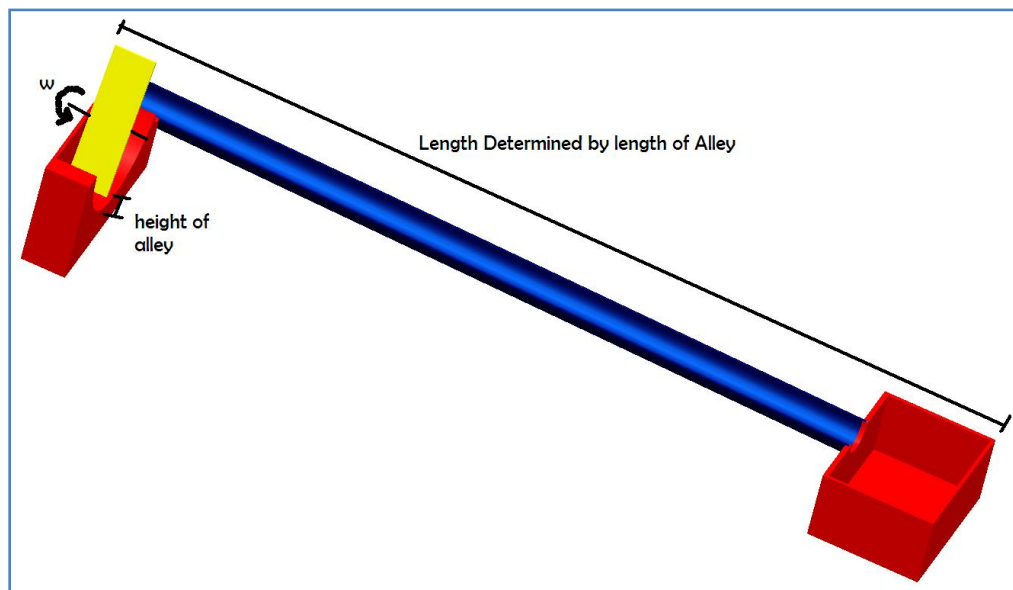

Figure 17: Sketch of Proposed Ball Return Idea 1

Idea 2

This idea is primarily intended to collect the ball after it has rolled down the alley and knocked over the pins (Figure 18). The design for this sub-assembly assumes and depends on there being a raised alley. The main idea is to catch the ball after it has rolled past the pins and redirect it to another location where a staff member can pick it up and return it to the launching mechanism. There are no moving parts on this design; it uses the momentum the ball will have from the launching mechanism and gravity. The ball will travel past the pins and fall into a sloped trough. The ball will then follow the slope of the trough and roll into the basket where it can be picked up by a staff member. The device will have a vertical panel in the back to keep the ball from rolling out of the trough.

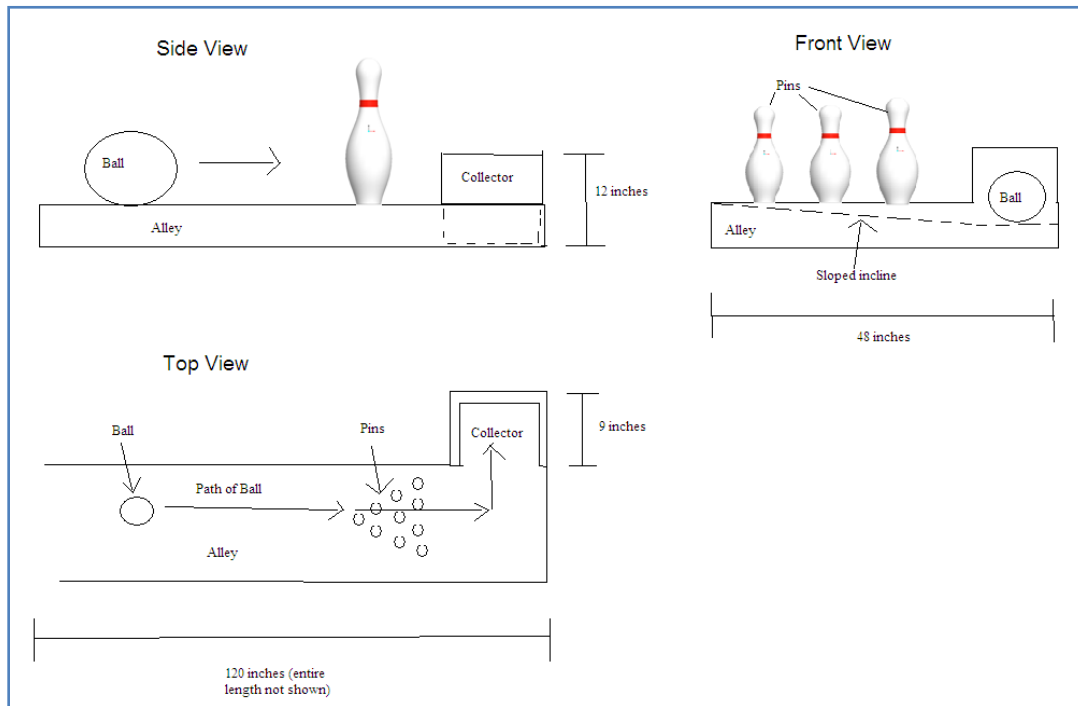

Figure 18: Sketch of Proposed Ball Return Idea 2

Idea 3

This design uses PVC tubes of varying diameter inserted within one another. Each would be about six feet long for storability with the largest being about 11 inches in diameter (Figure 19). The tubes would run the length of the alley on the bare floor. The main advantage of this design is that it can accommodate different room sizes by adjusting its overall length of the tubes. Also, since they are hollow, a ball return component can be integrated to allow the ball to travel inside the tubes back to the player.

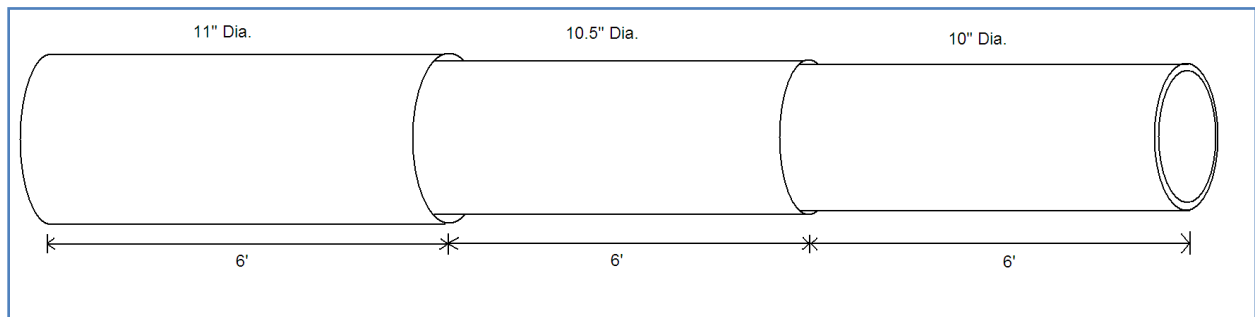

Figure 19: Sketch of Proposed Ball Return Idea 3

5.4 Design Selection

The most relevant aspects that were considered while narrowing down a final design were primarily ease of use by the staff, portability, and storability.

<i>1=unfavorable 5=favorable</i>	Cost of materials	Estimated weight/portability	Estimated reliability	Improvement over original component	Feasibility / usability by staff	Electro-mechanical complexity
<i>Importance (.1-1)</i>	<i>x0.1</i>	<i>x1.0</i>	<i>x0.8</i>	<i>x0.9</i>	<i>x1.0</i>	<i>0.3</i>
Multi-lane ramp	3	2	5	4	5	5
Ramp w/ extra reservoir	2	2	3	2	3	2
Ball cannon	4	5	4	4	3	1
Thin mat alley	4	4	5	1	3	n/a
“train track” alley	3	2	2	2	2	n/a
Rigid wooden alley	2	1	3	2	1	n/a
Inflatable alley	4	4	1	2	1	n/a
Paddle wheel ball return	2	4	1	5	5	2
Sloped ball catcher	4	5	5	3	5	5
Telescopic bumpers	5	4	3	4	2	n/a

<i>1=unfavorable 5=favorable</i>	Power consumption	Size	Collapsibility/storability	average	rank
<i>Importance (.1-1)</i>	<i>x0.5</i>	<i>x0.8</i>	<i>x1.0</i>	-	-
Multi-lane ramp	5	3	3	2.70	1
Ramp w/ extra reservoir	4	4	2	1.91	2
Ball cannon	1	5	3	2.56	3
Thin mat alley	n/a	3	5	2.81	1
“train track” alley	n/a	1	5	1.93	3
Rigid wooden alley	n/a	1	2	1.31	4
Inflatable alley	n/a	2	4	1.94	2
Paddle wheel ball return	3	3	3	2.44	2
Sloped ball catcher	5	4	3	3.03	1
Telescopic bumpers	n/a	2	3	2.44	2

Table 1: Design Table Used in the Design Selection Process

Overall, the final designs for the components were fabricated by combining favorable aspects from each of the preliminary designs. The solenoid activated release was combined with the multi-lane ramp with a gate that could be dropped and reset at the push of a button. The raised pin base was joined to a slanted trough behind the pins. Through careful thought, it was decided to eliminate the concept of an alleyway primarily for the fact that the staff will need the space open between the ramp and pins to move themselves and the residents around the room. An alley also proves unnecessary since all the floors in the Center are smooth tile, not to mention the sheer bulk of moving and storing an alleyway. However, an optional, independent ball return chute will run the length between ramp and pins. This will become useful to the staff if they decide to set the game up beside a wall or if the distance between pins and ramp is large.

6. Final Designs/Prototypes

6.1 Launching Ramp

The design for the launching ramp incorporates a simple sloped plane with guide rails near the top. The intent is to deviate from the common ramp design of having two rails for the ball to roll down and the user would aim by turning the ramp altogether. The design (Figure 20) has multiple chutes running parallel with each other in which the user chooses which one to roll the ball down corresponding to which area of the pin set he/she wants the ball to knock over.

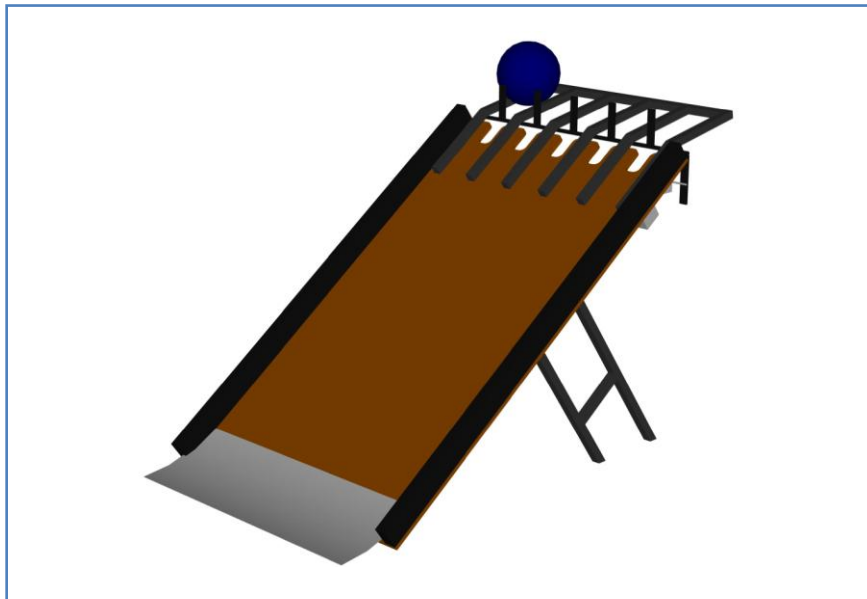

Figure 20: Ramp General View

If the user wants to roll the ball through the center of the pins, then he/she would place the ball in the center chute. If the user wants to hit the outside right pin, then he/she would place the ball in the right-hand chute, etc. The major advantage to this game play is that it gives a more direct interface for the user to decide how the ball should be aimed. With a single ramp lane being rotated ± 5 degrees, it is difficult to decipher exactly where it is pointing, especially if the

user has poor eyesight. The new design's simplification allows the user to choose more exactly where the ball will roll. Another issue with the single chute ramp is that the ball does, in fact, roll down a well defined track. This allows for the ball to hit the same pins in the same manner every frame as long as the ramp is pointing in the same direction, and this leads to a repetitive experience for those playing the game. Therefore, the multi-lane design has various chutes, but these chutes only guide the ball at the top section of the ramp. The ball then rolls freely down the inclined plane, able to naturally deviate slightly from its original path. This gives a small yet noteworthy randomness in the final path of the ball to keep the game interesting but nevertheless skill oriented.

The design has a total of five lanes to choose from which gives enough choice for variety but not too many to make the game unnecessarily elaborate or physically oversized. Each lane has a gate attached to a rod that rotates, allowing the gates to drop, releasing the ball down the ramp. The gate is controlled by a solenoid to unlatch a lock that holds the gate in the upward position. Three standard 9V batteries are connected in series to produce 27V. The batteries are then connected to a master on/off switch which is then connected to a 1/8 inch jack input for a universal button to be connected to. The jack is then connected to the solenoid and finally back to the batteries (Figure 21).

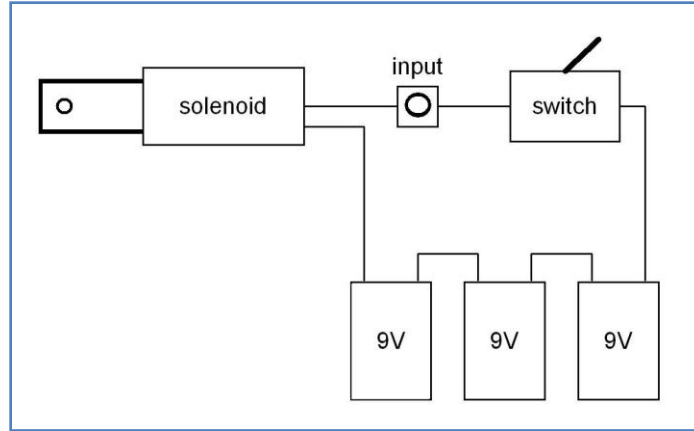

Figure 21: Schematic of Gate Mechanism Electronics

The Seven Hills Pediatric Center has many different large buttons for the residence to use in daily activity; some which even make sounds when pressed. These buttons all have a wire with a 1/8 inch jack on the end that can plug into this ramp design, thus allowing for the residents to use a familiar interface that they are used to. When the master switch is on and the button is plugged in and pressed, the electrical circuit is completed and the pulling solenoid contracts. This is connected to a standard locking gate latch which unlocks a swing arm connected to the gate pivot rod, allowing the gate to drop. The swing arm and gates are balanced so that when the ball is pressed against the gate, it will push it down when unlocked. Yet, if the ball is not present, then the weight of the swing arm will cause it to swing down and relock itself in the gate-up position (Figure 22).

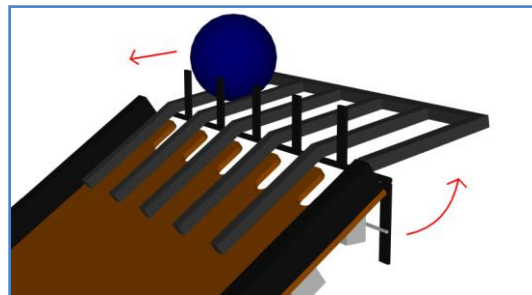

Figure 22: Detail of Gate Swing

The actual dimensions of the ramp have a footprint on the ground of 36 inches wide by about 48 inches long. Simple trigonometry indicates that the ramp surface will be about 60 inches long. The angle of the ramp is 35 degrees from the ground, and the angle of the rails at the top of the ramp is 10 degrees from parallel to the ground (Figure 23). Through measuring various wheelchair heights, we determined a clearance of 34 inches to be adequate for the chairs to roll under the metal frame.

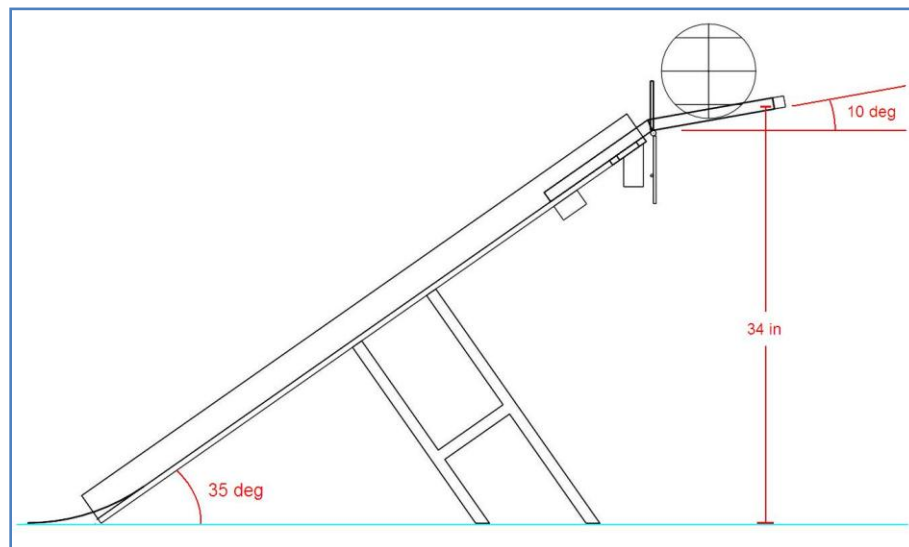

Figure 23: Side View of Launching Ramp

Folding card table legs are attached underneath on each side to allow for wheelchairs to be rolled underneath unobstructed. At the bottom forward edge of the ramp, a curved piece of sheet metal is attached in order to give a smooth transition from incline to floor. Furthermore, two short walls run along the sides of the ramp so that the ball doesn't accidentally fall off the sides.

6.2 Pin Base

The design of the pin base is independent (free-standing) such that it does not need to be used in order for a simple game to be played. The pin base is constructed of plywood, Masonite, and $\frac{3}{4}$ inch pine boards. There are two major sections to the pin base that lock together to be one unit. These two parts are a main base and a ramp leading up to the base. The entire base has a $\frac{3}{4}$ inch frame running around the outside, and on top there is plywood and Masonite. In the Masonite, there are ten holes cut in a triangular pattern such that the distance from the center of any one hole to another is one foot.

The ramp leading up to the pin base is curved such that there is a smooth transition between the ground and the beginning/end of the ramp. Calculations were performed to determine the length of the ramp required for the ball to not leave the ramp assuming a modified sine profile. These calculations can be found in appendix A.

Underneath the pin base, there are electronics that output a signal to a $\frac{1}{8}$ inch audio jack when pins are knocked down. There are holes through the base for the wires and switches to be placed. A rendering was made of the pin base using ProEngineer (Figure 24).

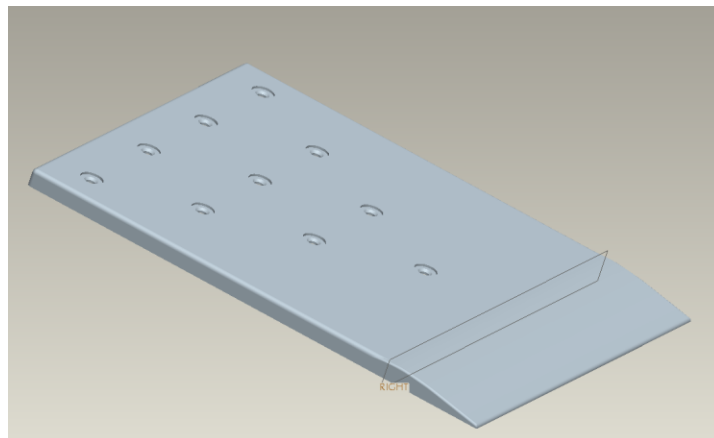

Figure 24: CAD Model of the Pin Base

6.3 Backstop/Ball Catcher

The design for the backstop consists of two separate parts, the ball catcher to trap and redirect the ball, and the backstop panels to contain the ball and the pins. The two parts function differently but both serve the same overall purpose; to stop the forward momentum of the ball and make it easier and more efficient for the attendants to return the ball to the launching ramp. The two parts are separate and independent from one another, but the ball catcher itself is designed to work optimally when used with the backstop panels.

6.3.1 The Ball Catcher

The ball catcher part of the backstop is a simple mechanism which traps the ball and redirects it to a location where it can be easily retrieved every time the ball is rolled. The catcher (Figure 25) consists of two sloped inclines that run perpendicular to each other. The purpose of the rear incline is to redirect the ball to one side or the other. The incline can be tipped to one side or the other (left or right) depending on the users' preference. There are slots on either end of the trough where the bottom part of the incline fits into and dowels above which the higher end of the incline rests on to create a sloped surface. The bottom slots are located so that the lower end of the incline will be one inch from the floor. This leaves 5 inches of wall to stop a 4 inch radius ball. Once the ball rolls into the trough it will roll down the incline until it comes to rest against the wall of the trough. The trough is 8.5 inches wide, 6 inches high and 46 inches long. The front feature of the trough is a sloped ramp which the ball travels up to ensure that it reaches the six inch height of the trough. This ramp is sloped at a 24 degree angle from the ground in order to provide as gradual of a slope as possible, yet still maintaining an overall shallow depth for the component. See Appendix B for exact dimensions of this piece.



Figure 25: Ball Catcher Prototype

6.3.2 The Backstop Panels

The backstop panels are meant to form a barrier which prevents the ball from rolling past and also containing the pins that are knocked down. There are three panels of identical dimensions, 16 inches high and 48 inches wide, which are connected by hinges (Figure 26). The hinges enable the whole part to fold up making it storable. The panels fold out into a rough U shape which surrounds the trough and pin holder parts when in use. When being put into storage mode (Figure 27), the panels are folded up in a compressed Z formation of 48 inches wide and 7 inches thick. Supports are attached to the back of each panel to prevent the part from tipping over when hit by the ball. These supports are attached by hinges and also fold in to make storage easier. There are two supports on the middle panel but only one on each of the side panels. This was done to reduce the weight as only the middle panel is directly hit by the ball and the side panels just prevent the pins from rolling around the room after being knocked down. On the bottom of each panel and the supports are rubber feet which provide frictional force to counteract

the force of the ball hitting the panel and keeping it from moving back from the force of the hit. A strap was also attached along the center panel to ease transportation, and a latch was incorporated to prevent the panels from opening while being moved. For exact dimensions of this piece, refer to Appendix B.



Figure 26: Backstop Panels in Operating Position



Figure 27: Backstop Panels in Stored Position

6.4 Ball Return

The design for the ball return is independent (free-standing) such that it does not need to be used for a simple game to be played. The track for the ball to roll down is constructed of PVC piping, the ribs that hold up this track, and the box at the end would be made of wood. The ball return system is made in components such that it is very modular, and the components will be secured to one another when set up. There are optional sections to add in the middle to accommodate for different room sizes.

The operation of the ball return system consists of a user placing a ball on the raised beginning of the track, thus providing initial potential energy. After the ball is placed, it then rolls down an incline and the potential energy turns into kinetic energy. The ball then rolls along the entire length of the track, and eventually falls into the box at the end where it stays until it is needed.

The ball return system has been intentionally designed to be independent from the rest of the systems. In this manner, the staff at Seven Hills has the option of utilizing the ball return, but the bowling game will not require the use of it. The ball return system is largely recommended for longer distances, since it may be easier to simply move the ball manually than to set up a short ball return (Figure 28).

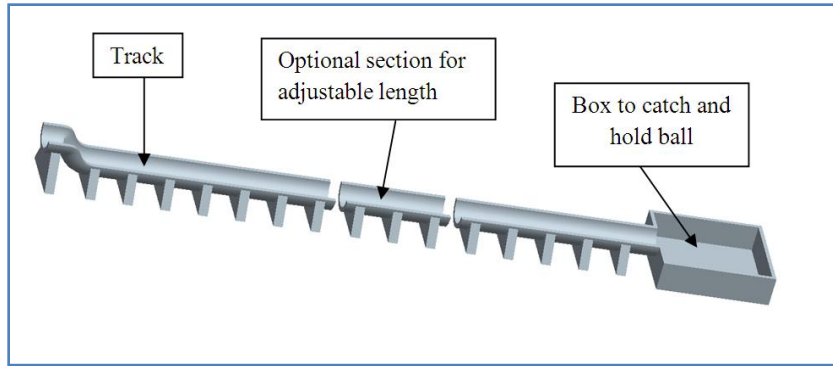

Figure 28: Ball Return CAD Model

The prototype ball return system consists of a piece of PVC at the beginning installed at an angle, several optional sections to be put in of varying length, and a detachable box at the end. The system is connected via latches similar to those found on tool boxes (Figure 29).

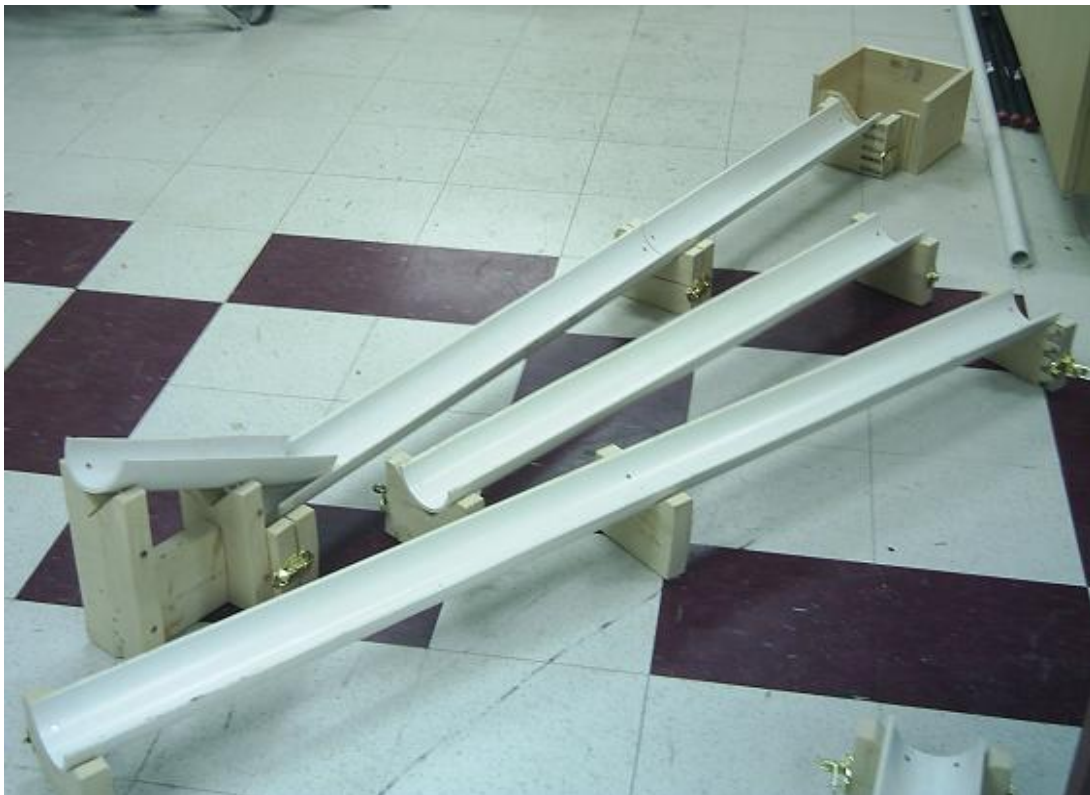

Figure 29: Ball Return Prototype

7. Manufacturing

7.1 Launching Mechanism

The construction of the ramp assembly consisted primarily of wood and steel. The main ramp plane is $\frac{1}{2}$ inch plywood with a layer of $\frac{1}{8}$ inch Masonite glued on top for smoothness. Two 2x3 wood stock pieces (Figure 30, part 1) are screwed along the sides to act as rails for the ball and for structural support. Five finger-like notches (Figure 30, part 2) are cut out along the top edge of the ramp plane for the gate to drop down through. The top metal frame (Figure 30, part 3) was constructed by cutting 1x1 inch square steel tubing to the correct lengths and angles, then welding and grinding the joints smooth.

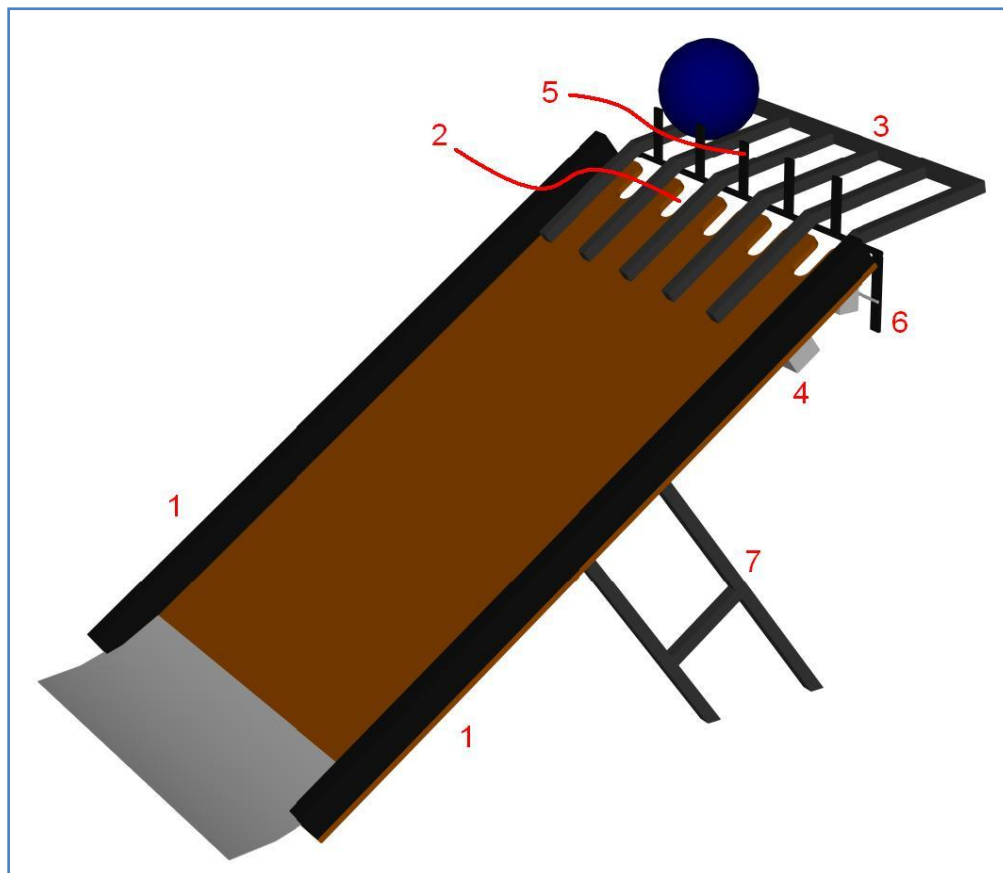

Figure 30: General View of Launching Ramp

Attention was paid to the ends of the rails where the ball will leave them to continue down the ramp in terms of making them all linear perpendicularly to the ramp. This ensured that the ball's trajectory won't skew when it leaves the rails (figure 31).

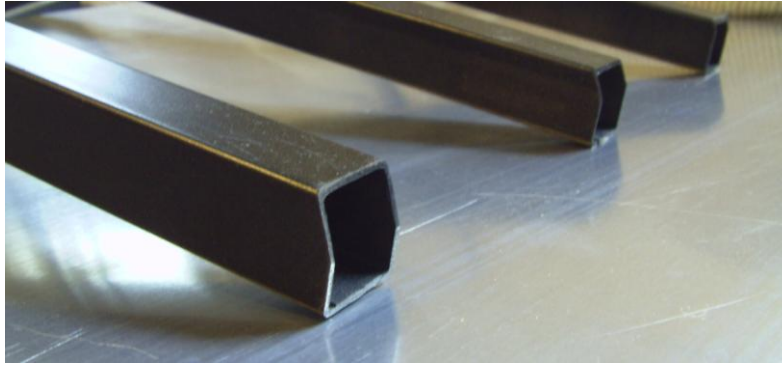

Figure 31: Detail of Rail Ends

Holes were drilled in the rails to connect them to the main ramp by drilling a hole large enough for the screw head to pass through on the top face of the rail, then drilling a hole just large enough for the screw thread to pass through on the bottom face of the rail (Figure 32).



Figure 32: Screw Hole Detail

These screws pass through the plywood plane and into a 2x3 running the width of the ramp near the top (Figure 30, part 4). This also acts as a support to add rigidity to the ramp. The

gate (Figure 30, part 5) was constructed simply by welding 1 x ¼ x 4 inch long pieces of steel to a ½ inch rod running the width of the ramp. This was attached on the inside of the kink in the metal frame with open-ended nylon electrical clamps screwed to the frame with self tapping screws. A sparing amount of grease was added to reduce friction in the rotation of the gate. The latching component (Figure 30, part 6) was made out of a regular house outlet box modified to hold a pull-solenoid with about 1 inch of travel. This is directly linked to the receiver part of a gate latch, which is also attached to the outlet box and exposed to allow the gate to latch into it (Figure 30).



Figure 33: Latch Detail

Wires are run from this box to a separate plastic box next to it which houses the batteries, master switch, and input jack. The legs (Figure 30, part 7) used are standard 30 inch folding table legs. These were attached to lie flat with the ramp plane, which means that they are at an angle to the ground (Figure 34). This was solved by cutting one of the feet down on each leg so that all four sit evenly on the ground.



Figure 34: Cut Leg Detail

7.2 Pin Base

The first part of the pin base that was manufactured was the top piece. It was made out of $\frac{1}{4}$ " Masonite, and $\frac{1}{2}$ " plywood. The Masonite and the plywood were not cut together as it was very hard to keep the two lined up.

After the wood for the top of the base was cut, the ten holes for the pins to sit in were cut out. The holes were then sanded to a finalized diameter. After this, $\frac{3}{4}$ " thick wood was used to construct the frame under the pin base. First the wood was cut to width, then the wood was cut to length.

Assembling the pin base was the next step. Each piece was drilled and screwed together starting with the top and the frame. Then more frame pieces were added until there was a complete frame under the backstop. Two extra pieces of wood were cut and put in the middle of the backstop as extra support. They were made in the same way as the rest of the frame.

The ramp was built next. This ramp was built using the leftover pieces of Masonite and plywood from the first part of the base. The wood was cut to size, then triangular pieces of $\frac{3}{4}$ inch pine boards were cut to mount the ramp to. The pieces were then drilled and screwed together. The final part of building the pin base was adding the latch to the sides of the ramp and the base so that the two pieces could latch together.

7.3 Backstop Panels

The three backstop panels were made by cutting a piece of quarter-inch plywood to three identical rectangles of dimensions 12 x 48 inches (Figure 35, part 1). Next a 2x4 was cut down to three 48 inch sections. These were then attached, with screws, to the plywood rectangles with the long edges flush with each other (Figure 35, part 2). Triangular supports were cut from $\frac{3}{8}$ inch plywood by first cutting the plywood into square blocks eight inches on each side (Figure 35, part 3). Next, the braces were cut from another piece of plywood and screwed to the angled side of the supports (Figure 35, part 4). One side of a small hinge was then added to the vertical edge of the support and the other side was attached to the 2x4 on the panel. Two three inch lengths of 2x4 were cut and hinges added to each end of the blocks. The opposite ends of the hinges were screwed to the ends of the 2x4's on the panels. A strap was added to the 2x4's on the left-side panel and the middle panel so that when folded up the strap goes across the top of the panels. Refer to Appendix B for detailed drawings and dimensions.

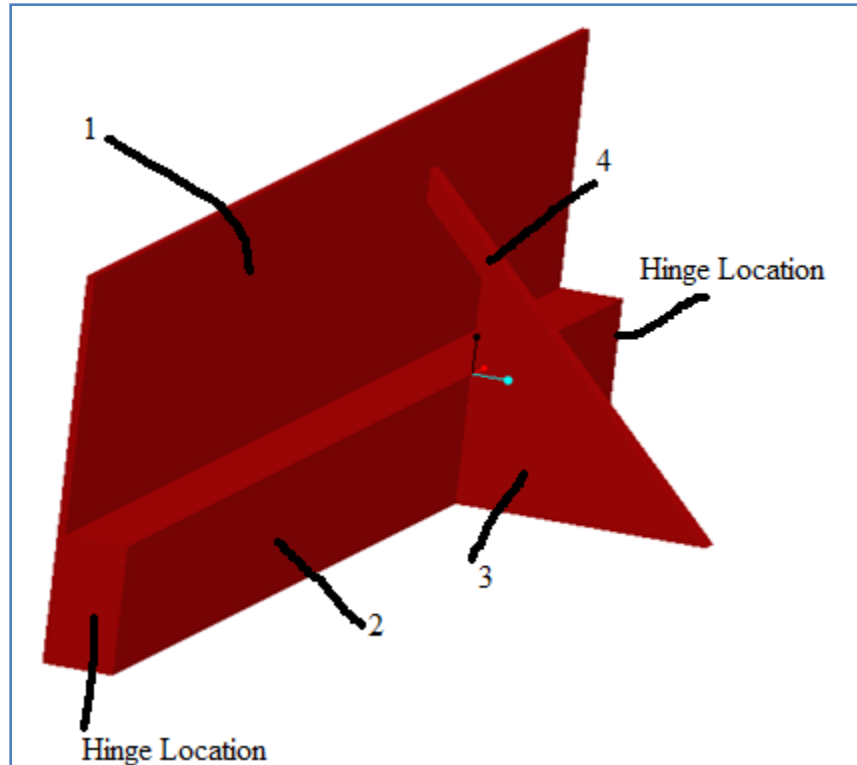

Figure 35: Backstop Panel with Support

7.4 The Ball Catcher

The ball catcher was made by cutting two pieces of 2x8 inch wood to the required angle profile (Figure 36, part 1). Next, two pieces of wood were cut to a length of 46 inches (Figure 36, part 4). These were then attached to the sides of the two profile pieces to form the walls of the trough. Two cleats were added to one side of the bottom of the trough part to secure the plywood incline slope on one side (Figure 36, part 5). A dowel was then added above the cleats and at the midpoint (Figure 36, part 3). This procedure was repeated on the opposite end of the trough. The next step was to make the support pieces for the front slope, which were then attached to the side of the trough (Cannot be seen in 36, refer to Appendix B). A 46 x 13 inch rectangle was cut from quarter-inch plywood to form the surface of the front slope (Figure 36, part 2). This was then laid down on the sloped part of the profile pieces and screwed down to the profile and the support

pieces. The screw holes were all countersunk so that the screw heads would not interfere with the ball rolling over them. Finally, a 44 x 9 inch rectangle (Figure 37, part 1) was cut from quarter-inch plywood and two 1 inch diameter holes (Figure 37, part 2) were drilled to provide a way of lifting the base out of the trough. This piece forms the sloped incline in the trough and is left free so as to remain moveable. Refer to Appendix B for detailed drawings and dimensions.

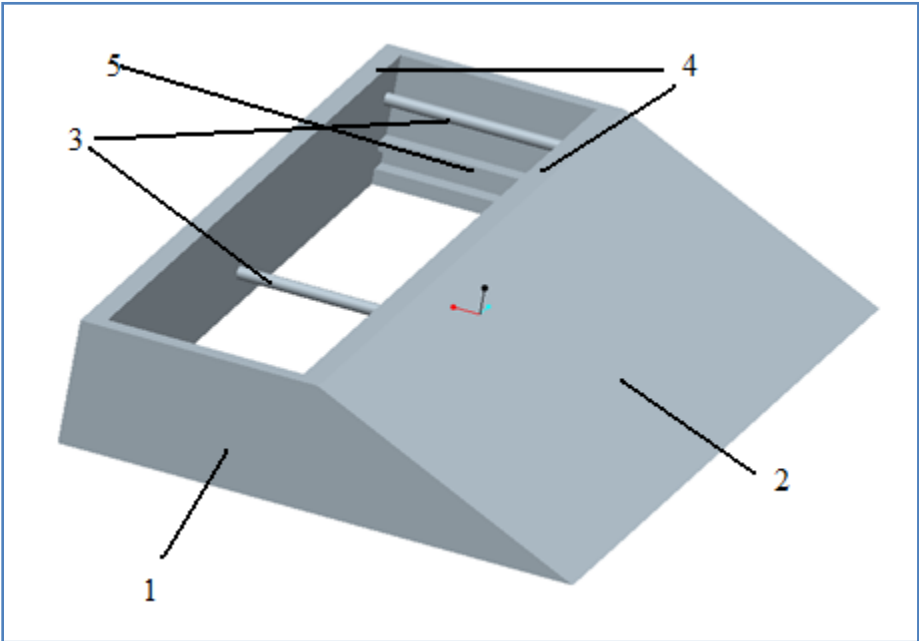

Figure 36: Ball Catcher Without the Incline Slope

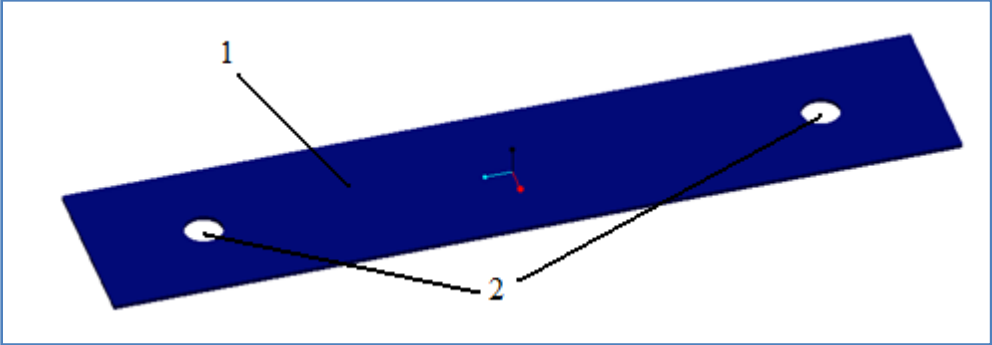

Figure 37 Incline for Ball Catcher

7.2 Pin Base

The first part of the pin base that was manufactured was the top piece (Appendix B, Pin Base, part 1). It was made out of 1/4" Masonite, and 1/2" plywood. The Masonite and the plywood were not cut together as it was very hard to keep the two lined up.

After the wood for the top of the base was cut, the ten holes for the pins to sit in were cut out. (Appendix B, Pin Base, part 2) The holes were then sanded to a finalized diameter. After this, 3/4" thick wood was used to construct the frame under the pin base (Appendix B, Pin Base, part 3). First the wood was cut to width, then the wood was cut to length.

Assembling the pin base was the next step. Each piece was drilled and screwed together starting with the top and the frame. Then more frame pieces were added until there was a complete frame under the backstop. Two extra pieces of wood were cut and put in the middle of the backstop as extra support. They were made in the same way as the rest of the frame.

The ramp was built next. This ramp was built using the leftover pieces of Masonite and plywood from the first part of the base. The wood was cut to size, and then triangular pieces of 3/4 inch pine boards were cut to mount the ramp onto (Appendix B, part 4). The pieces were then drilled and screwed together. The final part of building the pin base was adding the latch to the sides of the ramp and the base so that the two pieces could latch together.

7.5 Ball Return

The trough for the ball to travel down consists of PVC pipe that was cut in half (Appendix B, Ball Return, part 1). The PVC pipe was then cut to proper lengths.

The next part of the ball return that was built was the blocks that the trough sits on (Appendix B, Ball Return, part 2). These blocks were made out of 1x6 pine boards. The boards were first cut to an appropriate length. After they were the right length a triangular piece had to be cut out of each block to ensure there is a place for the trough to fit. This was done by making two cuts each at a 45 degree angle.

The blocks and the PVC pipes were pre-drilled and screwed together. The screws used were not wood screws but heavier drywall screws. Everything was pre-drilled to attempt to ensure there was no splitting of the wood since the wrong screws were used.

The next part that was made was the box for the ball to land in (Appendix B, Ball Return, part 3). This box was made of $\frac{3}{4}$ " pine boards. The boards were first cut to length, but no more cutting was required since the boards were of uniform width. They were then pre-drilled and screwed together.

The last big piece to be made was the ramp leading to the ball return (Appendix B, Ball Return, part 4). The first thing that was done was to take a piece of the extra PVC piping and cut off some of the sides and bend the bottom. This was done so that the ramp would "slide" into the first piece of track. After that, more 1x6 was used to build a stand for the ramp to sit on. All of the 1x6 was cut to length then triangular notches were cut out as before, then the wood was pre-drilled and screwed together. Finally the ramp was placed on this and pre-drilled and screwed together.

The final thing that was done to build the ball return was to attach hinges at the same height on every piece. By attaching the hinges at the same height, it was ensured that pieces could be removed or added as needed. This allows for the track to be of adjustable length.

8. Testing Phase 1

8.1 Stage 1: In-house testing for functionality by design team

8.1.1 Ramp

1. Ramp will be laid against a wall to simulate a scenario where the ramp has been stored.
2. Each team member will set up the ramp.
3. The bowling ball will be placed into the left-most starting position.
4. The bowling ball will be launched using a simulated buddy switch.
5. Steps 3 and 4 will be repeated at least 2 times for each starting location until all locations have been tested.
6. Each team member will take down the ramp and replace it against a wall.

8.1.2 Pin Base

1. A member of the design team will place all 10 pins on the cardboard mat that came with the pins to simulate the original game at Seven Hills.
2. The pin base will start by being laid against a wall to simulate a stored base.
3. The same member of the design team will set up the pin base.
4. The same member of the design team will place all 10 pins on the base.
5. The ball will be released from the ramp towards the pin base, ideally knocking down some or all of the pins.
6. The same member who set up the pin base will take it down and lay it against a wall.
7. Steps 1 through 6 will be repeated with each team member.

8.1.3 Backstop

1. The ramp will be set up and pointed towards the intended place to set up the backstop.
2. The backstop will be folded up and placed near a wall, and the ball capturing device will be placed near the same wall to simulate a stored scenario.
3. A member of the design team will set up the ball capturing device and the backstop panels in their proper positions for use.
4. The bowling ball will be placed in the left most starting position on the ramp.
5. The bowling ball will be launched from the ramp.
6. Impact of the ball against the capturing device and backstop will be observed.
7. Steps 4 and 5 will be repeated once for each lane of the ramp.
8. Steps 2 through 6 will be repeated with each team member.

8.1.4 Ball return

1. The ball return will be placed in individual pieces next to each other against a wall to simulate a stored ball return.
2. A member of the design team will set up all the pieces of the ball return to simulate setting up the pin base for the longest alley length.
3. The team member who set up the ball return will place the ball at the top of the return ramp and allowed it to roll the length of the ball return three times.
4. The team member who set up the ramp will take it down.
5. Steps 2 through 4 will be repeated by each team member.

8.1.5 Battery Life

1. Three new 9V batteries will be connected in series to the gate dropping mechanism on the launching ramp.

2. A voltmeter will be connected to the leads of the three batteries.
3. The circuit will be closed briefly 100 times consecutively to simulate multiple presses of a button.
4. The circuit will then be held closed for 10 seconds.
5. Steps 3 and 4 will be repeated; recording number of cycles versus the voltage reading on the unloaded batteries.

8.1.6 Entire Game

1. The entire bowling game will be set up by members of the design team.
2. The game will be played by the members of the design team (Ball will be placed on ramp, launched using a simulated buddy button, retrieved and sent back via the ball return, and the pins will be set back up after 2 balls have been launched from the ramp).
3. The entire bowling game will be taken down by the members of the design team.

8.2 Stage 2: Seven Hills Staff

After sufficient testing for functionality by the project team, the game was brought to the Seven Hills Pediatric Center so that the staff could examine the progress made. It was critical to gain their input on the current design so that any strong and weak points of the design could be exposed in terms of actual usage by the center. This ensures that the final design will not only meet the project team's design specifications, but will also be used frequently by the staff. If an unforeseen flaw is found after completion of the project, then the game will not be used by the pediatric center and the global goal of creating a usable game will be a failure.

The primary investigative matter was how mobile the overall game was for the staff at the

pediatric center, especially for those of petite stature. The area of biggest concern was with the launching ramp in terms of weight. An estimated weight of 60 pounds was examined prior to the visit and castors were planned to be added to ease transportation. However, the staff still showed great concern regarding the mobility of the ramp and concluded that they would sacrifice lane options in order to reduce weight. They decided that two lanes would be sufficient instead of the original five lanes. This would bring the weight down to about 30 pounds with half the width, which is far more manageable for an average staff member to move. On the other hand, they did show great praise for the ability to plug a button into the ramp and let it work by the residence's will alone. Another benefit of using a wired button is that the resident who is bowling could sit to the side of the ramp instead of directly behind it. This gives a wider view of the game play and can give a higher entertainment factor for the resident in that he/she will be in more direct sight of the pins being knocked over, as opposed to being stuck behind a ramp.

Another area of concern was the overall storability of all the game components. At the center, formal storage is at a minimum and the game will have to be stored in any available area that is open. That being said, the staff asked if any components could be reduced in either size/weight, condense-ability, or be rejected altogether. They also mentioned that some components could be stored in an outside building, but this would require staff members having to go out into the weather to retrieve said parts and therefore may not be used.

The ball return and ball catcher seemed unnecessary for basic game play to the staff. However, the room that was used to demonstrate the game in was small compared to other rooms at the facility. Therefore, the ball return was not used to its potential during the visit. It was easy enough for the person retrieving the ball to simply bring the ball back to the launching ramp, but in a larger room the ball return would prove more useful. The ball catcher worked less ideally

than expected in that the ball's momentum was often reduced from striking the pins alone and didn't have enough energy to make it up the ball catcher's ramp. However, the pins used that day were the ones owned by the center and a few ounces of sand had been poured into them to add weight. This was done to lower the center of gravity in the pins and greatly affected the ability for the ball to reach the trough when knocking over a full frame of pins. However, if pins had been knocked over already and the ball rolled over the pin base unopposed, then the ball would be able to retain enough momentum to make it up the ramp and into the trough as designed.

An issue was also noticed when trying to fold the backstop panels to be stored away. The current design accounted for foam padding to be added to the surfaces, but this proved unnecessary in that the wood surfaces were sufficient in stopping the ball. Because of the intended foam addition, the panels folded in a "Z" shape instead of the two outside panels folding into each other towards the center panel in a "U" shape. This made it difficult to see which panel folded which direction. More importantly, if the backstop is in a confined area, then it would be cumbersome to fold and unfold.

Overall, the staff seemed very pleased with what was presented to them. They also noted that painting the components bright colors would be beneficial. The suggestions they gave were recorded and the project team took the game back to WPI to be modified.

9. Redesign and Rebuild

9.1 Backstop

After the initial testing at the Seven Hills Pediatric Center, several features of the Backstop were redesigned. The first was the elimination of planning to put foam pads on the front face of the panels to provide cushioning from the impact of the ball. The Backstop performed well without any foam padding when it was tested both in house and during the testing at Seven Hills and therefore did not need any further damping.

The second feature of the backstop that needed to be redesigned was the hinge mountings which allowed the three Backstop panels to fold up to be stored. The staff at Seven Hills found the three panels to be awkward and confusing to fold up. The panels were originally designed to fold up in a sort of Z (Figure 38). The staff had trouble figuring out which direction to fold each of the side panels to store the part. The Backstop was redesigned to fold out more like a book (Figure 39). A six inch piece of wood was added to allow one side panel to fold over the other panel. This is a much more intuitive procedure for folding up the backstop panels and takes up less floor space as the side panels are only folding in one direction.

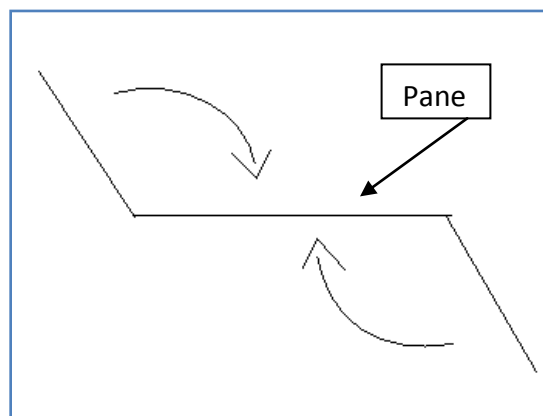

Figure 38: Original Backstop Design

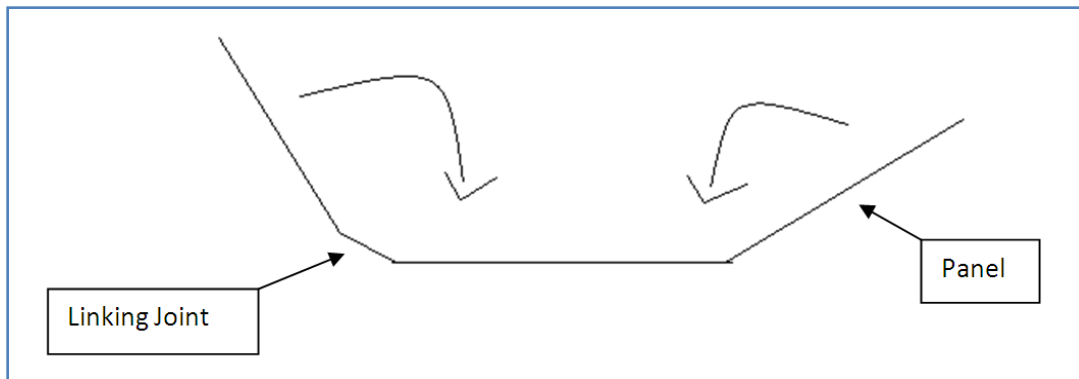

Figure 39: Improved Backstop Design

9.2 Ball Catcher

A problem was observed with the ball catcher when using it in conjunction with the pin base set up with bowling pins on it. When the ball passed through the pins it lost much of its momentum and had difficulty traveling up the ramp on the front of the ball catcher. However, the ball had no difficulty traveling up the ramp when there were no pins on the pin base. Because the ball does not usually travel up the ramp when the game is played normally, it does not perform the function it was designed to and its use is not essential. The ball catcher will be given to Seven Hills to use at their discretion.

9.3 Launching Ramp

The main issue with the Launching Ramp was its width, the original design was for five lanes but the staff at Seven Hills felt that five lanes made the device too large for them to operate. Each lane was six inches wide so the whole device was 36 inches wide altogether. The staff felt that they would not be able to store a device this large and that it was too difficult for them to move. The issue was settled by cutting the whole ramp down to just two lanes. This made the total width of the Launching Ramp 18 inches, which is a much more manageable size for the staff at Seven Hills to move around and to store.

9.4 Pin Base

The Seven Hills staff showed interest in having audio feedback integrated into the pin base. However, due to lack of formal designs, no audio feedback was implemented.

10. Testing Phase 2

In-house testing for functionality by outside sources

Test to be performed by individuals uninvolved with the project:

1. A brief introduction to familiarize the individual with the project will be given.
2. Individual will be asked their age, gender, and height.
3. All pieces of the project will be placed against a wall to simulate a stored position.
4. Individual should move the piece to its intended location and set it up, which should be located no less than 15 feet away from the initial position, and through at least one doorway to simulate relocation of the game.
5. Individual will be asked to evaluate how difficult it was to move each component on a scale of 1 to 5, with 5 being extremely difficult and 1 being relatively easy to move.
6. If a group of two to four people are present, then they will be asked to work together without design team intervention to carry all the pieces from one room to another and set up the game ready to be played.
7. The group will be asked to evaluate how difficult it was to set up the entire game from a stored position in a separate room on a scale of 1 to 5, with 5 being extremely difficult and 1 being relatively easy to perform.
8. The design team will also time the group discretely to attain an overall time for setup by personnel not involved with the project.
9. Individual should place the 10 pins on the original pin mat that came with the pins.
10. Individual should then place the 10 pins on the new pin base.
11. Individual will be asked to rate how difficult/monotonous it was to place the pins on the first mat on a scale of 1 to 5, with 5 being extremely difficult, and 1 being relatively easy.

12. Individual will then be asked to rate how difficult it was to place the pins on the new pin base on a scale of 1 to 5, with 5 being extremely difficult, and 1 being relatively easy.
13. The design team will time the individual discretely to attain an overall time to reset a frame.
14. Individual should then be given the option to play the game.
15. Members of the design team will collapse down the game and return it to its initial position.

11. Results

11.1 In-House Testing for Weight and Dimension

Each component was individually weighed and measured for volumetric dimensions in both stored and open states (Table 2). No single component exceeds the 30 pound limit set in the design specifications. The open volumes are added together to attain an overall open volume, however, the closed volume was physically measured when the pieces were all stored together, and the stored volume is significantly less than the open volume. The stored volume is 52.5 cubic feet is less than the design specification of 97.5 cubic feet.

Component	Weight (lbs)	Open Size (in)	Closed (Stored) Size (in)
Ramp	30	24 x 34 x 44	9 x 24 x 72
Pin Base	24	2 x 40 x 48	2 x 40 x 48
Ball Catcher	20	6 x 23 x 46	6 x 23 x 46
Backstop	27	12 x 60 x 89	10 x 12 x 48
Ball Return	19	11 x 15 x 171	15 x 16 x 80
Totals	120	80.08 ft³	Actual Stored Total= 45 ft³

Table 2: Table of Weights and Volumes (Open and Stored Positions) of All Components

11.2 Battery Life Results

The three 9V batteries were tested in a manner to simulate actual game play. That is, they were installed normally and the game was operated in its intended manner. The test procedure was followed as described in the “testing phase 1” section and was repeated 35 times, to simulate 3500 presses of a button. The voltage observed from the batteries diminished 3.1 volts from 27 volts to 23.9 volts. This allows for ample voltage to still be used to power the solenoid, and it proves that the batteries will not need to be changed until a large number of games have been played.

11.3 Analysis of Outside Testing Results

<i>1=easy, 5=difficult</i>							
Individual part difficulty							
gender	male	female	female	female	female	female	female
height	69in	65in	65in	64in	65in	64in	68in
age	21yrs	21yrs	20yrs	20yrs	22yrs	21yrs	22yrs
Launching Ramp	1.5	3	1.75	3	3.5	2	1.5
Ball Catcher	1	2	2.5	2	3	1.5	1.5
Pin Base	1.5	1	2	2.5	3	2	1.5
Ball Return	3	1	1.25	1	2.5	1	1
Backstop	2	4	4	2.25	3.5	3	2
Pin Setup Original Mat	3	3	5	3.5	2	3	2.5
pin Setup New Mat	2	2	4	2.5	2	2	2

average
2.32
1.93
1.93
1.54
2.96
3.14
2.36

Table 3: Results of Tests Conducted by Testers Unaffiliated with the Project

group difficulty			
group size	3	2	2
overall rating	2.5	3	2
time to complete (m:ss)	2:13	3:20	1:55

Table 4: Group Results of Testers unaffiliated with the Project

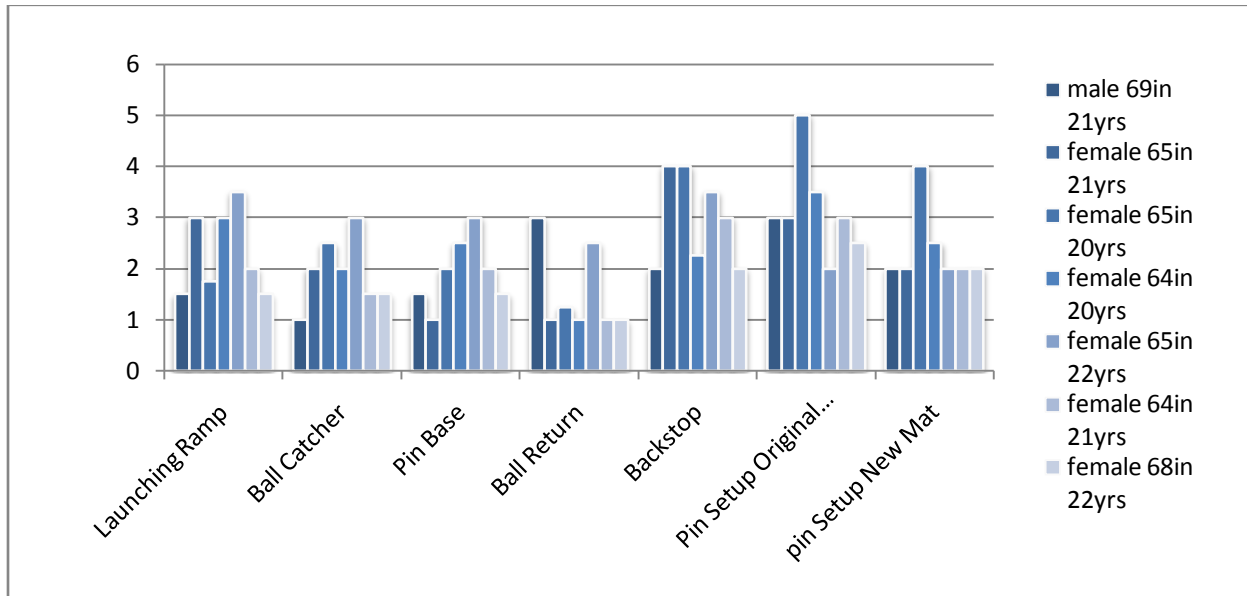

Figure 40: Graph of Outside Test Results

11.3.1 Pin Setup Statistical Analysis

A probability test was performed on the results of the old mat versus the new mat. A 2-sample Z test was used and the probability returned was 6.12%. While these results may not be

statistically significant at $P=0.95$, the results clearly show a trend in the new pin base being easier to set up than the cardboard mat.

11.4 Design Specification Results

11.4.1 General Design Specifications

- Device must be a game that consists of a ball, a launching mechanism, and 10 bowling style pins set up in a triangular arrangement.
 - This design specification was met completely.
- Device must be versatile enough such that a minimum of 95% of the users can utilize this device from their normal wheelchair.
 - Met, due to the single switch activation, users can be placed anywhere near the device and press the switch to operate it, therefore 100% of users who can press a switch can use this device.
- Device must be capable of providing audio feedback pertaining to, at a minimum, the successful release of the ball, and the number of pins fallen.
 - Not met, no audio feedback is given to the users, unless a special buddy switch with audio feedback capabilities is utilized.
- Device must be modular.
 - Met, the device can be taken into many pieces for ease of transportation

- No single part of the device may weigh more than 30 pounds.
 - Met, the heaviest part weighs 30 pounds, and all other parts are lighter. Most parts are significantly lighter.

- When disassembled, entire device must be capable of fitting in a closet that is no more than 36 inches deep, 60 inches wide, and 78 inches tall.
 - Met, when disassembled and stored, the device occupies 45 cubic feet of space.

- Device must be capable of being prepared for use in no more than 5 minutes by two or fewer people.
 - Met.

- Device must be operated with no more than 2 switches. (Or if aiming is manual no more than 1 aiming device and 1 ball release switch.)
 - Met, use of the device requires only 1 switch on the part of the user.

- Device must not require normal maintenance more often than once every year.
 - Unknown.

- Device must have an optional, moveable mounting platform for the activation switch(es).
 - Not met.

- Device must have an interface for a “step-by-step” switch to plug into.
 - Met, jack is located on the electronic box on the ramp.

- Device length must be able to be varied such that the distance from the user to the pins is no less than 6.66 feet, and no more than 30 feet away.
 - Met, the length of the device can be changed from approximately 8 feet to 25 feet
- Device must be powered.
 - Met, three 9v batteries in series.
- Time required for Ball retrieval and Pin setup should be no more than two minutes.
 - Met, the time required for ball retrieval and pin setup is closer to 30 seconds than 2 minutes.

11.4.2 Launching Mechanism Specifications

- Launching mechanism must be able to launch the ball with the ability to choose the path that the ball will take to the pins.
 - Met, there are 2 different paths that the ball can be rolled down.
- Launching device must be capable of producing a ball velocity of no less than 1.5 feet per second, and no more than 25 feet per second.
 - Met, the ramp produced velocities around 10 ft/s.

11.4.3 Specifications for a Ball Retrieval Mechanism

- Ball retrieval must attain control of the ball within 10 seconds of the ball hitting the pins.

- Not met, the ball retrieval does not always attain control of the ball due to loss of momentum from the pins, however the backstop usually retains the ball within its walls, thus making it easier to find.
- The ball return will consist of a chute running the length of the alley.
 - Met, there are multiple chutes that can be attached to change the length of the ball return.
- The ball catching device must control the location of the ball after it hits the pins.
 - Not met, since the ball catching device does not always attain control of the ball.
- The ball catcher must be controlled automatically requiring no input from the user to begin and end operation.
 - Not met, it was determined that meeting this particular design specification would result in other more important design specifications not being able to be met, namely the mobility, and weight of the parts.

11.4.4 Specifications for a backstop

- The backstop must be able to contain the ball and all of the pins after the pins are knocked down.
 - Met, the ball and pins stayed within the backstop all but 2 times in our testing.
- When the ball strikes the backstop at full speed, the backstop cannot travel backwards more than 1 inch per roll on a clean tile floor.
 - Met, the backstop only moves approximately ½ inch.

- The backstop must be able to be folded into a smaller package and latch to ease moving.
 - Met, the backstop folds in a z type pattern, for space saving ability.
- The backstop should have a method to ensure that it does not tip over when it is struck with a ball at full speed.
 - Met, the backstop has triangular trusses that help prevent tipping.

11.4.5 Specifications for a pin base

- Pin base must have places for 10 pins to sit in a standard bowling arrangement, and measures should be taken to ensure that pins can be setup more easily than on a flat piece of paper.
 - Met, the 10 holes are sunk so that there is a lip to ease pin setup.
- Pin base must have electronic components underneath to provide audio feedback.
 - Not met, electronic components were not placed into the pin base.
- The ball should not rise off the surface of the pin base until it reaches the end or edge of the pin base
 - Not met, due to manufacturing difficulty, the ramp designed is triangular, thus producing a sharp corner that causes ball to jump slightly.

Out of the 27 design specifications 19 of them were met. The design specifications that were not met were those pertaining to the pin base electronics, the switch locating platform, the ball locating components, automation of the ball return system, and maintenance. The maintenance design specification was not met because until a year has passed, there is no way to be sure the product did not require maintenance more than twice, however the system was designed such that no scheduled maintenance is required. The automation of the ball return system and the switch locating platforms were intentionally not met, as it was determined that meeting the specifications regarding those sections would add too much weight, and general bulk to the product. The pin base electronics were not built and installed due to lack of time, and the ball catcher did not consistently locate the ball.

The design team feels that all of the most important design specifications were met, namely those pertaining to the size and weight of components as well as those specifications pertaining to the interface with the resident (buddy button).

12. Conclusion

Overall, this project can be called a success because most of the requirements given to us by the client, Seven Hills Pediatric Center in Groton, MA, have been met including the redesigns they requested. The client asked for a bowling game that would allow the residents to aim the bowling ball, provide audio feedback, and be lightweight and storable. While only three of the four requirements have been met, the one that was not met (audio feedback) was viewed by the project team as the least important of all the requirements. The components were brought to the Seven Hills and critiqued by staff members. Staff members generally approved of the design. They requested changes to two components, the launching ramp and the backstop. These components have been redesigned and rebuilt according to the client's wishes.

13. Recommendations

It is recommended that audio feedback be implemented in the Pin base. After audio feedback is implemented, it is recommended that all of the components be tested thoroughly by the staff at seven hills, and a new set of components be created from recommendations of the staff there. The tests at Seven Hills should especially focus on the portability of the system, since the overall weight of the bowling system has increased from the original weight of the Seven Hills bowling system. It is also recommended that the bottom edge of the launching ramp and pin base ramp have a curved transition to minimize momentum loss in the ball.

14. References

"Bounce 'n Splash." WHAM-O. 2008. WHAM-O, inc. 29 Nov. 2008 <<http://www.wham-o.com/default.cfm?page=viewproducts&productid=16&category=1>>.

Danielak et al, Ann C. Toy bowling game. Marvin Glass & Associates, assignee. Patent 4832339. 1989.

"Electronic Bowlercade." Amazon.com. Amazon.com. 17 Nov. 2008 <<http://www.amazon.com/moose-mountain-electronic-bowlercade/dp/b00008v5x9>>.

"GanttProject 2.0.8." Gantt Project. 09 Nov. 2008. Gantt Project Team. 13 Dec. 2008 <<http://www.ganttproject.biz/>>.

Lichodcinejewski, Michael, Seum L. Gan, Craig D. Sellers, John Wildman, Scott S. Clark, and Karl R. Meyer. Toy Bowling Game. Hasbro inc., assignee. Patent 6283872. 2001.

Lorber, Kenneth. Bowling Ball Return Mechanism. Patent 3831939. 1974.

Ross-Sullivan, Mark. Collapsible Ramp for Projecting Bowling Balls. Patent 5314384. 1994.

Seagrist, Ryan. "History of Bowling." ESSORTMENT. 2002. Page Wise.inc. 10 Dec. 2008 <http://www.essortment.com/all/historyofbowli_rkdx.htm>.

"Seven Hills Foundation: About Us". Seven Hills Foundation. 2006. 02 Dec. 2008. <<http://www.sevenhills.org/about.html>>.

"Silly Six Pins Game." Hasbro. 2008. Hasbro. 03 Dec. 2008 <http://www.hasbro.com/shop/details.cfm?guid=8ec024fc-6d40-1014-8bf0-9efbf894f9d4&product_id=8620&src=endeca>.

Simpkins, R. F. Ball Game Device. Patent 5431398. 1995.

15. Appendices

Appendix A: MathCAD Calculations

Ramp Ball Velocity Calculations

Jonathan Welch

Theoretical Velocities For Ball Assuming Frictionless Surfaces, and Perfectly Circular Ball, but neglecting the energy lost due to rotational inertia

Variables

Weight	Gravity	Mass	Velocity	Height
$W := 5\text{lb}$	$g = 32.1 \cdot \frac{\text{ft}}{\text{s}^2}$	$M := \frac{W}{g}$	V	$h := 31.7 \text{ in}$

Governing Equation

$$M \times g \times h = (1/2) M \times V^2$$

Theoretical Velocity

$$V := (2 \cdot g \cdot h)^{\frac{1}{2}} = 13.0 \cdot \frac{\text{ft}}{\text{s}}$$

Using actual Ramp with height at bottom of the ball = 31.75 in

distance
 $d := 15\text{-ft}$

Times

$t_1 := 1.48\text{-s}$	$t_2 := 1.46\text{-s}$	$t_3 := 1.45\text{-s}$
$t_4 := 1.40\text{-s}$	$t_5 := 1.45\text{-s}$	$t_6 := 1.46\text{-s}$

$$t_{\text{avg}} := \frac{(t_1 + t_2 + t_3 + t_4 + t_5 + t_6)}{6} = 1.45 \text{ s}$$

Average Velocity = d/t

$$V_{\text{avg}} := \frac{d}{t_{\text{avg}}} = 10.3 \cdot \frac{\text{ft}}{\text{s}}$$

The variation from theoretical to actual is due to two main factors. The intentionally neglected angular acceleration of the ball, and the friction from the ramp.

Appendix B: Budget Summary

Electronics

Ball Release (not reimbursed)

Solenoid.....	\$13.95
Miscellaneous electrical component.....	28.00

Building Materials

PVC Tubing	\$26.25
Wood	\$85.94
Steel	\$71.03
Screws/Fasteners.....	\$41.52
Hardware	\$110.09
Tools	57.04

Total Reimbursed **\$391.87**

Grand Total..... **433.82**

Appendix C: Engineering Drawings

Pin Base

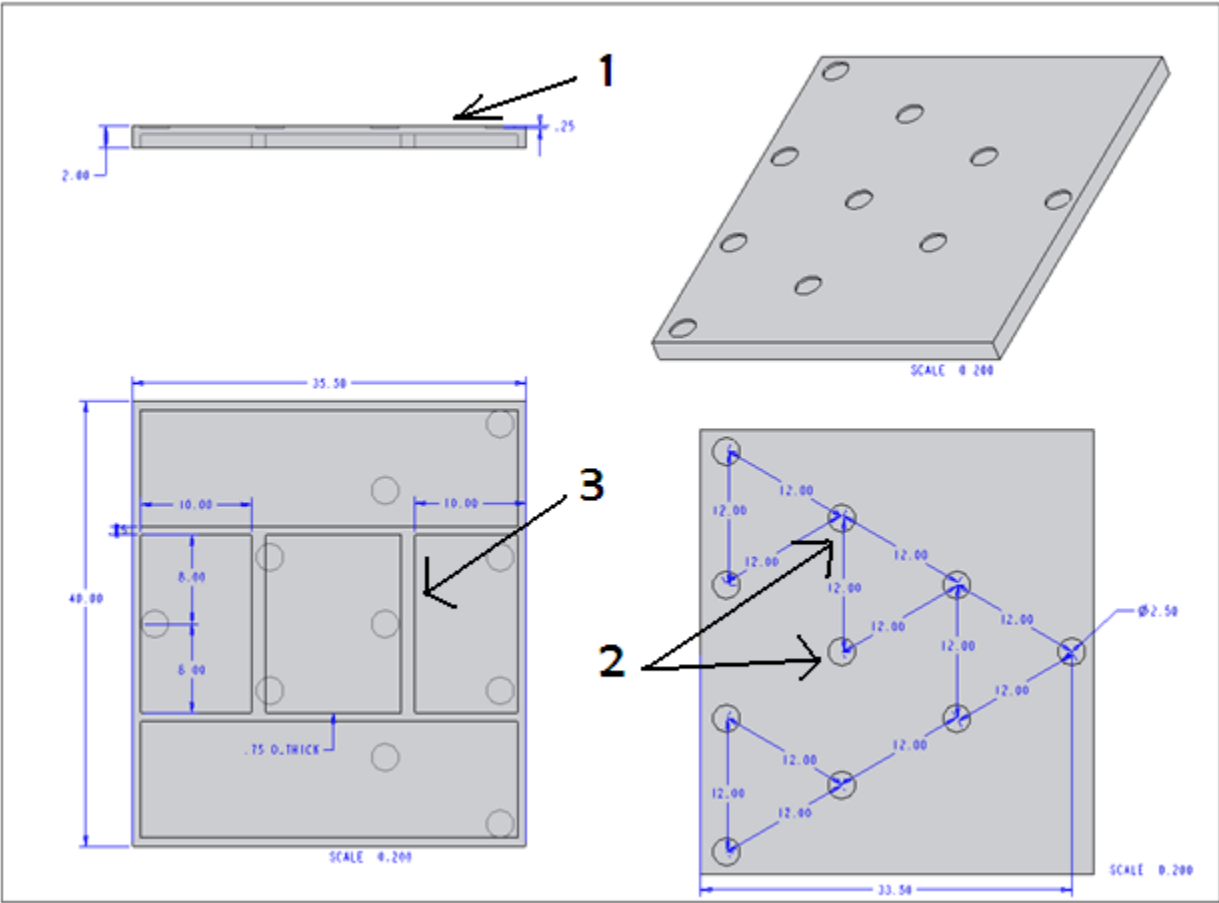

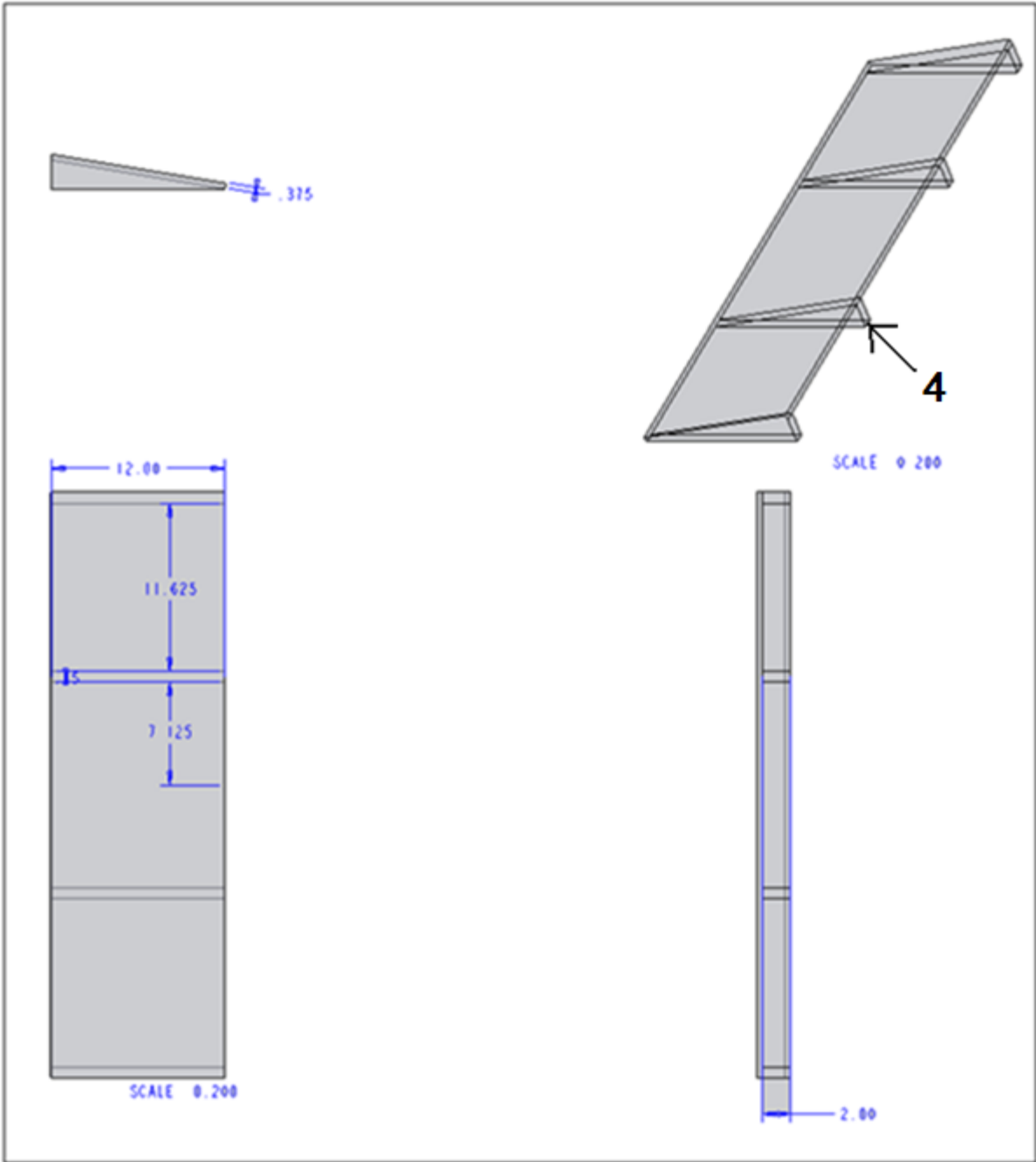

Ball Return

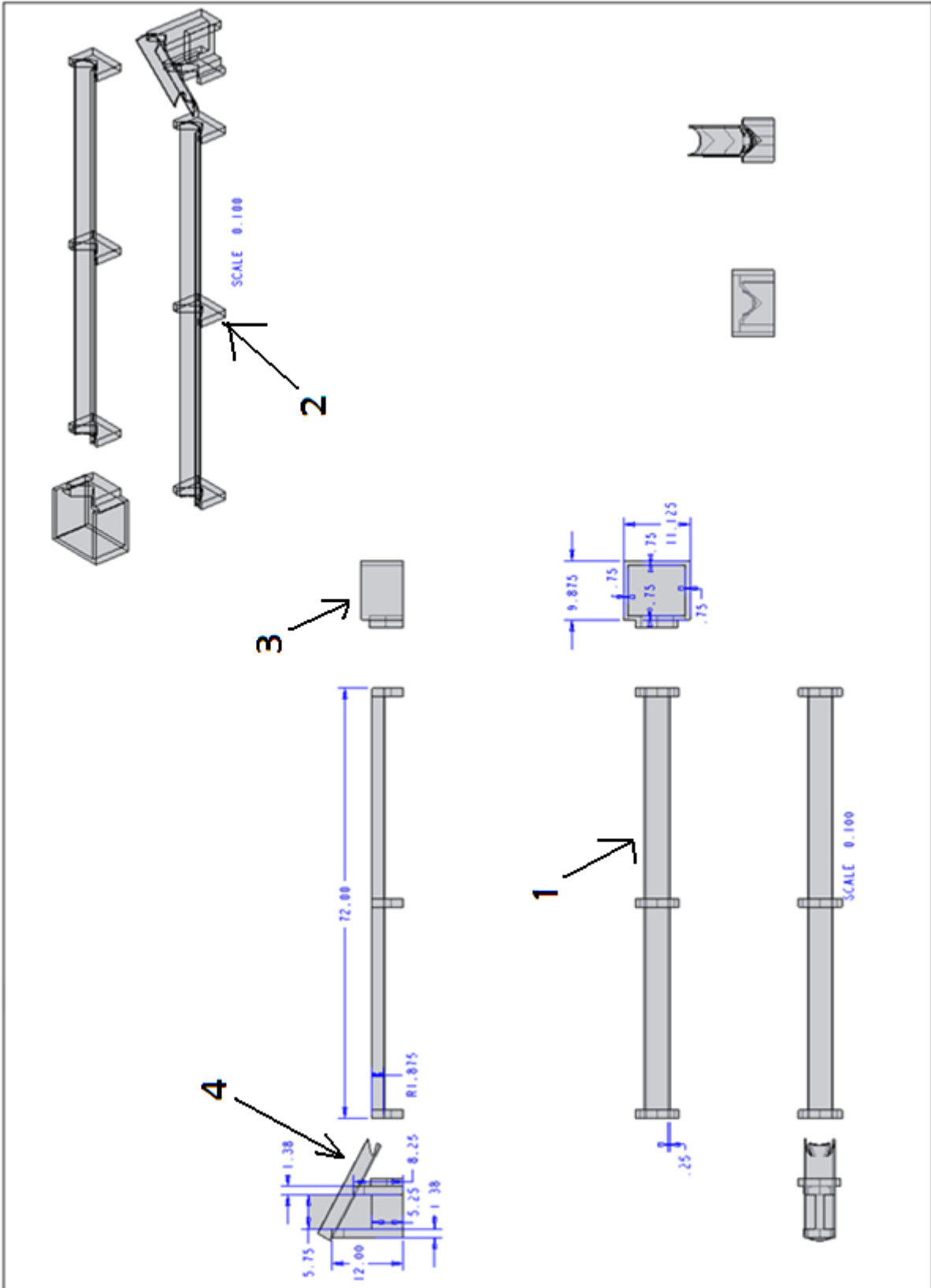

Ball Catcher

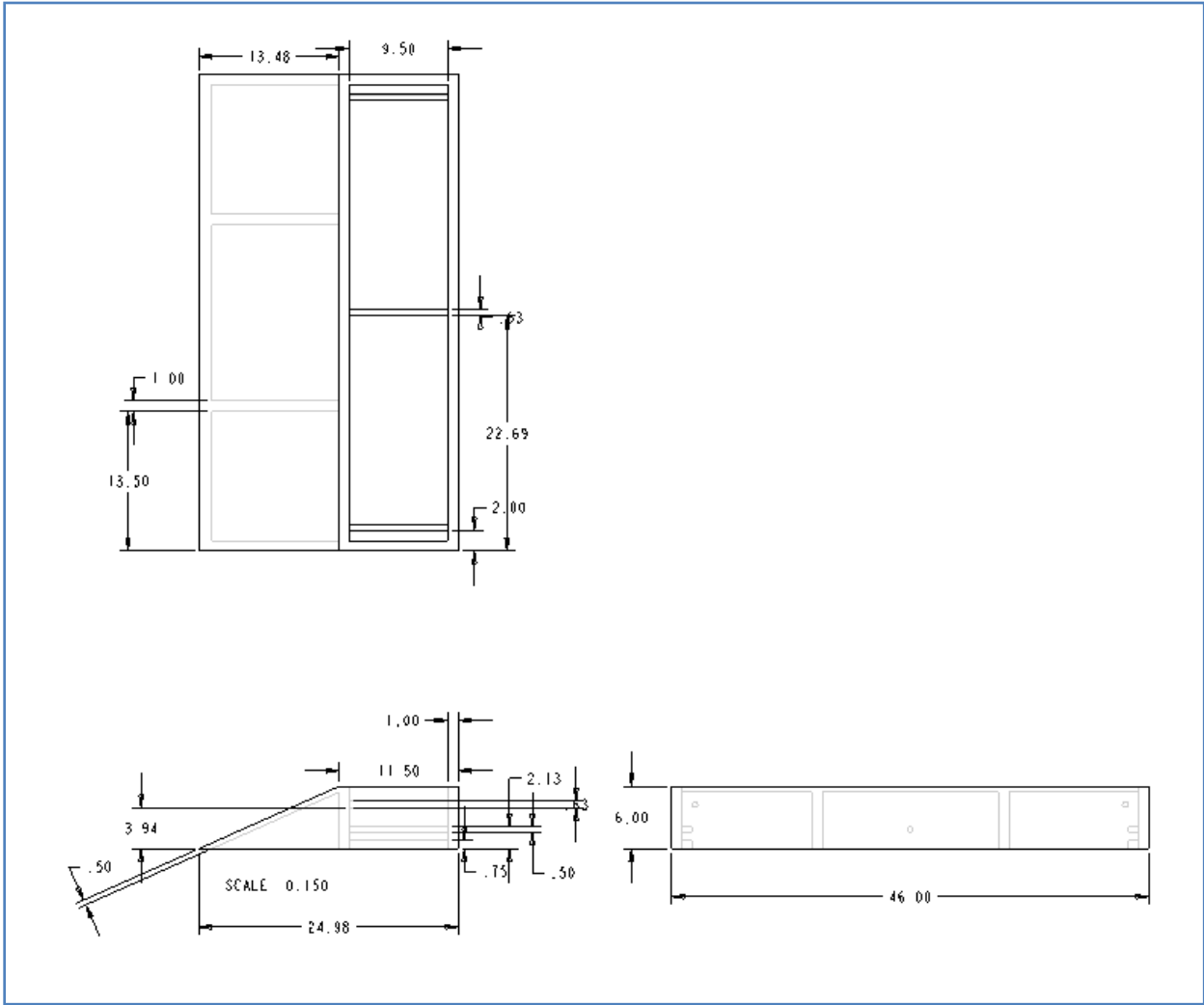

Incline panel for the Ball Catcher

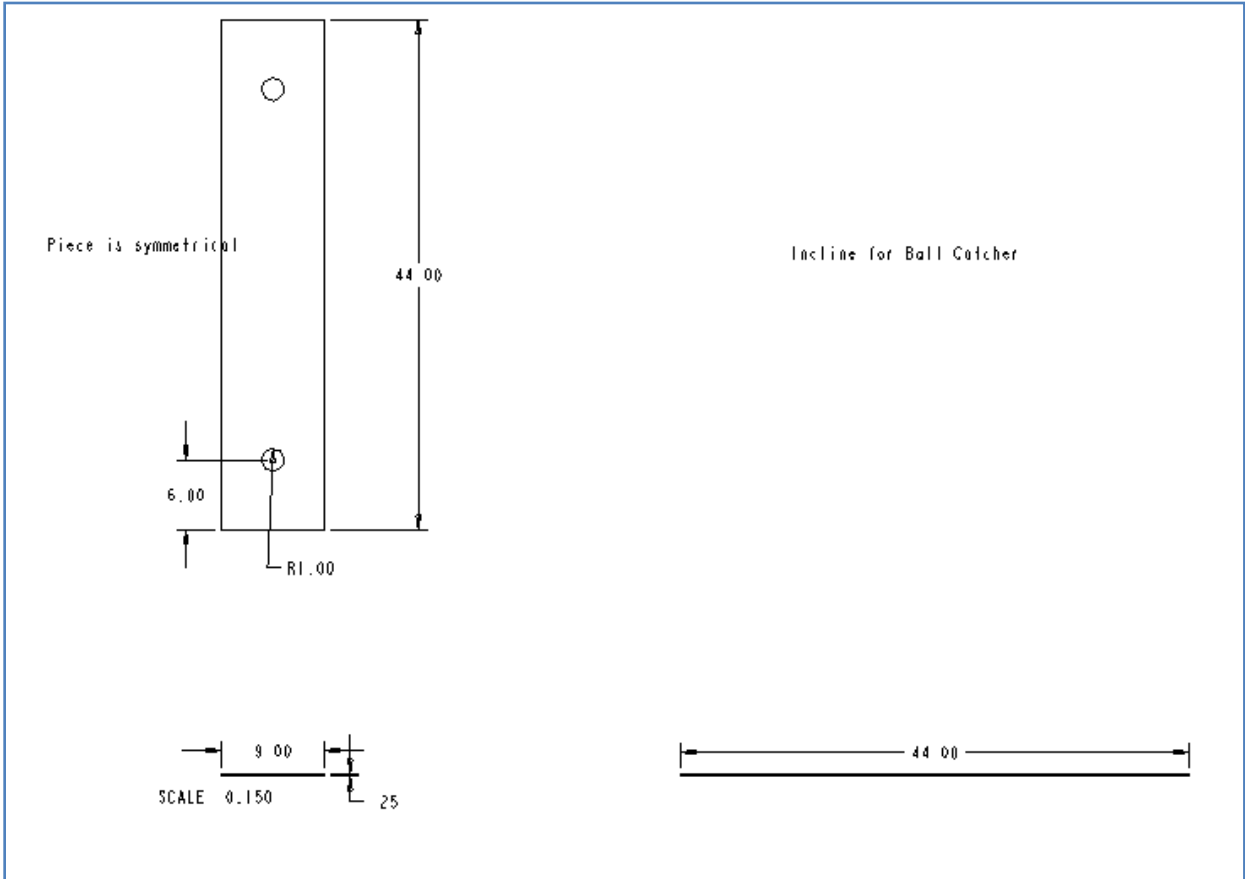

Backstop Panels

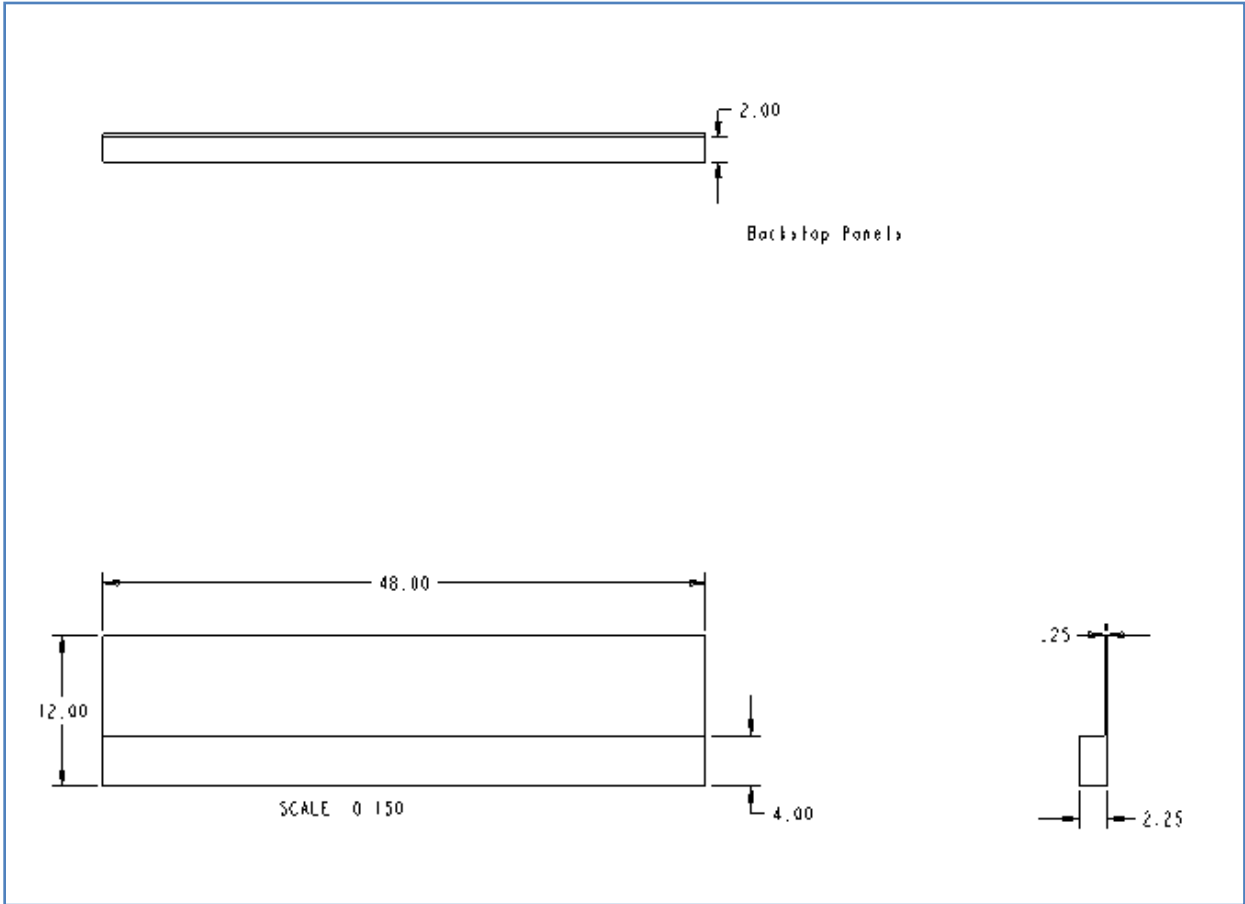

Note1: There are three panels which make up the backstop, but all three share identical dimensions.

Note2: The supports are attached at the midpoint of the length of each side panel and 15 inches from either end on the middle panel.

Backstop Panel Supports

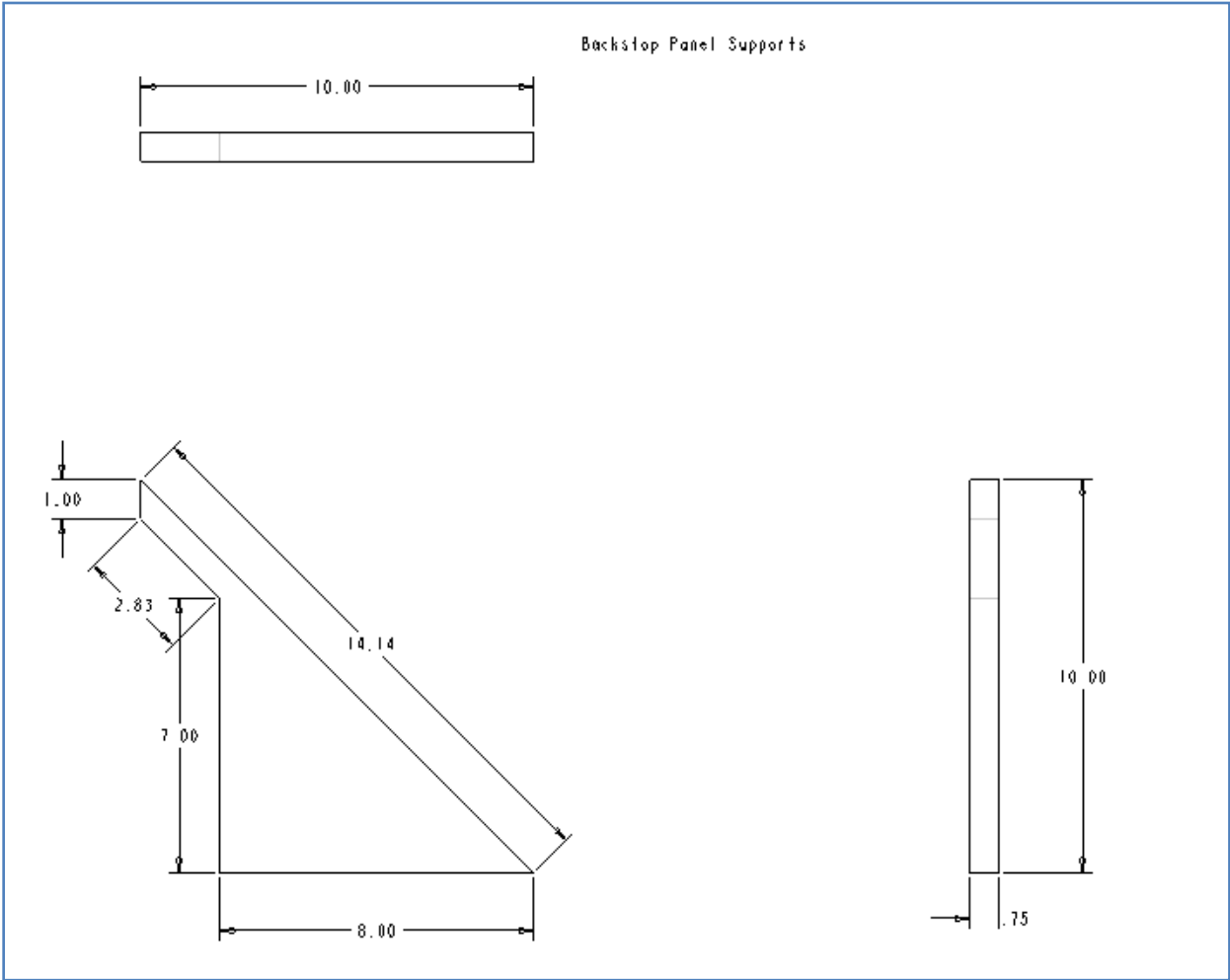

Launching Ramp

