

Telescoping Snowboard Pole

A Major Qualifying Project Report:

Project # JMS 09 01, JMS 09 02

Submitted to the Faculty

of the

WORCESTER POLYTECHNIC INSTITUTE

in partial fulfillment of the requirements for the

Degree of Bachelor of Science

By

David Parry

Michael Case

Alex Goudas

Date: April 30, 2009

Table of Contents

Table of Contents	2
Table of Figures	4
Acknowledgments.....	6
Executive Summary.....	7
Abstract.....	8
Introduction	9
Background	11
Target Population:	12
Materials Selection:	12
Current Locking Mechanism Patents:	14
Why Our Design is More Suitable For a Snowboarder:	20
Areas of Investigation	22
Functional Requirements:.....	22
Design Constraints:	22
Design Considerations	23
Concept 1: Spring Loaded Extension Pole.....	23
Concept 2: Manual Extension with Automatic Locking System.....	24
Concept 3: Manual Extension with Internal Automatic Locking System	24
Concept 4: Rotating, 360° Internal Locking System.....	25
Concept 5: Twisting coil-pin locking system	25
Concept 6: Toothed center column with coil mechanism	26
Concept 7: Crank Slider Arms & Locking System	29
Concept 8: Crank & Slide with Hex bolt Center Column.....	31
Concept 9: Hex bolt Crank & slide with washers/stoppers.....	33
Concept 10: Addition of hex nuts and springs incorporated	35
Concept 11: Bottom Segment.....	36
Final Design.....	37
Preliminary Design Description:.....	38
Making a Solid Model:	39
Bushing:.....	42
Spinners:	45

Extension Arms:	46
Bottom Locking Mechanism Design:.....	47
Adjustable Handle Design:	49
Pole Storage:	51
Stress Analysis:.....	51
Critical Load:.....	51
Bending Strength with Fixed Point:	53
Extent of Compression on the Polycarbonate Caps and Rings:	54
Parts Machining and Construction.....	56
Description of Cutting and Drilling the Parts Needed:.....	57
Machining of Small Parts:	58
Bushing Assembly:	58
Bottom Locking/Release Mechanism:	60
Pole Assembly	62
Handle and Handle Bushing:.....	62
Testing:.....	63
Refining:	64
Conclusions	65
References	67
Appendices.....	67

Table of Figures

Figure 1 – Material Properties of Various Metals.....	13
Figure 2 – Physical Properties of Various Materials	14
Figure 3 - U.S. Patent No. 4,424,987.....	16
Figure 4 - U.S. Patent No. 6,938,927.....	18
Figure 5 - U.S. Patent No. 5,387,048.....	20
Figure 6 – Coil-pin Locking Design	26
Figure 7 – Toothed Center Column Design.....	27
Figure 8 – Full Pole View of Toothed Center Column Design	28
Figure 9 – Side View of Crank Slider Locking Mechanism.....	30
Figure 10 – Top View of Crank Slider Locking Mechanism	30
Figure 11 – Preliminary Hex Bolt Center Column Design.....	32
Figure 12 – Top View of Preliminary Hex Bolt Center Column Design	32
Figure 13 – Multiple Views of Crank-Slider with Washers and Stops Design	34
Figure 14 – Hex Nut and Spring Additions Side View	35
Figure 15 – Bottom Segment with Basket Release	37
Figure 16 – Final Design Sketch of Locking Mechanism	38
Figure 17 – Exterior View of Locking Mechanism.....	41
Figure 18 – Section View of Locking Mechanism.....	41
Figure 19 – Isometric View of Bushing.....	43
Figure 20 – Bushing View Highlighting Countersunk Bottom Hole.....	44
Figure 21 – Bushing Cross Section	45
Figure 22 – Spinner Solid Model	46
Figure 23 – Extension Arms Solid Model	47
Figure 24 – Bottom Locking/Releasing Mechanism.....	48

Figure 25 - Handle Adjustment Design Extended	50
Figure 26 - Handle Adjustment Design Collapsed.....	50
Figure 27 – Prototype Bushing Assembly	59
Figure 28 – Basket Section Extended (Arms Retracted)	61
Figure 29 - Basket Section at Rest (Arms Extended).....	61
Figure 30 – Fully Assembled Prototype (Extended).....	63
Figure 31 – Fully Assembled Prototype (Collapsed)	63

Acknowledgments

We would like to thank Professor John M. Sullivan Jr. for his support, patience and guidance in completing this project. We would also like to thank Professor Mark W. Richman for his assistance in working out some of the technical equations. A special thank you is extended to Neil R. Whitehouse for teaching and guiding us through the long and tedious machining process, this project would not have been possible without his help.

Executive Summary

Seeing a need for telescoping ski poles for snowboarders we designed a pole different than any other previously created telescoping pole to cater to the needs of a snowboarder. The pole can be safely stored on the board without interfering with the boarder during riding. The pole extends to its locked position and is easily collapsible with winter gloves on. All locking and unlocking mechanisms are located within the poles themselves with no exterior holes. This ensures no debris enters the pole, which can cause complications. The pole also features an adjustable handle which can cater a range of riders with a single pole, and also extends the lifetime use of the pole. It can be used anytime by the rider whether to traverse across a flat or even propel them up a small incline. Many features of this novel pole design have not been successfully implemented in any previous telescoping ski pole.

Abstract

A telescoping support pole was developed as a new snowboarding accessory. This novel device utilizes completely internal locking and releasing mechanisms to avoid the introduction of foreign elements such as dirt and water to the system. Each pole segment is free to rotate, preventing torque damage on the assembly. The pole addresses multiple problems that snowboarders may encounter such as free standing support and assistance with traversing across flat or inclined areas. It can be collapsed and extended without removal of winter gloves. This accessory can be safely and easily stored on the person and features an adjustable handle to cater to a wider range of riders.

Introduction

The goal of our MQP was to design and develop a telescoping snowboard pole to assist snowboarders. The pole can be used to help balance the rider while standing, as well as propel themselves along a flat plane or moderate slope. It is quite common for a snowboarder to come to a flat or uphill gradient where they are required to detach one of their bindings in order to propel themselves forward with their free foot. Detaching a binding can be an annoyance since it takes time, and often results in snow getting stuck to the bottom of the boot. It is also somewhat difficult to propel them forward using one foot. Another cause for concern is when a snowboarder is stationary and is standing on their board. It is much more difficult to remain standing on a snowboard than it is on skis, and the snowboarder may need to sit down on the snow to remain stationary. By using a ski pole, a snowboarder would be able to remain stationary while standing, and be able to propel themselves along a flat or slight slope. It is inconvenient and possibly dangerous for a snowboarder to carry a standard ski pole while descending a mountain. However, by making a ski pole collapsible to a smaller size, a snowboarder can safely store a pole on the inside of their lower leg, and use it when they need it. Our project was to develop a pole that can solve these typical problems snowboarders face, without having to carry a standard full length pole.

Telescoping poles are frequently used in various applications such as hiking, umbrellas and ladders. However, their designs would not be able to meet our functional requirements. These pole designs would not be able to withstand the forces applied to it, the environment conditions it would be exposed to, or be able to collapse to our desired length. Our design is such that the pole is able to be collapsed enough for the rider to safely store it on their person. It

also needed to make the pole as resistant to winter weather conditions as possible. Since the pole would be exposed to a cold and wet environment, it was decided to develop a pole with as little external mechanisms as possible. The pole would need to be able to sustain varying loads during different types of use as well. Different body sizes and weights were taken into account to decide on a target population. We realized that we would need to design a pole as similar to a normal ski pole possible to provide proper assistance to snowboarders. This meant it would have to be as similar in size, weight, durability, and functionality. The pole would have same capabilities as a standard ski pole, but would enable the snowboarder to safely store the pole when they aren't using it. There are other telescoping poles available for other activities, but none of them are able to collapse far enough to be stored while riding, or to meet our other functional requirements. Since there is no product current available to deal with the problems snowboarders face, our project was developed in order to solve some of these issues.

Background

Currently in the snowboarding market there are no devices to aid riders in the instances where they encounter flat or inclined slopes down trails. When this does happen the riders are forced to a couple of inconvenient solutions. One of these is bending down and awkwardly propelling themselves along with their hands in order to pick up some momentum. Another is a technique developed where one balances and waddles on each edge of the board to gain ground or momentum, but this is more of a skill and not everyone especially older riders can do this. The third and most inconvenient is actually taking one foot out of the bindings and push yourselves to an area where you can sit down and reattach your foot to the binding and still be able to get up and continue down the trail. These scenarios are not only inconvenient, but can be dangerous as well. Being stuck in a middle of a trail can leave one like a sitting duck for another rider to come along and run into. You want to get up and out of the path of anyone as fast as possible and continue along your trail. These factors have lead us to realize a need for a telescoping pole to assist one in times of need such as these.

There are telescoping ski poles available on the market today for skiers, but they are not suitable for a snowboarder. One major issue the poles have today is that they don't collapse that small, or at least small enough to be safely stored on the board or person. In fact most poles can only collapse to half their size. Another issue with the current poles on the market, whether they are trekking or ski poles, is their locking mechanisms. Most feature external locking mechanisms and are difficult to activate during riding. If one was to increase the pole segments to condense the poles the locking mechanisms would just make it even more difficult to close. The external locking also can allow for debris to enter and jam up the mechanism. These issues

with the poles on the market today is what led us to decide to design a new pole that could overcome these problem and then some.

Target Population:

We wanted to target a height population that would be within 80% of the average American male and female riders in the snowboarding market today. Making educated conclusions off of previous works we decided to aim for a range between 5'5" and 5'10". The adjustable height feature of our pole could make up for our margin of error on our target population.

Our target population for age is wide being teenagers to middle age adults (13-40). Making the pole visually appealing and with extra bells and whistles can attract a younger population that would use this device as a convenience option. Older riders can see this pole as more of a necessity due to their physical condition. This pole can aid the older target population where flat and inclined slopes can be more taxing on the body.

Materials Selection:

The materials for the prototype and final product design vary quite a bit. For the prototype pole it was decided to use aluminum because it is a lightweight metal compared to most, easily machinable in most cases, and cost effective for a prototype. The best material to use for the final telescoping pole would be carbon fiber epoxy. Carbon fiber epoxy is composed of very small carbon atoms which are aligned in a way that give it great strength especially in stiffness. Not only is it strong, but lightweight too, and has a low tensile modulus. Carbon fiber

epoxy is perfect for the pole because it has a very low coefficient of thermal expansion and moisture doesn't affect it either. Along with freezing not being an issue with carbon fiber it is also one of the most non-corrosive materials. According to Figure 1 below, carbon fiber has a tensile strength about 10 times that of aluminum and 5 times larger than steel. According to this chart, carbon fiber also has a very low density and specific gravity meaning it's a very strong material but still very light.

MATERIAL	TENSILE MODULUS (MSI)	TENSILE STRENGTH (KSI)	SPECIFIC TENSILE MODULUS (MSI)	SPECIFIC TENSILE STRENGTH (KSI)	SPECIFIC GRAVITY	DENSITY (lbs./in.³)
CARBON FIBER	33	580	18.3	322	1.8	.065
CARBON EPOXY COMPOSITE	20.3	275	13.1	178	1.54	.056
6063-T6 ALUMINUM	10	36	3.7	13.3	2.71	.095
TITANIUM	15	170	3.25	36	4.62	.162
HIGH CARB. STEEL 1090	30	122	3.8	15.6	7.82	.274
ARAMID FIBER	18	400	12.5	278	1.44	.052

Figure 1 – Material Properties of Various Metals

For the inner bushings that hold the locking and unlocking components of the pole, polycarbonate plastic was selected. Polycarbonate is a lightweight plastic that, according to Figure 2 below, has a compressive strength of 12,000 psi and a tensile strength of 9,500 psi. These values prove that the material is hard enough to withstand the expected forces calculated in a later section, but still easily machinable. As one will later see, our bushing designs are so small that selecting a plastic that could be extremely thin yet still hold its strength properties was crucial.

Properties	Units	Test	Peek Unfilled	Ultem® 1000	Torlon® 4203	Torlon® 4301	VespeI® SP-1	Teflon® PTFE (Unfilled)	Derlin® AF PTFE-Filled	Nylon (Unfilled)	Poly-Carbonate
Density	lb./in. ³	D792	0.047	0.046	0.051	0.052	0.051	0.078	0.054	0.042	0.043
	g/cm ³		1.31	1.28	1.41	1.45	1.43	2.16	1.50	1.15	1.2
Water Absorption	%	D570	0.10	0.25	0.4	0.4	at 73°F 0.24 48hrs at 122°F 0.72	<0.01	0.2	0.3	0.12
Tensile Strength	psi	D638	16,000	16,500	18,000	12,000	at 73°F 12,500 at 500F° 6,000	3,900	8,000	11,500	9,500
Tensile Modules	psi	D638	500,000	475,000	600,000	800,000	-	80,000	435,000	425,000	320,000
Tensile Elongation at Break	%	D638	20	80	10	3	at 73°F 7.5 at 500F° 6.0	300	15	50	60
Flexural Strength	psi	D790	25,000	20,000	24,000	23,000	at 73°F 16,000 at 500F° 9,000	No Break	12,000	15,000	15,000
Flexural Modulus	psi (Kpsi)	D790	600,000	500,000	600,000	800,000	at 73°F 450,000 at 500F° 250,000	72,000	435,000	450,000	375,000
Compressive Strength	psi	D695	20,000	22,000	24,000	22,000	10% strain at 73°F 19,300	3,500	16,000	12,500	12,000
Compressive Modulus	psi	D695	500,000	480,000	700,000	950,000	350,000	70,000	350,000	420,000	240,000

Figure 2 – Physical Properties of Various Materials

Inside of these bushings, containing the moving parts for locking and unlocking to occur, we chose to use aluminum. One will later see that these are the small parts we needed to machine. These parts include the spinners and the arms, two crucial elements in our bushing design. Other parts inside are to be bought straight from a distributor and implemented into the system instead of manufacturing them for cost and ease.

Current Locking Mechanism Patents:

During the first stages of research, a few patents were found that later helped us formulate our initial design features. After working through many design iterations we came up

with the final novel design, but there are a few patents worth referencing due to their influence on our thinking about the pole.

One of the first patents researched with an internal locking and unlocking mechanism was U.S. Patent No. 4,424,987, January 10th, 1984. This patent helped us formulate the idea that we would need to construct a bushing element that would be the housing for the locking and unlocking mechanism. It would also be the site for where the pole would meet with the other pole collapsing and initiate the locking and unlocking sequence. This patent also showed us that there is an issue with a pole that does not have tracks or groves to control the pole orientation where two poles would interact with the bushing. This was important to formulate the plan to create a pole system that was fully rotational at all points making the locking mechanisms be able to work in any orientation.

The design used in this patent uses an interesting spring-loaded pin that slides along an internal tract in their bushing until it reaches a locking position. To increase the chance of this interaction between pin and the track in the bushing they used two pins and two tracks. This allows one to attempt to lock in at least 180° rather than 360°. Below, Figure 3 shows the internal bushing and spring loaded pins, the design of the track, the pole itself, and another side view of the bushings.

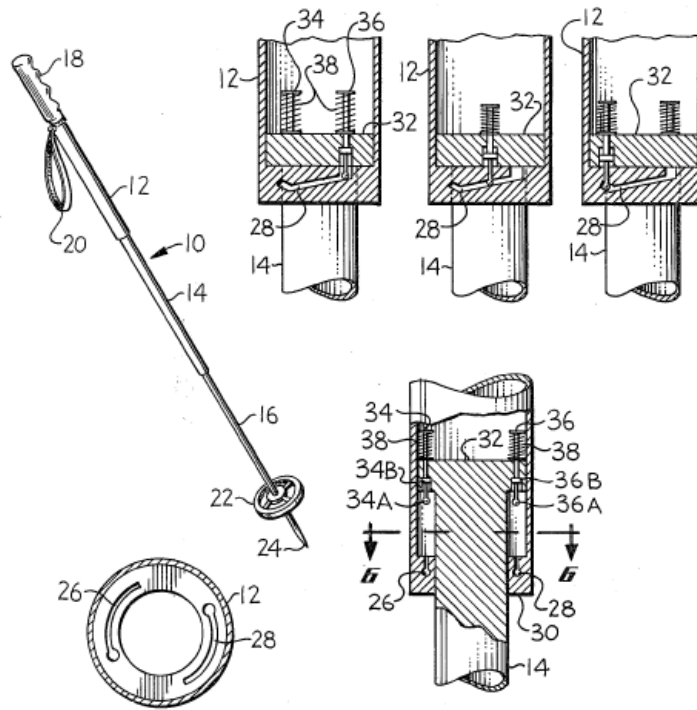

Figure 3 - U.S. Patent No. 4,424,987

Although this design gave us a good start on where to begin it also raised a number of issues we would have to address and overcome. The design in this patent does not affectively address multiple pole segments. This was a major issue to us because in order to create the smallest collapsing pole we would need to create multiple small segments to condense into one another. This design was just too simplistic for our needs to be able to take away much from the mechanisms within the bushings and give us any clue in what direction to go from there.

One of the most significant patents we looked at that gave us a great idea of how we would have to go about creating this pole was U.S. Patent No. 6,938,927, September 6th, 2005. This patent is significant because it has 5 segments collapsing into one of the more reasonable sizes we've seen. All but one of its components is an internal locking and unlocking mechanism, which adds to its appeal. The design also sparked our ideas of using arms that could be used to

protrude through holes within the pole and act as locking mechanism. It also shows the best way to start and continue a sequence of unlocking once the pole has been extended to full length.

This patent uses a leaf spring pin that at its extended position is lodged through the hole of pole that it is fixed in, to the pole it's collapsed into. In this position the pole is locked as the pin acts as an effective wedging device between the two poles not allowing them to collapse. The first segment to start the collapsing sequence is the bottom one where a manual squeeze collapses the inner pin of the pole to collapse just enough to eliminate any blocking which would otherwise stop the two poles from sliding over one another. The top of the bottom pole is equip with a top cap which has an extended male protrusion, which when collapsed makes contact with the first spring leaf pin mechanism connected to a pinned lever. When the contact is made and pressure is applied the lever retracts the pin from the hole from which it locks the pole it sits within. This initiates the same following sequences with the other segments. Figure 4 below shows multiple pictures of the pole both collapsed and expanded, the bottom exterior manual release mechanism, and numbered from one to six, the events that occur to collapse the pole.

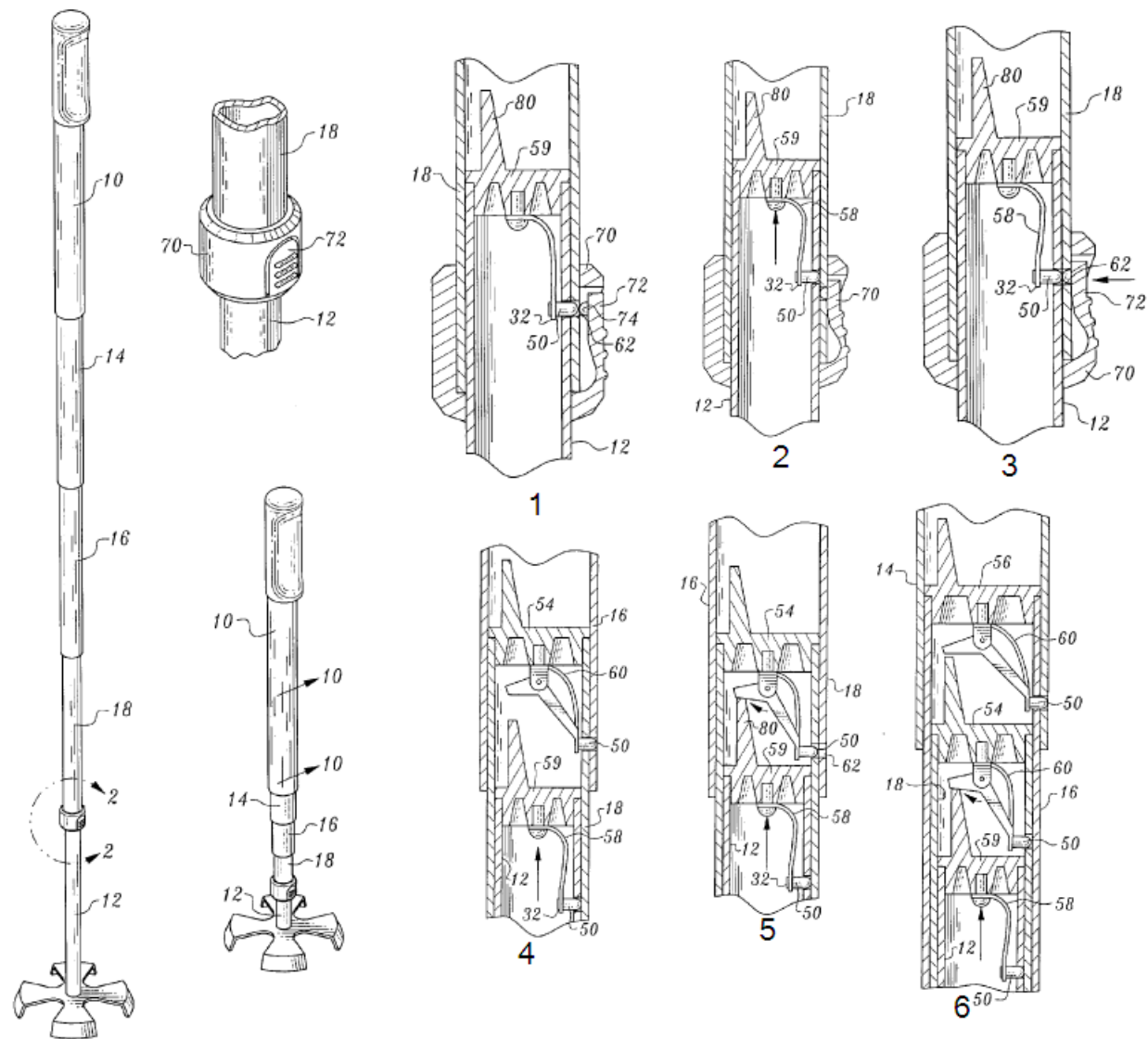

Figure 4 - U.S. Patent No. 6,938,927

Although this pole provided much hope and inspiration for designing our telescoping design it raised a number of issues that we had wanted to avoid. One main issue with this design is that the pole uses a pin system in such a way the when extended out the pole must line up with an exterior hole. Similarly the unlocking mechanism must contact a specific area within the next pole to create the desired collapsing affect. This means the poles must be grooved or tracked in some way in order to ensure the alignment of those components. Otherwise, the ease offered by this design is taken away. There is also one external locking and unlocking mechanism that is

located at the very smallest pole segment. This is an issue because we wanted to design a pole that would have no exterior mechanisms to assist in ease as well as debris control. Because this pole uses a pin design where the holes are located on the exterior poles there is no defense against foreign objects entering each individual segment of the pole, which can create problems when collapsing.

Another important patent referenced was one from an umbrella and it gave us some insight into how to go about designing an internal locking mechanism along with the patent above. U.S. Patent No. 5,387,048, February 7th, 1995 is a design for telescoping sticks of a multi-fold umbrella that uses a unique double pin system to create a desired locking or unlocked position. Using a U shaped stub which in its expanded position protrudes two pins through the walls of two rods, one being is housing and the other the one collapsing into it. The rods are almost a full circle, but with a notch on one side which allows for a cone shaped pin to protrude. The main feature we took away from this invention was the U shaped stub and its use of two pins to make a secure lock. Figure 5 shows an exploded and solid view of the umbrella locking system.

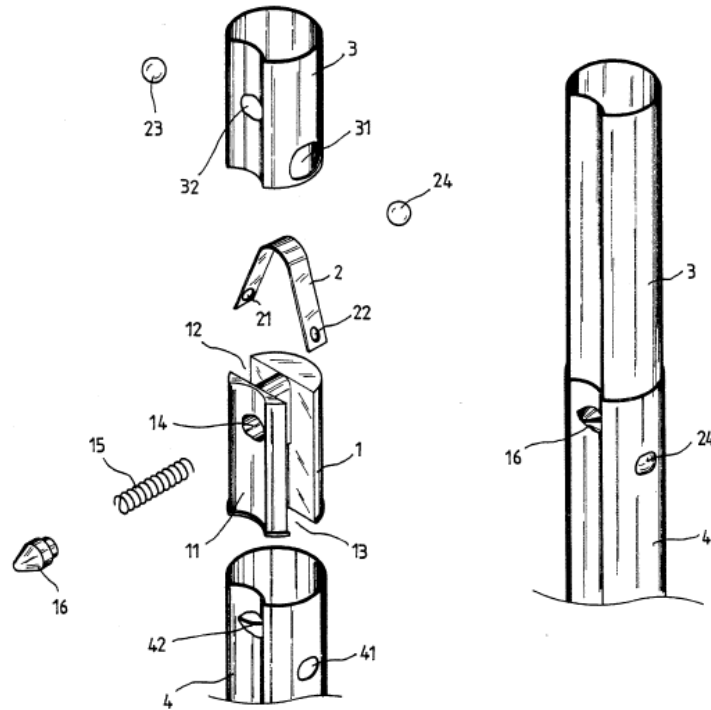

Figure 5 - U.S. Patent No. 5,387,048

Why Our Design is More Suitable For a Snowboarder:

Our design is optimal for snowboarders for many reasons. As seen in previous pole designs, they do not offer two point contact systems with 360° locking mechanisms, instead they use grooved tracks which eliminate structural strength. Although one of the patents above offers a unique internal locking mechanism, the pole is not entirely internal and includes one exterior releasing mechanism. Our pole is completely internal and has no exterior holes produced by pins that would allow debris inside. Since we addressed these issues, we were able to design a pole to collapse small enough that it can be easily and safely stored along the binding of the board, where due to axial movement of the human knee, will never interfere with the person while riding. Our pole also features an adjustable handle which has not been seen on telescoping poles before. This feature adds to the lifetime that a customer can own the product whether they grow or shrink in stature or buy new equipment. Traditional poles do not offer the same ease of use as

ours does or the ability to be collapsed so small and safely as to not interfere with the snowboarder. These features make this product most appealing to the snowboarding population.

Areas of Investigation

To develop a telescoping snowboard pole, there were many considerations to be taken into account. The pole needs to have similar qualities to a standard ski pole, while being able to collapse significantly, and be safely stored. As part of our preliminary design, we came up with specific functional requirements the pole would need to meet, and design constraints that would help us reach our design goals. The functional requirements were characteristics of the pole while being used as well as being stored. The design constraints deal with issues like safety, and developing a pole a wide range of snowboarders can use.

Functional Requirements:

1. Use while leaning to remain up right on flats or small slopes
2. Use to propel forward on flats or small slopes
3. Have a convenient way of retracting or expanding the pole.
4. Easily and securely able to lock while in use
5. Have a high durability to withstand weather and use.
6. Marketable & affordable to the snowboarding and skiing population
7. Secure and safe storage on binding of board or person
8. Easily obtainable while strapped into board
9. Must be able to withstand forces associated with average male & female

Design Constraints:

1. Safety-Factor
2. Storage must be able to withstand falls/contact with ground

3. Design must be within 2" height standard of 80% average male & female
4. Material Polycarbonate & Carbon Fiber Epoxy
5. Internal Locking mechanism/ Unlocking mechanism
6. Failure components easily accessible for replacement
7. Easy maintenance/cleaning
8. Reduce any external & internal degradation from dirt/ice/water
9. Minimum number of moving parts
10. Free rotating segments 360° to reduce stress

Design Considerations

Throughout the project we developed several different designs for a telescoping snowboard pole. We were able to change our designs to eliminate potential problems and finalize one specific design to meet our requirements. Here is a list and summary of different design concepts that we came up with as our project progressed. We also included pros and cons of each concept and why that design would not be successful.

Concept 1: Spring Loaded Extension Pole

This concept is based on the design of an umbrella. The pole would have a similar design to a basic umbrella with grooved tracks that would lock using the same external pin system in an umbrella. When the pins that held the pole fully contracted are released, the pole would automatically extend to full length and lock out when the pins reached the holes in the side of each section. The design would be convenient and relatively simple using an umbrella as a blueprint for our design. However, this design was not a good choice due to lack of strength as

well as the potential danger of having an automatic spring extension. With a spike on the pole end, and an extension length of about 50 inches, we realized that pole could be dangerous while riding or even used as a weapon.

Concept 2: Manual Extension with Automatic Locking System

This concept is similar to the first in still using designs from an umbrella. The pole would not have an automatic extension system, but would still have a grooved track and an automatic pin system. The pole would be manually extended along an internal grooved track until the pins reach the holes in the side of each section. We would have two pins for each part to increase strength in the locking system, as well as reduce stress on a single pin to lower the risk of failure. This design again would be relatively simple, and easy to use. The problem with this design is that the machining of an internal grooved track in each section would be extremely difficult. The holes in each section of the pole would also lead to more debris getting inside the pole, which could lead to ice buildup or other problems. They also could cause the strength of the pole to be altered since there would be two holes at each of the sections.

Concept 3: Manual Extension with Internal Automatic Locking System

This new concept eliminates the problem of a grooved track and holes in each pole. The internal locking system would prevent more water, dirt and ice from getting inside of the pole, and have greater strength than a pole with holes. The locking mechanism would consist of an internal bushing that could be would lock out with springs forcing pins on each side of the pole. The pins would be locked between the end cap of one pole, and an internal ring placed just above

the end cap. When the pole was unlocked, the lower poles would have a top bushing with a peg key on the top to push the pins in on the upper bushing. This design makes unlocking the pins very easy for the user with one motion. The downfall of this design is that to develop a bushing that could unlock with a peg key would be extremely difficult. The parts would need to line up exactly, and it wouldn't have a 360 degree locking system.

Concept 4: Rotating, 360° Internal Locking System

This design solves the problem of needing the internal parts to line up in order to unlock each part in each pole. The internal locking system would prevent more water, dirt and ice from getting inside of the pole, and have greater strength than a pole with exterior holes. The pole would not have an automatic extension system, but would still have a grooved track and an automatic pin system. The pole would be manually extended along an internal grooved track until the pins reach the holes in the side of each section. We would have two pins for each part to increase strength in the locking system, as well as reduce stress on a single pin to lower the risk of failure. This design again would be relatively simple, and easy to use. The problem with this design is that the machining of an internal grooved track in each section would be extremely difficult. The holes in each section of the pole would also lead to more debris getting inside the pole, which could lead to ice buildup or other problems. They also could cause the strength of the pole to be altered since there would be two holes at each of the sections.

Concept 5: Twisting coil-pin locking system

At this stage of design we decided to eliminate the original pin system that involves the collapsing of each pin back into its unlocking position by hand or by external/internal force.

Figure 6 below is a top view of the initial primitive coil-pin locking system that came to replace our previous design. Here we see a steel coil for flexibility that has two arms which retract and expand upon twisting the center component. One may note the shape of the housing to hold this component. The shape directs the arms where to slide during action. The advantage of this system is that it created a new force option for us to brainstorm around. It could also be easily made to fit into small pole segments, such as the ones we would be working with. The negative to be found are simply in its lack of detail, such as how to twist the mechanism and machine housing with such a unique and difficult shape. Many of these issues were addressed in the advanced concept following this one



Figure 6 – Coil-pin Locking Design

Concept 6: Toothed center column with coil mechanism

Shown in Figures 7 and 8, the toothed center column acts as a way of moving the coiled arms to lock and unlock. Twisting them into a gap created by a couple rings inside the pole creates an effective lock and stable locking mechanism. The toothed column extend through the bushing to active other bushings for unlocking motions. This design holds several flaws, one being the suspension of the center columns. If it sits on the plastic of the bushing friction is created and is a serious point for failure. There are also no guides to ensure where the arms will extend through the holes into the gaps for locking. The toothed columns are too long and don't allow the pole to collapse to its full potential. The also have no force extending it out to lock at

any moment, which can render the system useless if left in the unlock position when extending the pole. Although this design is set forward there are many problems in creating the bushings and moving parts found within it.

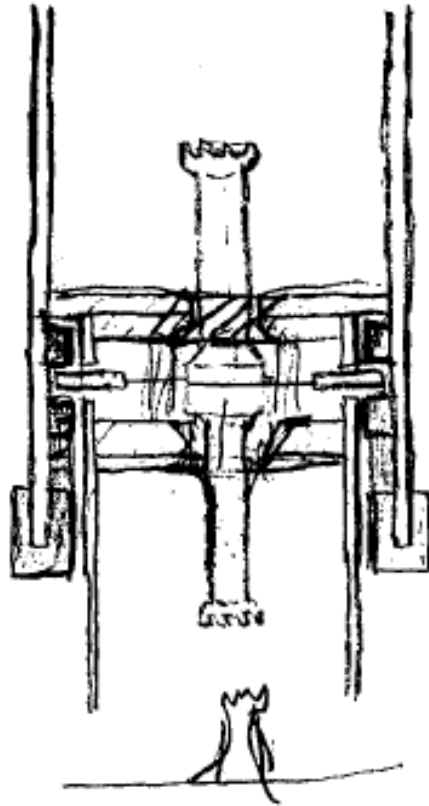

Figure 7 – Toothed Center Column Design

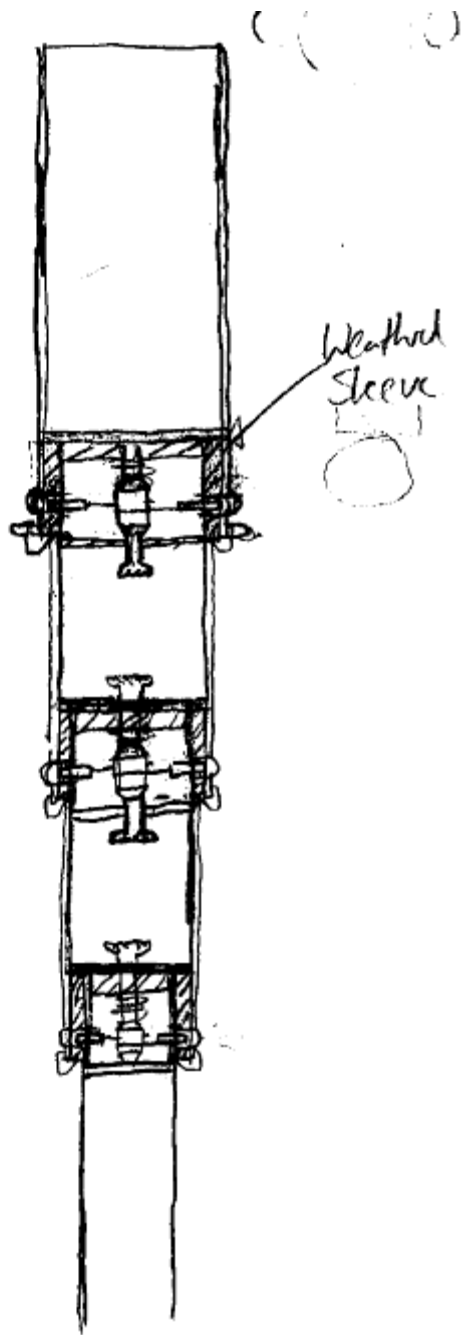

Figure 8 – Full Pole View of Toothed Center Column Design

Concept 7: Crank Slider Arms & Locking System

This design replaces the need for any sort of coil mechanism while still implementing the same function. This design also gives added benefits versus its predecessor. Using a crank and slide mechanism, shown in Figure 9, allows for a simpler bushing design. Although there were added moving parts the slide works perfectly horizontal in the center of the bushing. The slide's benefits range from its ability to collapse and lock within itself up a simple extension to and easy twisting motion to unlock the arms and collapse the pole itself. This primitive design uses a toothed center column to activate motion with a spring located in between itself and spinner arms which hold the arms itself. The toothed column exists on the top of the bushing to unlock the next section of pole. Four pins are used to hold the arms in place and allow them to swivel with ease. The design of the bushing had to be altered to create walls to stop over extension of the arms, shown in Figure 10, which could lead to mechanical failure in the inner workings of the mechanism. Flaws are found in this design as well, specifically in machinability. To create this bushing there would be complications in creating the walls and digging out the area for the moving parts. The bushing would have to be split in half then assembled and pinned inside of the pole. This would be difficult especially if one needed to take the bushing out to make simple repairs. Another noted flaw is making sure that the slide collapses in the right direction and doesn't bind on itself. Although this design creates new possibilities to explore in telescoping design, it still has its share of flaws to be dealt with.

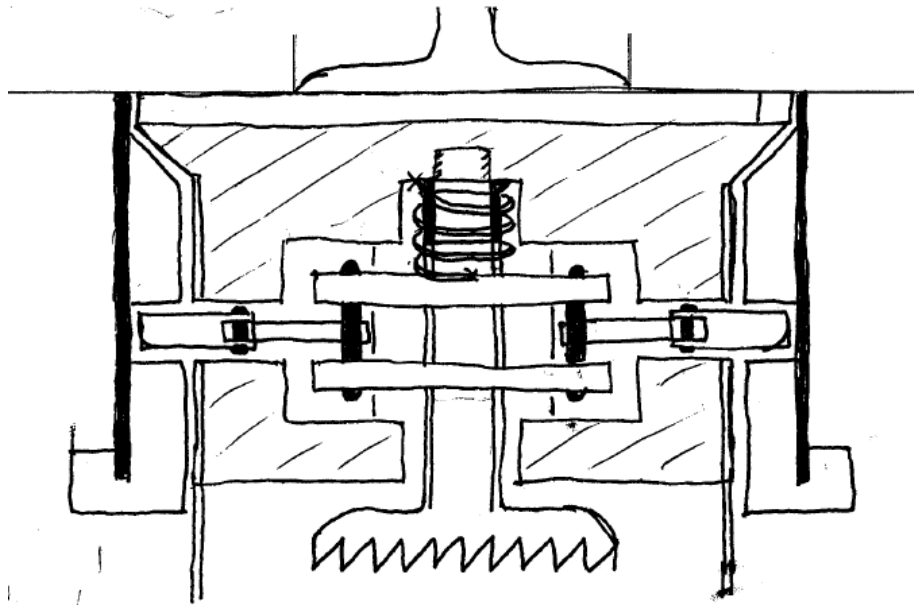

Figure 9 – Side View of Crank Slider Locking Mechanism

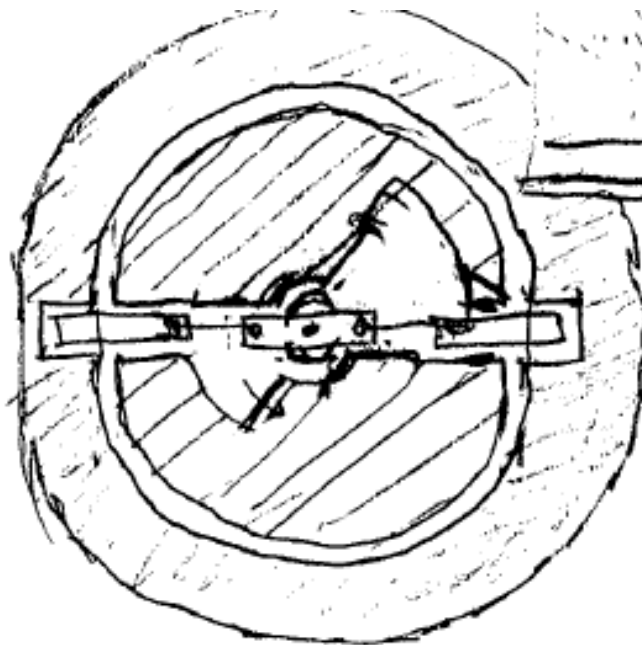

Figure 10 – Top View of Crank Slider Locking Mechanism

Concept 8: Crank & Slide with Hex bolt Center Column

This design replaces the toothed center column with a hex nut, along with a few other improvements. Using the hex bolt, shown in Figure 11, is an easy to find part which when matched with the male section acts exactly the same as the previous design. To solve issues of machinability we suspended the hex bolt by a washer that holds the body suspended and also reduces friction. A simple drill operation can be applied to round out the whole center of the bushing for the moving parts, shown in Figure 12. The spring was relocated to the bottom hole because the machinability issues previously addressed. To ensure that the spinners attached to arms stay suspended and don't grind along the bottom of the bushing a half shaft design was introduced and would be created by grinding down the hex bolt. Some flaws to be found in this design are found in the half shaft idea, spring relocation, and the newly suspended hex bolt and body. The half shaft might not twist properly if one side of it is shaved down. Also, the new placement of the spring would be difficult to attach and assemble. The body suspended may also prove to be difficult to attach to the hex bolt. The body of the bushing also doesn't contour the hex nut well enough to make it flush, which doesn't allow for the full collapsing potential.

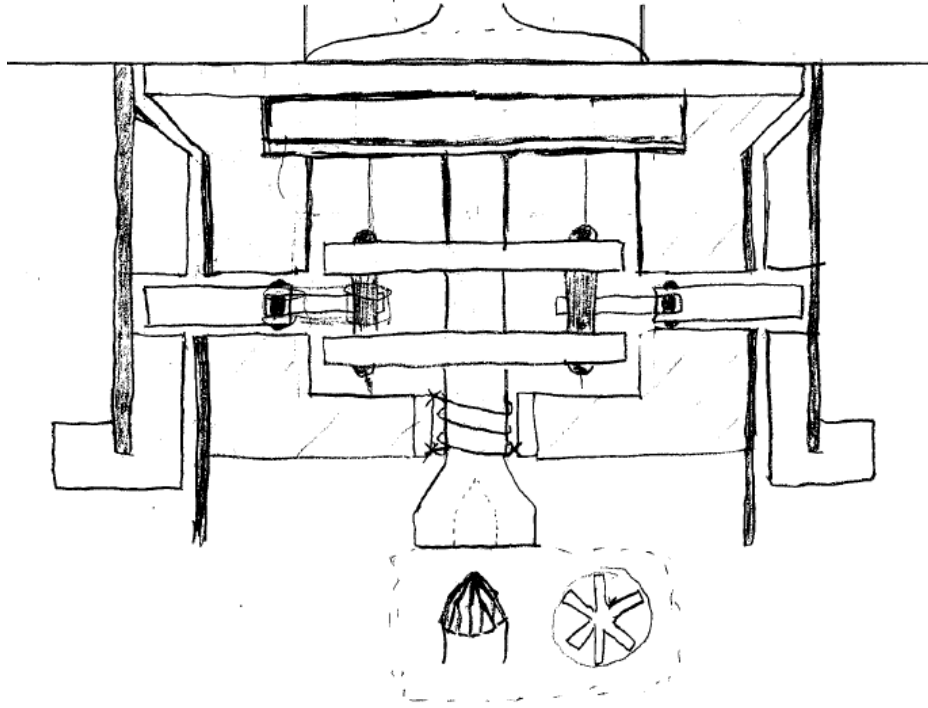

Figure 11 – Preliminary Hex Bolt Center Column Design

"Half Shot"

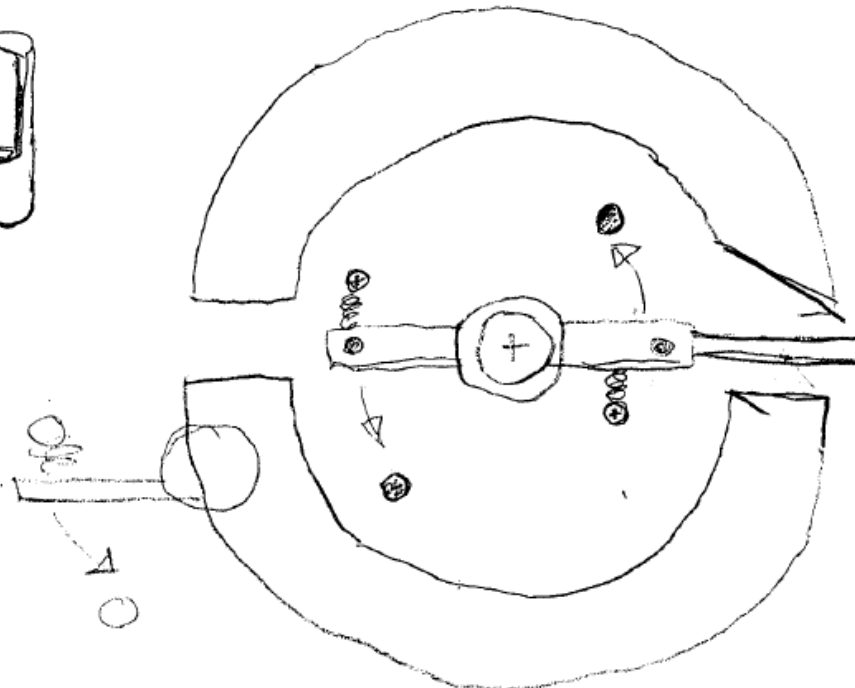

Figure 12 – Top View of Preliminary Hex Bolt Center Column Design

Concept 9: Hex bolt Crank & slide with washers/stoppers

This design reshapes the body of the bushing to be flush with the head of the hex bolt with a few other changes. The arms have now been considered and are pinned in an interlocking fashion. They have been offset on the spinner to ensure which direction they will move upon movement. A washer has been placed underneath the spinners as well to reduce any friction that might occur. Since the new bushing design doesn't have any walls to stop over extension of the arms pin have been dropped through the top washer into the bottom one creating a fixed stopping area. The spring has been moved to the top once again, but an alternative placement of the springs is also proposed. By attaching the springs to the new stopper pins from the washers and connecting them to the arms of the spinners an automatic extension to its original position is created. The springs are still an issue in this design and the top body that may prove to be difficult to create and assemble is still in the design. The arms are also extremely small and may prove to be difficult to machine. Multiple views of this design can be seen below in Figure 13.

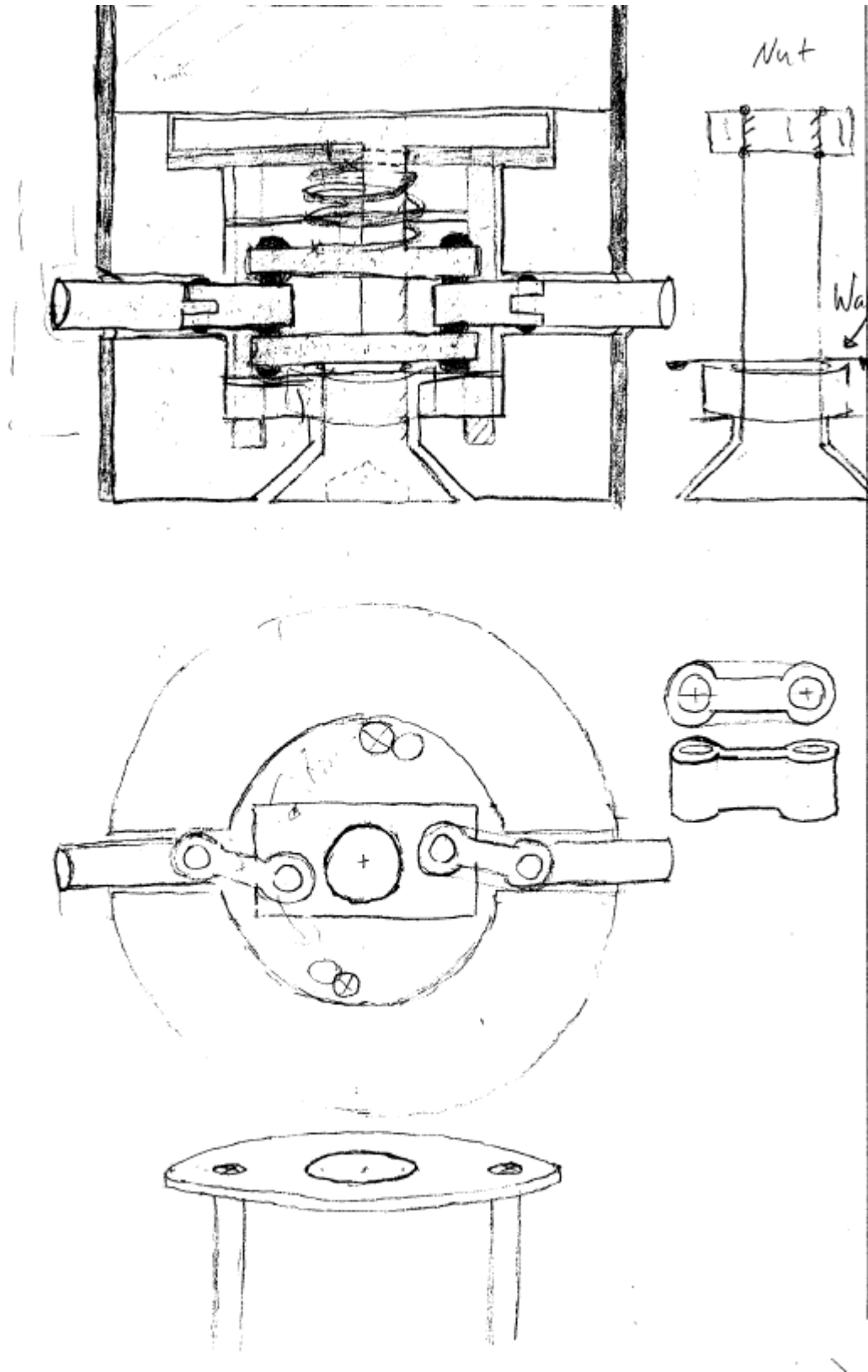

Figure 13 – Multiple Views of Crank-Slider with Washers and Stops Design

Concept 10: Addition of hex nuts and springs incorporated

This last design incorporates a little bit of every concept, but in an upgraded form. From concept 9 it only varies slightly. Instead of a body to hold the hex nut, we have two nuts twisted on and locking together on above the top washer. This suspends the body and uses practical parts which make assembly easier. The spinner shape has been altered to fit in the bushing space and provide proper movement of the arms. The springs have been set on the sides of the bushing and will go through a hole on each side to attach to the spinners. They will be held by spring force and the hole will be double tapped so a pin sits flush with the side of the bushing as not to interfere with the pole and the bushing. Two loose fitting pins will attach the arms to the spinners and will stay in place due to the two washers above and below. The spinners themselves will be soldered on to twist with the hex. The final design drawing is shown below in Figure 14.

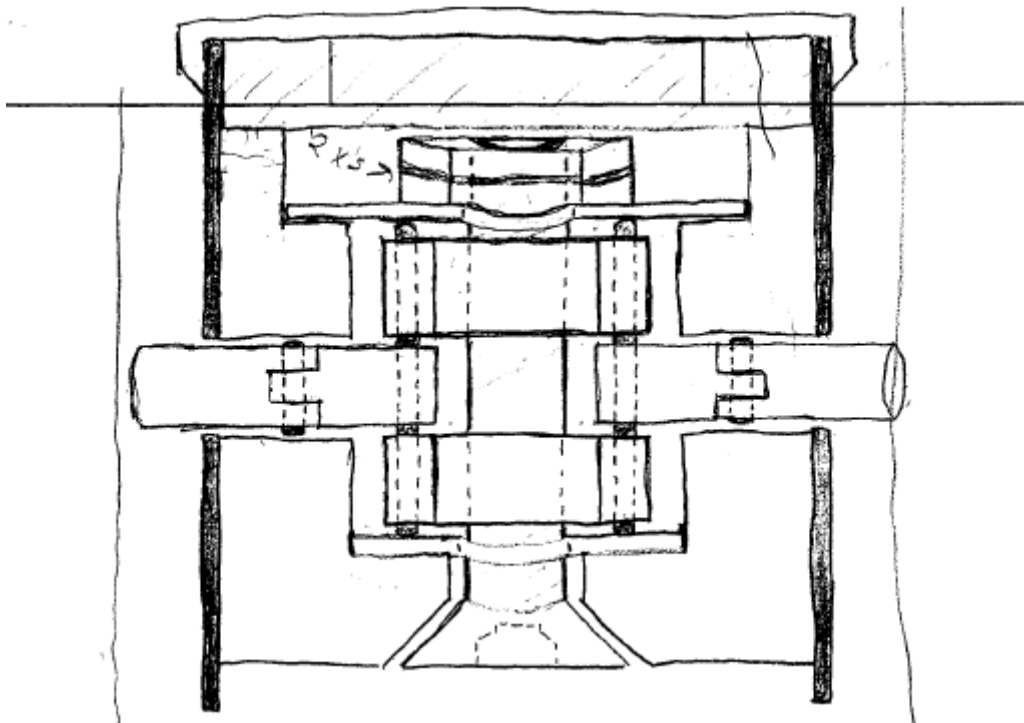

Figure 14 – Hex Nut and Spring Additions Side View

Concept 11: Bottom Segment

Due to the inner diameter size of the last pole we were using we needed to develop another locking and unlocking mechanism that was also capable of starting the collapsing sequence. Our first sketches lead us to a small horseshoe shaped component that would be pinned inside of the top of the bottom pole shown in Figure 15 below. Its two arms would stick out of two side holes drilled into the pole, similar to the style of the bushings in the other pole segments. A cable would be tied in between each arm that would be also connected in the center where another cable would be attached that would run down the shaft of the pole. The cable would come out and attach to a smaller segment of the pole which was the tip and basket of the pole. This small component would sit inside the bottom of the last pole tightly connect to the cable as to act as the trigger for the pole to collapse. Only when one was to pull on the basket component, bringing in the horseshoe arms due to tension and elastic force of the steel being used, and then push the last pole segment in, would the collapsing of all segments begin. This allowed for the bottom of the pole to be used vigorously in the snow, but only collapsed on a two motion movement that would never occur during skiing conditions.

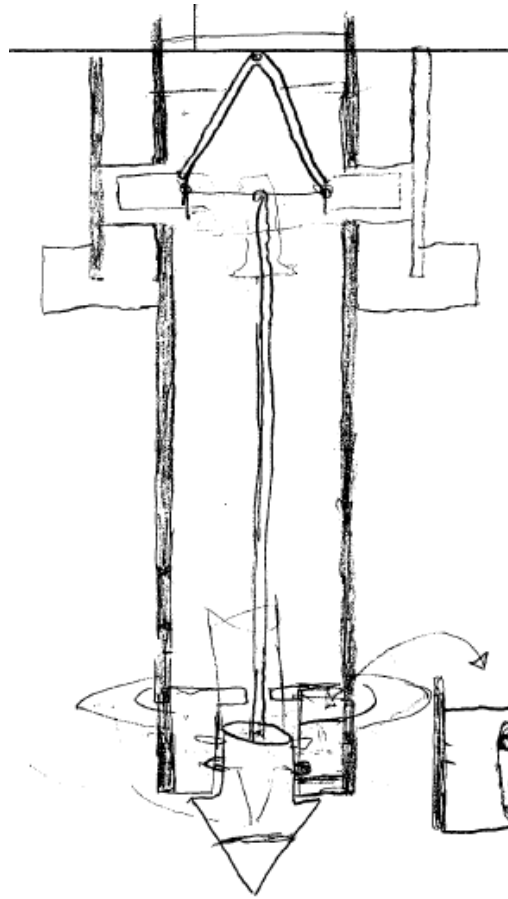

Figure 15 – Bottom Segment with Basket Release

Final Design

After completion all of the background research to get an idea for the products on the market and how they work to solve the problem at hand, different design ideas were explored. After careful deliberation in which all of the pros and cons were discussed, the group picked the final design to be the fully rotating, internal locking design. For the lowest locking mechanism, a different locking mechanism was decided upon due to the restraint on part sizes.

Preliminary Design Description:

When dealing with the wet, icy conditions experienced while snowboarding, a fully internally locking and releasing design is the best option. This eliminates the introduction of many external elements such as water and dirt that could potentially cause functional problems in the use of the pole. In the preliminary internal locking designs, each section of pole had to be rotationally fixed in order to insure that the locking mechanisms would remain lined up at all times. Given the variable loads that each pole section will experience through use, the group decided to find an internal locking mechanism in which each pole section is free to rotate.

Given this design constraint, the following design sketch was created to demonstrate how the internal locking mechanism works.

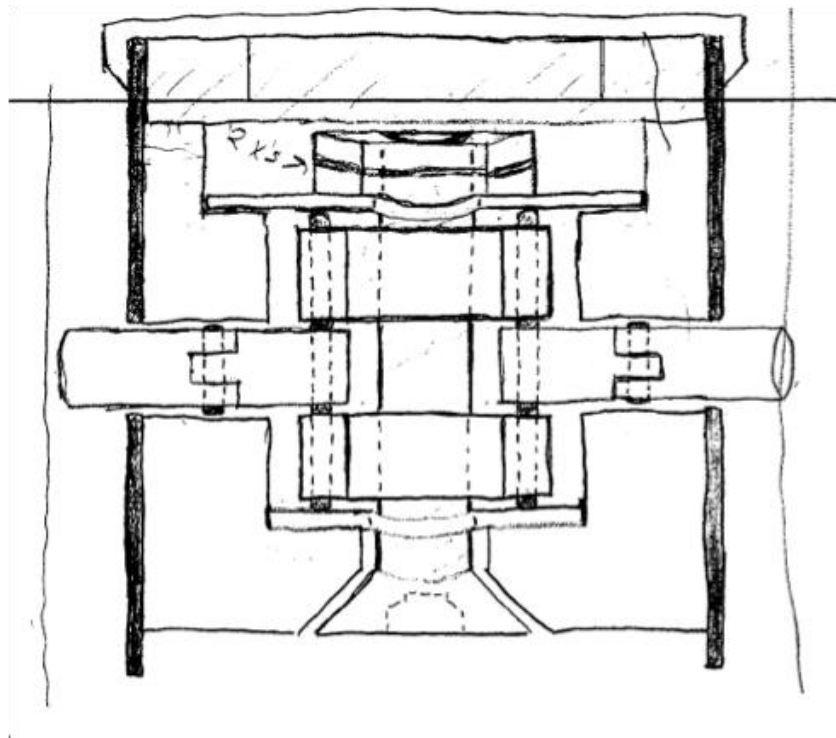

Figure 16 – Final Design Sketch of Locking Mechanism

Figure 16 above is a hand drawn image of a bushing with the locking arms protruding out each side and the internal rotating components. The hex head bolt that extends up through the

center of the bushing is free to rotate, but held in place vertically by the two nuts at the top. For machining and construction purposes, the lower pocket hole diameter is made smaller than the top pocket. A washer is used that is the diameter of the larger hole to cover the lower pocket and provide a surface for the nuts to sit on. The two components that are stacked vertically on either side of the extension arms are the spinners. These components are fixed to the bolt in order to spin when the bolt spins. The vertical pins are used to hold the arms in place between the spinners. When the bolt is turned, the spinners will turn, thus retracting the arms. Finally, the lower washer is implemented in order to provide a hard surface for the pins to rest on in order to prevent any wear on the plastic of the bushing.

This design works by the pole section below this in the assembly being released and slid up toward this bushing. At the top of the lower pole section, there is a hex key that is inserted into the hex head bolt shown in the figure above. Once the hex key is inserted in the hex head, the user manually turns the lower pole section, which turns the bolt in this bushing. This then causes the arms to retract inside of the pole wall releasing this bushing from its locked position. It is now free to collapse inside the next pole section to repeat the process.

In order for this design to work, there must be constant pressure outward on each extension arm, which is supplied through the implementation of springs. The springs will be loaded in extension when the arms are retracted. This provides the force to return the arms to the extended position when the force on the springs is released.

Making a Solid Model:

With the preliminary design sketch completed, the next step was to model the parts in SolidWorks. By creating a solid model of the parts, the dimensions can all be finalized and the

feasibility of the design can be verified. Other features of SolidWorks include the ability to make an assembly out of the individual parts to show how each individual component comes together, and after the assembly is made, the assembly can be put through a simulation to see if everything works properly.

The first order of business was to obtain the pole sections to be used for the prototype in order to figure out the dimensions that everything had to be designed for. After this was completed, solid models of the pole sections were made, and the modeling of the individual components began. Due to the fact that the design dealt with telescoping poles and small parts, the tolerances and clearances built in to the design were very important. Each section of pole needed to easily slide inside of the next section, but they cannot be too loose or the amount of deflection over the length of the pole would be too large, causing the design to fail.

With the prototype size determined, a solid model was created of the internal locking mechanisms. A full model of the completed design as well as a section view to show the interior components are shown below in Figures 17 and 18 respectively.

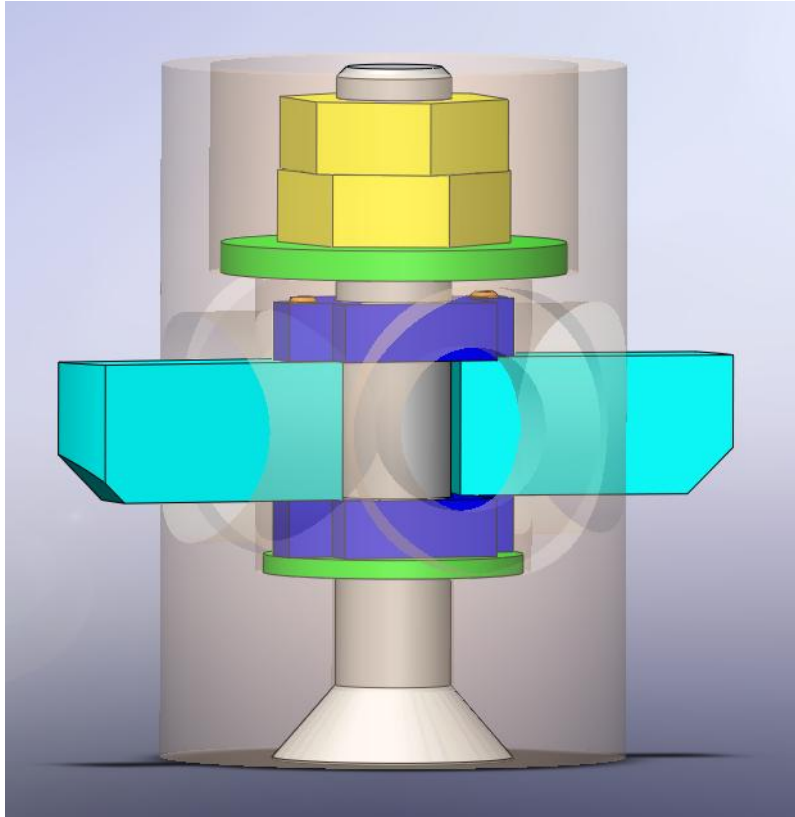

Figure 17 – Exterior View of Locking Mechanism

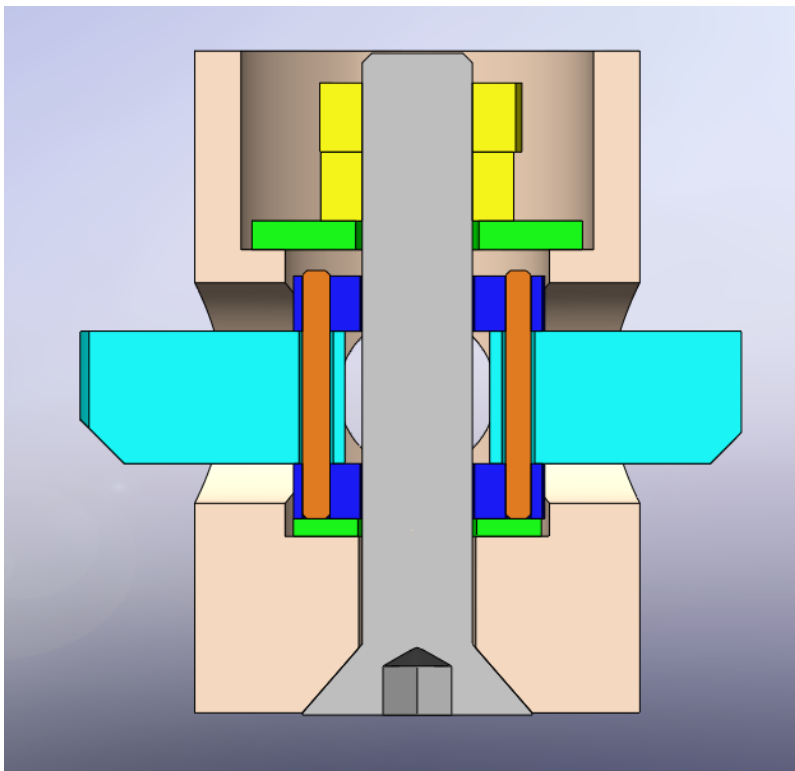

Figure 18 – Section View of Locking Mechanism

Each section of this model had to be created separately and then put together through the implementation of the SolidWorks assembly feature. Many of the components in this design could be purchased to include the washers, bolt, pins and nuts. The only parts that needed to be designed and machined were the spinners, extension arms, and the bushing.

Bushing:

Once the size constraints were determined, the modeling began. The first parts that were modeled were the two bushings that acted as the housing for the internal locking mechanisms. These bushings had to be modeled to have a tight fit on the inner diameter of the pole section it was to be mounted inside. Other things that were considered during modeling were the machinability of the parts and the size of the inner components to verify the design would work properly.

Multiple views of the bushing design are shown below that highlight the major components of the design.

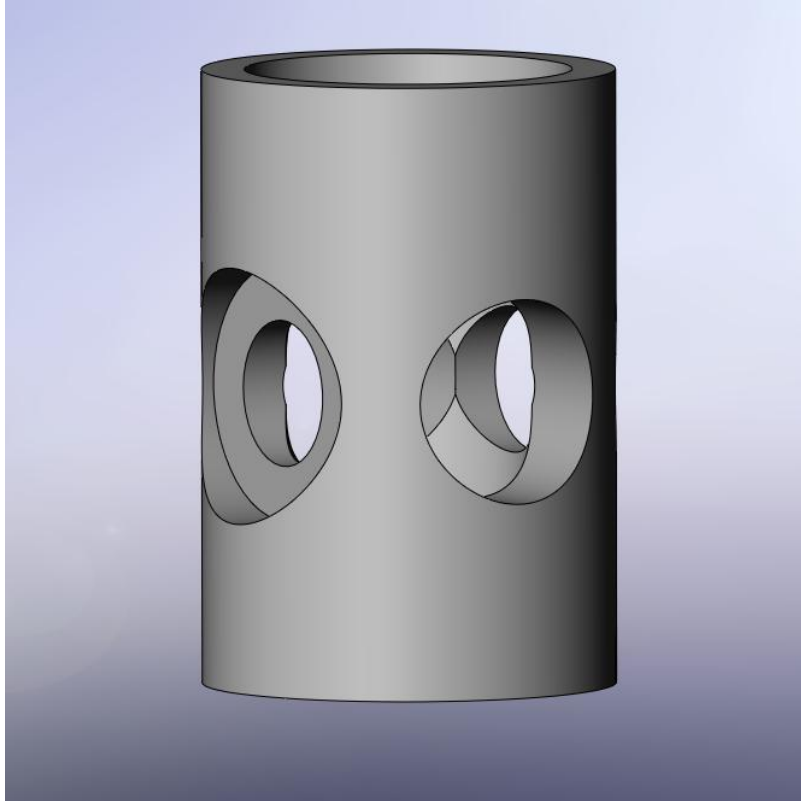

Figure 19 – Isometric View of Bushing

Figure 19 is an isometric view of the bushing design that highlights the through-hole on the right side that will serve as the exit holes for the extension arms. This hole diameter was selected to be large enough for the arms to fully retract inside of the bushing without coming in contact with the body of the bushing. This view also highlights the tapped hole on the left where the spring is installed and connected. The spring goes inside of the bushing through the through-hole and connects to the vertical pin that is inserted through the spinners, and connects to a pin that is set in the tapped hole shown above. This connection method allows for the spring pin to fully rotate without coming free and is held in place from the spring tension.

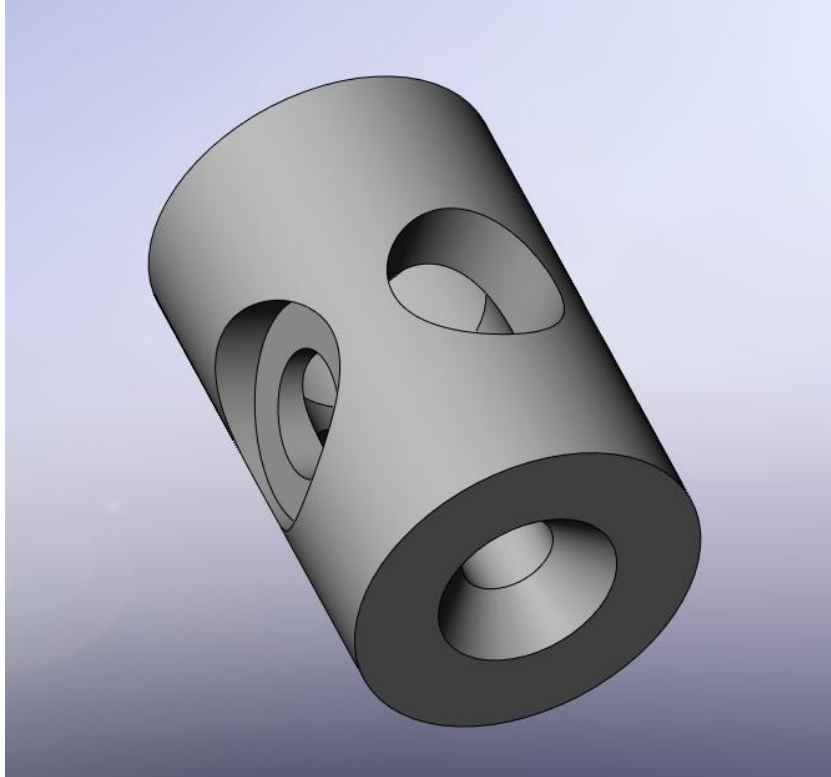

Figure 20 – Bushing View Highlighting Countersunk Bottom Hole

The major feature that is highlighted through Figure 20 is the countersunk hole on the bottom of the bushing that allows for the hex-head cap screw to sit flush to the bottom of the bushing.

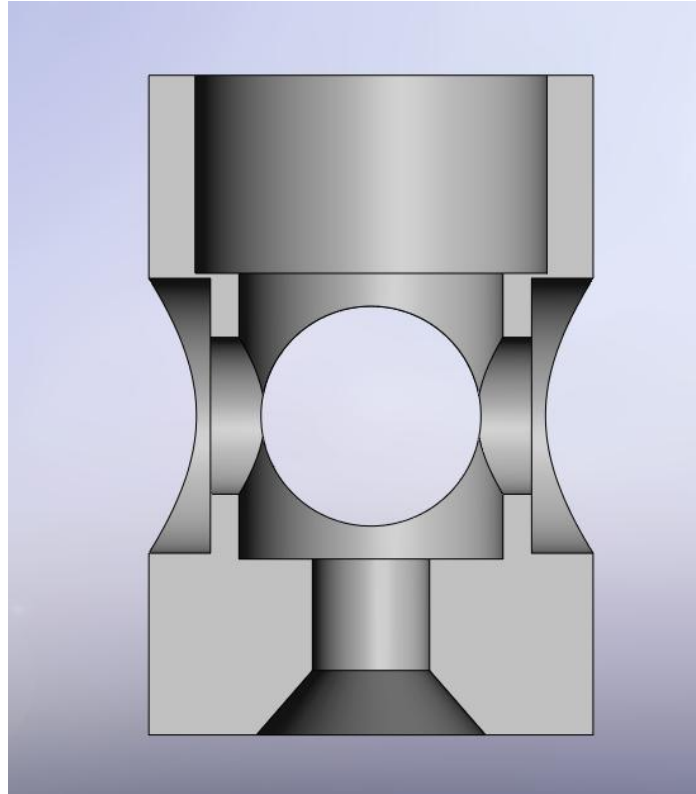

Figure 21 – Bushing Cross Section

The view in Figure 21 above is a cross-section view of the final bushing design. In this view, the pockets are visible where all of the internal moving parts are to be installed.

Spinners:

Once the bushing design was finalized, the next step was to begin modeling the inner components of the locking mechanism. The spinners, shown in dark blue in the assembly, serve as the components that hold the pins in a vertical position. They are fixed to the bolt in order to spin when the bolt is turned, thus pulling the pins in an arc around the inner pocket of the bushing and retracting the extension arms. The solid model of the spinner design is shown below in Figure 22.

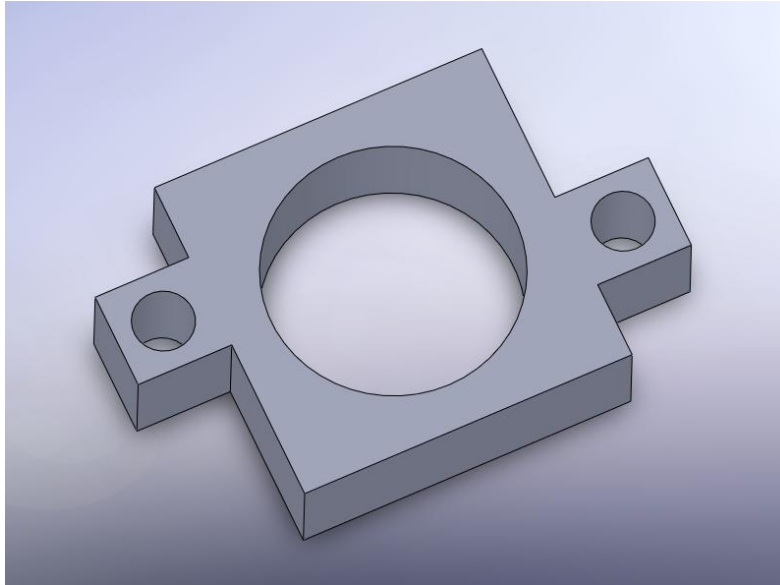

Figure 22 – Spinner Solid Model

The spinner has a large hole through the center where it is placed around the bolt, and two small holes on the extrusions where the pins are inserted. The bottom spinner rests on top of the washer, while the upper spinner rests upon the top of the extension arms.

Extension Arms:

The extension arms are shown in light blue in the assembly picture. They serve as the locking feature of the design. When extended due to the spring force, the curved end is pressed against the inner wall of the next larger pole section. The angled cut on the bottom of the arms, shown in Figure 23 below, was designed in order to aid in the automatic retraction of the arms when the user pulls the pole sections out in order to lock them in place. The angle of the arms will slide along the angle section of the ring pieces and retract inside the bushing enough to allow the pole to proceed to the area where it will lock into place.

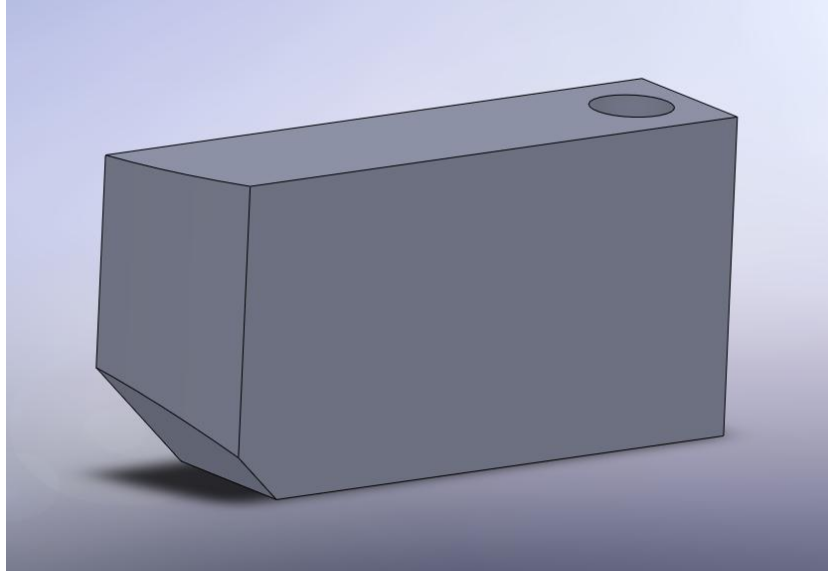

Figure 23 – Extension Arms Solid Model

When designing the arms, it was important to calculate the length of the arms accurately. The arms had to extend from the pins inside of the bushing through the pole wall that houses the bushing, and then reach the wall of the next larger pole section. It was also important to calculate this distance on an angle in order to prevent the bolt to be spun the wrong way. By having the arms fully extended in an angled fashion, this condition is avoided.

Bottom Locking Mechanism Design:

Due to the availability and feasibility of machining parts of the necessary size, the group decided to have a different locking mechanism for the lowest pole section. For this section, serious consideration had to be put into a way to release this lowest section while keeping the design constraint of having all parts fully internal.

For this design, a spring extension arm system that was released by pulling on the basket section of the pole was decided upon as the best option. The extension arms will be locked in place through the use of springs. When the user pulls on the basket section of the pole, the wire that is attached to the inside of the arms retracts them inside of the pole. This releases the locking mechanism allowing the user to then proceed to unlock the next section. A drawing of this design can be seen in Figure 24 below.

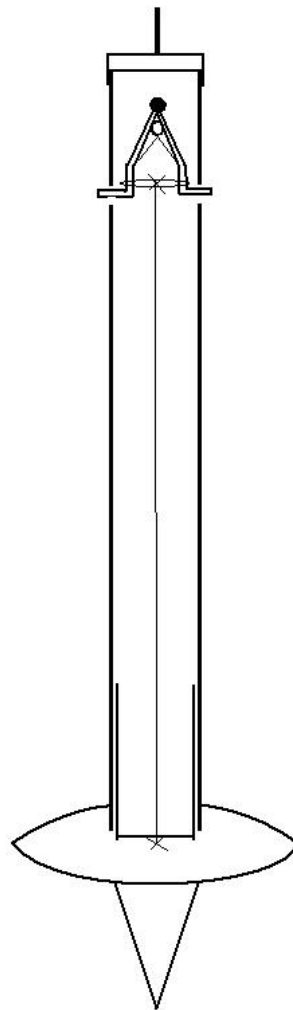

Figure 24 – Bottom Locking/Releasing Mechanism

While using a ski pole, it is common to get the basket stuck in the snow. This design allows for this to happen but will not release the pole section causing the pole to collapse in use. The reason for this is because it requires two opposing forces to disengage this locking mechanism. The user must pull outward on the basket section, while pushing in the opposite direction to release the pole from the locked position.

Adjustable Handle Design:

While completing this project, discussions sparked up about a very simple and easy way to adjust the height of the snowboard pole. This design could easily be applied to any ski pole currently on the market giving the user an extra couple inches of pole height. This could be very valuable for riders that prefer different pole lengths on different terrains, as well as users that grow over time that do not have to purchase longer poles. Another valuable asset to having an adjustable height pole is that one assembly can be used comfortably by a much larger population.

The design, shown in Figures 25 and 26 below, includes a handle grip that slides over the top pole section and a long bolt. The top of the bolt is fixed to the handle section, and free to rotate within the threaded bushing section. By using the built-in allen wrench, the user can raise or lower the bolt inside of the bushing, thus moving the handle up or down the pole.

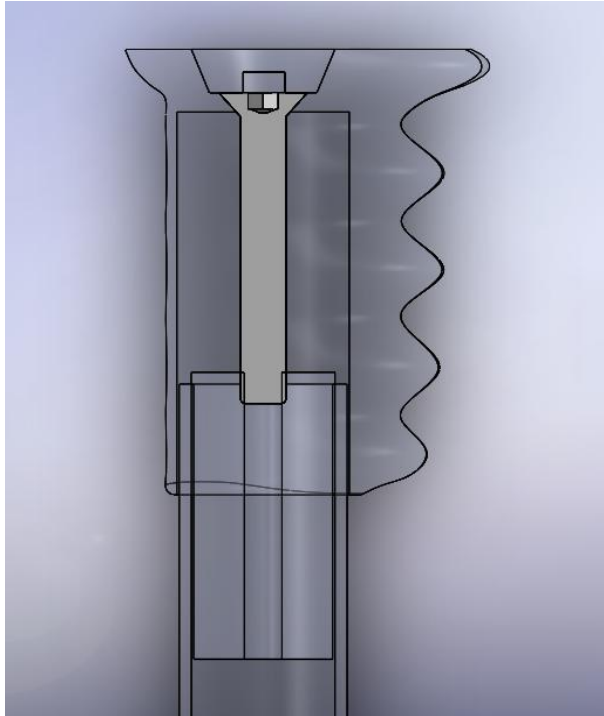

Figure 25 - Handle Adjustment Design Extended

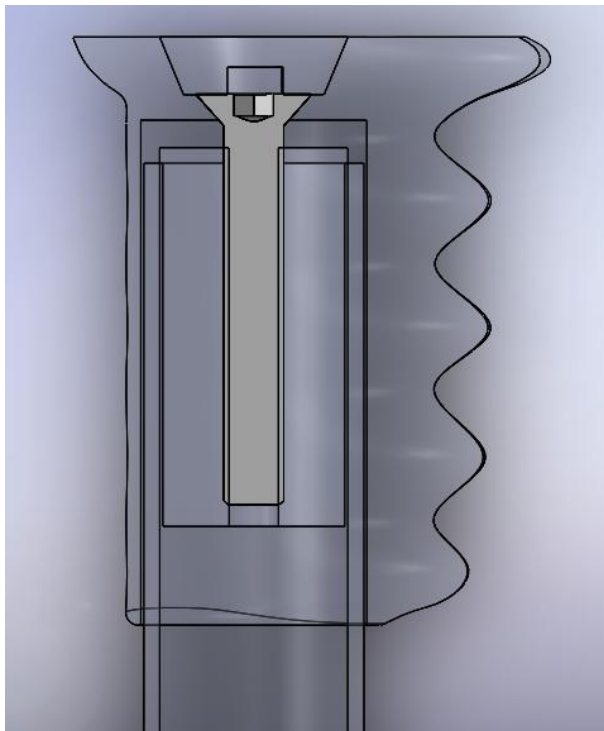

Figure 26 - Handle Adjustment Design Collapsed

Pole Storage:

While the snowboard is not in use, it needs to be stored somewhere safe and accessible. First, the feasibility of storing the collapsed pole on the snowboard was considered. Snowboards are designed to be flexible therefore a sixteen inch long rigid pole would interfere with the snowboard's functionality. Other ideas such as storage on the user's arm or back posed safety threats to the user if they happened to fall.

Storage on the inside of the lower leg provides a safe and accessible location. The pole is attached to the user between the knee and top of the snowboard which gives the user full use of their body and they still have access to the binding straps for locking and releasing their boot into the snowboard. The use of Velcro straps allows for a strong and durable attachment method that can be used in all weather conditions as well as with thick winter gloves on.

Stress Analysis:

The following analyses were completed on the design to ensure that it would meet the functional requirements set forth by the group.

Critical Load:

$$P_{cr} = \frac{\pi \cdot E \cdot I}{l^2}$$

$$E = 18.5E^6 \text{ psi}$$

$$I = 4.54307E^{-4}$$

$$l = 52 \text{ inches}$$

Given these parameters, it was calculated that the critical load for a 52 inch pole of the smallest diameter would yield a critical load at 306.77 pounds. This is the point at which the pole would begin to buckle in compression.

The forces applied on the pole will be used to propel a snowboarder across a flat or even a slight incline plane. Our goal was to develop a pole that could propel snowboards who were up to 250 lbs across a plane that had up to a 20° angle. We were able to calculate the force that would be needed to remain standing or propel the boarder up a slope.

$$\mu = \frac{F}{N}$$

$$N = \frac{m \cdot g}{\cos(\theta)}$$

$$N = \frac{W}{\cos(\theta)}$$

$$W = 250lbs$$

$$N_{\max} = \frac{250}{\cos(20)} = 266.044lbs$$

$$f = \mu \cdot N$$

$$\mu = 0.1$$

$$F_{\max} = 0.1 \cdot 266.044 = 26.604lbs$$

Bending Strength with Fixed Point:

To find the maximum bending force a single section of the pole could withstand, we calculated the most torque we could apply to the pole before failure. We considered one end of the pole to be fixed and applied force to the opposite free end:

Length of the pole = 11 inches

Outer Diameter = 5/8 inch

Ultimate stress of the pole = 81950 psi

$I = 4.543074E^{-3}$

$$\sigma_x(x, y) = \frac{-M \cdot y_{\max}}{I_{zz}}$$

$$M_{\max} = F \cdot L$$

$$y_{\max} = R_0$$

$$R_0 = 0.3125''$$

$$(\sigma_x)_{\max} \prec \sigma_{Ultimate}$$

$$\frac{F \cdot L \cdot R_0}{I_{zz}}$$

$$F = \frac{(\sigma_{Ultimate}) \cdot (I_{zz})}{L \cdot R_0}$$

$$F \prec 1083.07lbs$$

Maximum force for a 50 inch contiguous pole under the same conditions

$$F \prec 354.18lbs$$

Extent of Compression on the Polycarbonate Caps and Rings:

When working with any material that will be experiencing heavy loads, it is important to investigate the extent to which the material will compress. In this case, the polycarbonate sleeves and top caps will experience forces that will cause the material to compress. For one single section of the pole, this may not be a big deal, but it needed to be examined over the whole length of the pole in order to determine how much it will add to the overall deflection.

When a cylinder compresses, it will create a small flat edge on one side. The desired load of 350 pounds, and the contact area of a cap against the inside wall of the pole can be used to determine the stress on the polycarbonate. From this stress and the Young's Modulus of the material, the strain can be determined where the strain is the amount of compression of the material. With these values determined, multiple iterations can be done through the implementation of the following equations in order to find the balanced stress, strain, contact arc length, and contact area.

Once this contact area is determined, it is then put back in to the start of the equations as the new value for contact area. This process was repeated several times until the values were balanced enough and an accuracy of 6 decimal places was determined. The results of the calculations are shown below.

$$\sigma_{\max} = 12,500 \text{ psi}$$

$$E = 345,000 \text{ psi}$$

$$\varepsilon_{\max} = \frac{\sigma_{\max}}{E}$$

$$\varepsilon = h$$

$$S = D \cdot \text{Cos}^{-1}\left(\frac{R-h}{R}\right)$$

$$S_i = 0.3307 \text{ in}$$

Area of contact = (Cap length) x (Length of Curve in contact) =

$$A_1 = 0.14478 \text{ in}^2$$

$$\sigma_1 = \frac{F}{A}$$

$$\varepsilon_1 = \frac{\sigma}{E}$$

$$S_1 = 0.144245$$

The new S value is used to calculate A, σ , ε . After Several iterations we found that:

$$\sigma = 4197.4 \text{ psi}$$

$$\varepsilon = 0.012166$$

$$S = 0.19029$$

$$A = 0.083309 \text{ in}^2$$

Amount of deflection between each pole, and over the entire length

$$\Delta D = 0.745'' - 0.740'' = 0.005$$

$$\text{Compression} = 0.01217''$$

Compression is taken twice = 0.02434''

H = distance between points of contact of the top cap and end cap

$$\theta = \tan^{-1} \cdot \left(\frac{\Delta D \cdot 2 \times \text{Compression}}{H} \right)$$

$$\theta = 0.98876^\circ$$

The angle taken three times gives us the deflection of the entire pole

$$\theta = 2.966^\circ$$

Parts Machining and Construction

When the final designs for the bushings and poles were completed, and the material was ordered we needed to machine most of the inner components of the pole. We were able to use the stock material of polycarbonate rods, aluminum poles and aluminum sheets to machine each part. The majority of our parts were machined on a lathe or the Haas CNC machine in the Higgins machine shop.

Description of Cutting and Drilling the Parts Needed:

The first parts that we cut were the aluminum poles. We ordered 3 foot poles of 4 different diameters. We cut the poles to make two separate models of our design. Since our design involves the poles telescoping into each other, each section needed to be cut to a different length. Our top pole, which had the greatest diameter of 1.5 inches was cut to 16 inches in length. The next pole with a diameter of 1 inch was cut down to 15 inches. Our third pole was cut to 13 inches with a $\frac{3}{4}$ inch diameter, and our bottom pole was 12 inches with a $\frac{1}{2}$ inch diameter. When the pole is full extended the overlap between each pole will be 2 inches, therefore our prototype has a total length of 52 inches.

For our interior parts, we used rods of polycarbonate and shaped them to meet our requirements. The interior parts included the bushings, which is where the locking mechanism was, the collars to draw the pins into the bushings, and the top and end caps of each pole. The end caps and collars have the same inner and outer diameters, so we were able to drill out the rods, file down the outer edge, and slice each part to the desired height. The parts used for the collars were then filed to have an angle on one of the interior edges to draw the pins from the bushing in. We were able to do all of the procedures on a lathe. We gradually drilled holes in the plastic rods to a depth that we could slice the cylinder multiple times to our desired sizes. Once the holes were drilled, we filed down the inner edge of the cylinder to ensure that the next pole could freely slide through. The next step was to file down the outer edge to tight fit into their appropriate pole. After the inner and out diameters were to the exact specifications, we sliced off copies of the end caps. We then filed angles into the cylinders used for the collars. We were able to used the lathe with an angled tool to get our desired slope. The part was then sliced and the angling process was repeated for the next part.

The top caps were also made from the polycarbonate rods. Similar to the end caps and collars, we drilled the middle hole, then filed down the inner and outer edges. However, we only drilled a ½ inch into the rod, then sliced off ¾ of an inch to create the top of the cap.

Machining of Small Parts:

The final bushing design consisted of many small parts such as the spinners, arms, and springs. The washers, pins, bolts and nuts for the bushings were ordered from the online catalog McMaster Carr. The other parts needed to be made specifically to fit our design. These parts had unique shapes, and had extremely small dimensions. To create such small parts with high precision we used the Haas CNC machine. We were able to use our solid models in the computer program “Esprit”. Using Esprit, we programmed operations to be carried out by the Haas machine. We used drilling operations to create the holes for the bolts and pins in the arms and spinners. Once the holes were drilled we used a contouring operation to cut out the exact shape of each part. This process was extremely effective and efficient. We were able to develop the required parts to meet our tolerances, and create multiple copies of each part.

Bushing Assembly:

The bushing assembly is a relatively simple process designed so that with the correct instructions, anyone could assemble them. Using the polycarbonate bushing, the inner components are simply placed on the bolt inside the bushing. The first component to be placed inside the bushing is the bottom washer. After the washer is in place the bottom spinner is slid around the bolt. The arms are then pinned to the bottom spinner. Once the pins are in place, the

springs are hooked onto the exterior side pins, and the internal pins that hold the spinner and arms in place. The next step is to line the top spinner up with the interior pins, epoxy applied between the spinner and the bolt so they rotate together. The final step is to place the top washer and nuts on the bolt, and the assembly is complete. Some of the steps involved in the assembly require fine precision, especially when trying to install the very small springs. If the steps are followed properly, the bushings can be easily assembled. The final bushing assembly is shown in Figure 27 below.



Figure 27 – Prototype Bushing Assembly

Bottom Locking/Release Mechanism:

The lowest locking mechanism with a different design posed many challenges for construction. For the construction of this section, the desired part sizes were not available for purchase, so the implementation of altered drywall anchors helped to solve this problem. The drywall anchors used have the right size, as well as the interior coil spring system to lock them in the out position, which is exactly what our design called for. Holes were drilled in the lowest pole section for the extension arms to protrude through, and the locking mechanism consisting of altered drywall anchors and the coiled springs was installed inside the pole. As a releasing mechanism, wire was used to wrap around the inner edge of the arms and fed through to the end of the pole. The final connection was made at the base of the pole after the wire went through a 1 inch bushing with a single drill hole through the center. This bushing was designed to act as a way to direct the wire in the right direction, as well as act as a stop for the basket and spike section. The wire is attached at the bottom of the basket after it comes out of the pole. Shown in the image below, the basket and spike section is free to pull out of the lowest pole section, which pulls down on the wire around the arms retracting them inside of the pole. With this design, the user can simply pull downward on the basket, retracting the arms and release the pole section from the locked position. The Figures 28 and 29 below show the basket section of the pole in the extended and retracted positions, respectively.



Figure 28 – Basket Section Extended (Arms Retracted)



Figure 29 - Basket Section at Rest (Arms Extended)

Pole Assembly

In order for the pole to function properly, we needed to assemble the pole from the bottom up. Since the top caps were designed to stop the poles from extending too far and coming apart, we assembled the pole with the smallest diameter first. Once the bottom pole was assembled, the top cap was pinned on and the segment was slid into the next section. The lower bushing and top cap were then pinned on the next pole segment, and the entire unit was slid into the next pole. The upper bushing and top cap of the third pole were then pinned in place. Again, the three poles were then slid into the largest pole section. The handle bushing and handle were then tight fit on the top of the final pole segment and the assembly of the poles was completed.

Handle and Handle Bushing:

The handle for our prototype was made out of a PVC rod and the polycarbonate was used for the handle bushing. The handle was machined on the lathe by drilling a pocket in the PVC rod to fit the diameter of our largest pole segment. Once the pocket was finished we drilled a through hole on the top of the handle and counter sunk the hole. The last procedure on the handle was drilling another hole in the top of the handle to hold the allen wrench. As for the handle bushing, a 3/8" through hole was drilled through the entire part. After the hole was drilled we used a 1/2" X 13 threaded tap to thread the hole for the handle bolt. Similar to the handle the final step was to drill another hole through the bushing to fit the allen wrench key. Using a nylon patch and epoxy, the bolt was screwed into the handle and fixed in place. The handle and bolt was then screwed into the bushing, and the two nuts were screwed on to prevent the handle from being removed. The final step was to tight fit the bushing into the top of the fully assembled pole. Figures 30 and 31 show the prototype assembly extended and collapsed, respectively.



Figure 30 – Fully Assembled Prototype (Extended)



Figure 31 – Fully Assembled Prototype (Collapsed)

Testing:

The final manufactured pole was a rigid working model of the design. Each segment of the pole worked individually, but failed when the entire pole was assembled. Once the pole was assembled a variety of problems occurred. The problems occurred mainly due to the polycarbonate not being suitable to meet the functional requirements. The polycarbonate was easily deformed and chipped away by the aluminum components in the pole. The allen wrench keys were offset after a few uses because the polycarbonate had been deformed. Once the keys were offset the bushing pins could not be pulled in to unlock the next section of the pole. Another problem occurred when the aluminum pins were dragged over the rings inside each pole segment. The angle of the rings was worn away and caused difficulty with drawing the pins in to lock the pole in extension. When the pole was completely assembled, the damage on the

polycarbonate components was enough to cause the pole to not function properly. Since the polycarbonate was unable to withstand any compressive force when the pole was fully expanded, the pole did not meet our desired requirements. Both the compressive strength and bending strength could not be tested since the pole did not remain extended under its own weight. However, the actual deflection between the poles was less than the calculated theoretical angle.

Refining:

The interior locking mechanisms were all successful in meeting our functional requirements. The internal springs provided substantial force to keep the arms extended, and they were able to withstand the forces applied to draw the arms in. The overall design of each locking mechanism did not need any adjustments in order for the pole to meet the functional requirements. The largest problem that needs consideration is the selection of materials. In order to develop a successful prototype, the interior components would need to be made from different materials. We used polycarbonate plastic to make the rings, top caps, and end caps for each pole segment. We found that this material is undesirable for the prototype.

The polycarbonate had good compressive strength, was resistant to different weather conditions, and was easily machined. These qualities were the reasons we used the material for our components. However, since the plastic was easily machined, it was also easily worn away by the aluminum poles and bushing arms. Once the polycarbonate was deformed, the pole was unable to function. One potential solution would be to use a stronger material that would be more resistant to wear.

Conclusions

An effective method of collapsing and expanding the snowboard pole was created by the design of the inner bushings. These small cylindrical shaped mechanisms hold very small parts that consist of a main bolt, spinners, extension arms, small springs, washers, pins, and nuts. The main bolt's head is the female end of which a male allen wrench head can mate to activate the action inside the bushing itself. After the initial collapsing of the pole occurs at the basket section, the top of the lowest pole segment then slides into the next segment. The top of the lower bushing is equipped with the male head that comfortably slides in the female head of the bolt. By slightly twisting the pole segment in this position the arms within the bushing are retracted from their locked positions and then this newly collapsed segment is free to repeat the same actions on the next segment.

To expand the pole, the snowboarder can simply pull out the lowest segment from its basket. The other segments of the pole will follow with this one action. Internally, automatic locking will occur when the arms of the bushing fit into the built in gap. The arms will remain locked out due to the spring force on the inside of the bushing until the collapsing sequence is started.

The greatest achievement of our project was the development of a functional locking mechanism for telescoping poles. The overall performance of the pole did not meet our functional requirements, but the locking mechanism did. We were able to design and construct an automatic locking system that can be used in a variety of telescoping poles. The bushings were durable, and the locking and unlocking mechanism worked well even with repeated use.

The pins were held out in position by the springs with substantial force in both the upper and lower bushings. With the use of the allen wrench keys, the pins were easily drawn in.

Although the bushing is the main design feature of this pole, there is another mechanism that adds to the appeal of this product. The handle consists of a threaded bushing, which holds a large hex bolt. This bolt is attached to the handle, and when accessed can be turned to adjust the handle up & down along the top pole segment easily & without losing integrity. This height adjustment feature allows for a range of riders for just one pole.

References

<http://www.freepatentsonline.com/4424987.html>

<http://www.freepatentsonline.com/5387048.pdf>

<http://www.patentstorm.us/patents/6938927-description.html>

<http://www.carbonfibertubeshop.com/tube%20properties.html>

<http://www.technicalproductsinc.com/plastics%20chart.htm>

Appendices

None