

DESIGN OF A 16-BIT 10MHZ PIPELINE ADC USING THE SPLIT-ADC ARCHITECTURE IN 0.25 μ CMOS

A Major Qualifying Project

submitted to the Faculty

of the

WORCESTER POLYTECHNIC INSTITUTE

in partial fulfillment of the requirements for the

Degree of Bachelor of Science

in

Electrical and Computer Engineering

on

October 15, 2007

Abhilash Nair
Electrical & Computer Engineering
Computer Science

Sanjeev Goluguri
Electrical & Computer Engineering

Professor John McNeill
Advisor

Abstract

This paper discusses the design of a 16-bit 10MHz pipeline Analog to Digital Converter (ADC) using the “Split ADC architecture”. A system and circuit level design of each component of the ADC was created in Cadence. Features of the ADC were simulated in Matlab to test and examine its basic functionality. Transient analysis of the system level design was conducted to verify the performance of the ADC. Methods to correct non-linearities were identified and investigated.

Tables of Contents

1. INTRODUCTION	1
2. BACKGROUND INFORMATION.....	2
2.1. ANALOG TO DIGITAL CONVERTERS (ADCs)	2
2.2. PIPELINE ADC	5
2.3. PRIOR WORK	8
3. SYSTEM-LEVEL CHARACTERIZATION OF A PIPELINE ADC.....	10
3.1. LINEAR VS. NON-LINEAR GAIN STAGE	10
3.2. NON-LINEARITY OF SIMULATED ADC.....	13
3.3. CUBIC APPROXIMATION OF SIMULATED ADC	14
3.4. CUBIC APPROXIMATION OF SIMULATED DATA FROM CADENCE	16
3.5. DIGITAL LOOK-UP TABLE.....	18
4. CIRCUIT-LEVEL SIMULATION OF THE ANALOG SUBSYSTEM.....	21
4.1. BASIC DIFFERENTIAL PAIR CIRCUIT.....	21
4.2. CASCODE DIFF-PAIR WITH PI-RESISTOR NETWORK	28
4.3. COMMON MODE FEEDBACK & REPLICIA BIAS	36
4.4. DIFF-PAIR SETTLING TIME	41
4.5. SWITCHED CAPACITOR NETWORK.....	45
5. QUANTIZER	53
6. CONCLUSION.....	55

7. REFERENCES	56
APPENDIX A: MATLAB CODE	57
<i>I. Simulating a linear multi-stage ADC.....</i>	<i>57</i>
<i>II. Estimating V_{in} and ADC error from each stage</i>	<i>58</i>
<i>III. Simulating a non-linear multi stage ADC.....</i>	<i>59</i>
<i>IV. Simulated data from Cadence showing non-linearity</i>	<i>60</i>
<i>V. Correcting non-linearity of a simulated multi-stage ADC.....</i>	<i>61</i>
<i>VI. Correcting non-linearity of simulated data from Cadence</i>	<i>62</i>
<i>VII. Simulating the basics of a Split-ADC architecture.....</i>	<i>64</i>
<i>VIII. Simulating non-linearity from Cadence using Split-ADC architecture</i>	<i>67</i>
<i>IX. Simulating non-linearity in the first stage of Split ADC.....</i>	<i>70</i>
<i>X. Correcting non-linearity of a Split-ADC architecture</i>	<i>73</i>
<i>XI. Using Split ADC to test convergence</i>	<i>74</i>
<i>XII. Digital Look Up Table Algorithm.....</i>	<i>82</i>
<i>XIII. Analyzing Data</i>	<i>83</i>
APPENDIX B: DESIGN OF A BASIC DIFF-PAIR CIRCUIT FOR VARIOUS V_{ov}.....	87
APPENDIX C: DESIGN OF A CASCODE DIFF-PAIR WITH SPLIT CURRENT APPROACH	88

Table of Figures

FIGURE 1: BASIC FEATURE OF AN ANALOG TO DIGITAL CONVERSION [2].....	2
FIGURE 2: ILLUSTRATION OF THE QUANTIZATION PROCESS [2]	3
FIGURE 3: TRANSFER FUNCTION OF AN IDEAL ADC [2]	3
FIGURE 4: SYSTEM BLOCK OF A PIPELINE ADC.....	5
FIGURE 5: PRIOR WORK - PROPOSED OPEN LOOP PIPELINE STAGE [4].....	8
FIGURE 6: OUTPUT CODE OF STAGE 1.....	10
FIGURE 7: DIFFERENCE BETWEEN A LINEAR AND A NON-LINEAR GAIN STAGE	11
FIGURE 8: HISTOGRAM OF CODE LEVELS FOR A LINEAR GAIN STAGE	11
FIGURE 9: HISTOGRAM OF CODE LEVELS FOR A NON-LINEAR GAIN STAGE	12
FIGURE 10: DIFFERENCE IN ERROR OF A LINEAR AND NON-LINEAR GAIN STAGE	12
FIGURE 11: MEASURING NON-LINEARITY IN SIMULATED DATA.....	13
FIGURE 12: CUBIC APPROXIMATION OF SIMULATED DATA	14
FIGURE 13: DIFFERENCE IN NON-LINEARITY BEFORE AND AFTER CUBIC APPROXIMATION	14
FIGURE 14: CASCODE DIFF-PAIR WITHOUT COMMON MODE FEEDBACK OR REPLICA BIAS	16
FIGURE 15: CASCODE DIFF-PAIR WITH COMMON MODE FEEDBACK AND REPLICA BIAS.....	16
FIGURE 16: PERCENTAGE ERROR OF DLT	18
FIGURE 17: ESTIMATED VIN VS. ACTUAL VIN FROM DLT	19
FIGURE 18: ABSOLUTE ERROR FROM DLT.....	19
FIGURE 19: STAGE 1 IMPLEMENTATION OF PIPELINE ADC [4].....	21
FIGURE 20: CIRCUIT SCHEMATIC OF A SIMPLE DIFF-PAIR	22

FIGURE 21: BASIC DIFF-PAIR OUTPUT CHARACTERISTICS FOR 4 DIFFERENT V_{OV}	23
FIGURE 22: RESIDUE PLOT FOR AN OVERDRIVE VOLTAGE OF 150mV.....	25
FIGURE 23: RESIDUE PLOT FOR AN OVERDRIVE VOLTAGE OF 200mV.....	25
FIGURE 24: RESIDUE PLOT FOR AN OVERDRIVE VOLTAGE OF 250mV.....	26
FIGURE 25: RESIDUE PLOT FOR AN OVERDRIVE VOLTAGE OF 300mV.....	26
FIGURE 26: BASIC DIFF-PAIR OUTPUT VERSUS INPUT FOR VARIOUS OVERDRIVE VOLTAGES.....	28
FIGURE 27: ILLUSTRATION OF CASCODE HIGH OUTPUT IMPEDANCE.....	29
FIGURE 28: SIMPLE COMMON SOURCE CIRCUIT.....	30
FIGURE 29: CASCODED COMMON SOURCE CIRCUIT.....	30
FIGURE 30: COMPARISON OF CASCODE AND NON-CASCODE DIFF-PAIR OUTPUT CHARACTERISTICS.....	30
FIGURE 31: SMALL SIGNAL GAIN COMPARISON OF CASCODE AND NON-CASCODE DIFF-PAIR.....	31
FIGURE 32: CASCODE DIFF-PAIR WITH PI-RESISTOR NETWORK.....	32
FIGURE 33: CASCODED DIFF-PAIR DIFFERENTIAL OUTPUT VERSUS INPUT CHARACTERISTIC.....	33
FIGURE 34: CASCODED DIFF-PAIR RESIDUE PLOT.....	34
FIGURE 35: CIRCUIT SCHEMATIC OF CASCODED DIFF-PAIR WITH CMFB AND REPLICA BIAS.....	37
FIGURE 36: BIAS CIRCUIT FOR DIFF-PAIR AND CMFB.....	38
FIGURE 37: OUTPUT VS. INPUT FOR CASCODE DIFF-PAIR WITH CMFB AND REPLICA BIAS.....	39
FIGURE 38: DIFFERENTIAL OUTPUT VERSUS DIFFERENTIAL INPUT FOR CASCODE DIFF-PAIR WITH CMFB.....	40
FIGURE 39: OPERATING POINT GAIN FOR A CASCODE DIFF-PAIR WITH CMFB & REPLICA BIAS.....	40
FIGURE 40: TEST CIRCUIT FOR MEASURING SETTLING TIME OF DIFF-PAIR.....	41
FIGURE 41: SETTLING TIME PERFORMANCE INPUT AND OUTPUT VOLTAGE.....	42
FIGURE 42: RISE-TIME MEASUREMENT.....	43

FIGURE 43: FALL-TIME MEASUREMENT	43
FIGURE 44: AC SIMULATION OF DIFFERENTIAL PAIR	44
FIGURE 45: SWITCHED-CAPACITOR NETWORK SCHEMATIC	46
FIGURE 46: CLOCK SIGNALS FOR SCN	49
FIGURE 47: TRANSIENT ANALYSIS OF SCN	50
FIGURE 48: SCHEMATIC OF SWITCHED CAPACITOR NETWORK AND DIFF-PAIR TOGETHER	51
FIGURE 49: TRANSIENT ANALYSIS OF SWITCHED CAPACITOR NETWORK AND DIFF-PAIR TOGETHER	52
FIGURE 50: PREAMP FOR THE QUANTIZER	53
FIGURE 51: ALTERNATIVE APPROACH FOR QUANTIZER	54

List of Tables

TABLE 1: SUMMARY OF VARIOUS ADC ARCHITECTURES [3]	4
TABLE 2: OVERDRIVE VOLTAGE RESIDUE RESULTS SUMMARY	27
TABLE 3: SUMMARY OF CASCODE DIFF-PAIR PARAMETERS	33
TABLE 4: TRUTH TABLE FOR DAC SIGNALS.....	47
TABLE 5: CIRCUIT PARAMETERS FOR BASIC DIFFERENTIAL PAIR CIRCUIT	87
TABLE 6: COMPONENT PARAMETERS FOR DIFF-PAIR WITH CMFB AND REPLICA BIAS	89

1. Introduction

Analog to Digital Converters (ADCs) are vital components in modern microelectronic digital communication systems. Recent advances in CMOS fabrication technology has led to the implementation of more signal-processing functions in the digital domain for a lower cost and higher yield. This has generated a great demand for low-power low-voltage ADCs that can be realized in a deep-submicron CMOS technology.

The goal of this Major Qualifying Project is to design and fabricate a 16-bit 10MHz Pipeline Analog to Digital Converter (ADC) using 0.25 μ m CMOS. The motivation for designing a Pipeline ADC comes from the desire to characterize and test the functionality of the novel “Split ADC” Architecture concept [1] using a non-Algorithmic ADC.

The major tasks involved in this project include:

- System-level characterization of a Pipeline ADC
- Circuit-level simulation of analog subsystem
- Layout and fabrication of Integrated Circuit (IC)
- Implementation of digital functionality
- IC testing and data acquisition

This report contains information regarding our design, simulation results and conclusions drawn. In addition, it outlines prior work in this field and lays out a tentative agenda for the future of this project.

2. Background Information

The purpose of this section is to provide an introduction to the key issues relevant to our project. The first section covers ADCs, followed by Pipeline ADCs, and prior work.

2.1. Analog to Digital Converters (ADCs)

An ADC translates real-world continuous analog signals such as temperature, pressure and voltage into a digital representation that can be processed, transmitted and stored.

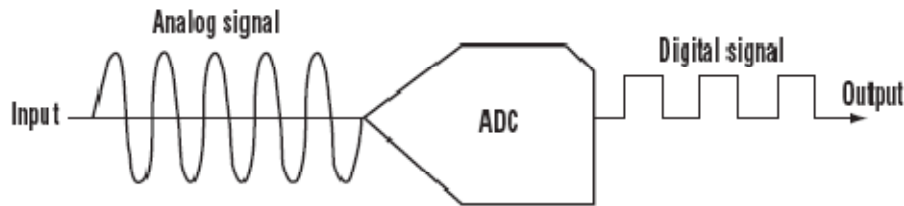

Figure 1: Basic Feature of an Analog to Digital Conversion [2]

Simply put, an ADC samples an analog waveform at uniform time intervals and assigns a digital value to each sample. This digital representation, given by the ratio of the actual voltage signal to a reference voltage, is an approximation of the original analog signal:

$$\text{Digital Code} = \frac{V_A}{V_{\text{ref}}} * (2^N - 1) = b_1 2^{-1} + b_2 2^{-2} + \dots b_N 2^{-N}$$

where V_A is the analog voltage signal, V_{ref} is a reference voltage, N is the ADC resolution, and b is the binary coefficient that has a value 0 or 1. Clearly the accuracy of an analog signal's digital representation is improved by using more bits at the ADC output.

During conversion, the signal is effectively quantized into one of a finite number of discrete levels separated by one Least Significant Bit (LSB) of the digital code as shown below. This process, also known as Quantization, results in a finite resolution

known as the Quantization Error (Q.E), which is given by $0 \leq |Q.E| \leq \frac{V_{ref}}{2^{N+1}}$

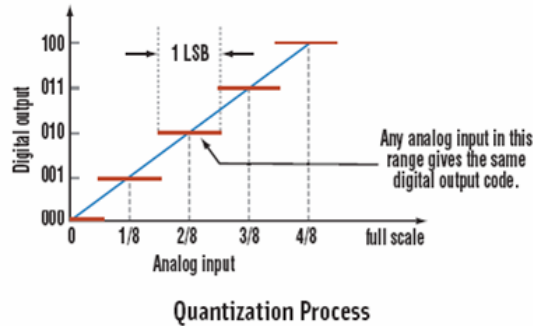

Figure 2: Illustration of the Quantization Process [2]

Sampling and Quantization determine the properties of an ideal ADC. In an ideal ADC, the code transitions are exactly 1 Least Significant Bit (LSB) apart as shown in the figure below. Therefore an N-bit ADC will have 2^N codes and conversely, $1 \text{ LSB} = \text{Input Full Scale Range} / 2^N$. In the real world, however, ADC performance is hindered by non-ideal effects, which produce errors beyond those dictated by converter resolution and sampling rate.

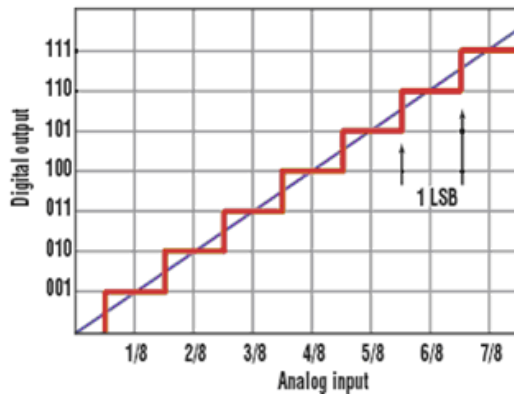

Figure 3: Transfer Function of an Ideal ADC [2]

There are many different ADC designs, but they all fall under two categories, Nyquist Rate or Over-sampled converters. Nyquist rate converters sample signals at the minimum sampling rate, whereas over-sampled converters take more samples than required to achieve high resolution. The table below summarizes different ADC architectures:

Table 1: Summary of Various ADC Architectures [3]

Low-to-Medium Speed, High Accuracy	Medium Speed, Medium Accuracy	High Speed, Low-to-Medium Accuracy
Integrating	Successive Approximation	Flash
Oversampling	Algorithmic	Two-Step
		Interpolating
		Folding
		Pipeline
		Time-Interleaved

The novel “Split ADC” architecture [1] was implemented using an Algorithmic ADC due to its reasonably quick conversion time, yet moderate complexity. The goal of this project is to characterize the performance of the “Split ADC” architecture using a Pipeline ADC, which has higher accuracy at the expense of speed. The next section covers the functionality of a pipeline ADC in detail.

2.2. Pipeline ADC

The system block diagram of our pipeline ADC is shown in the figure below.

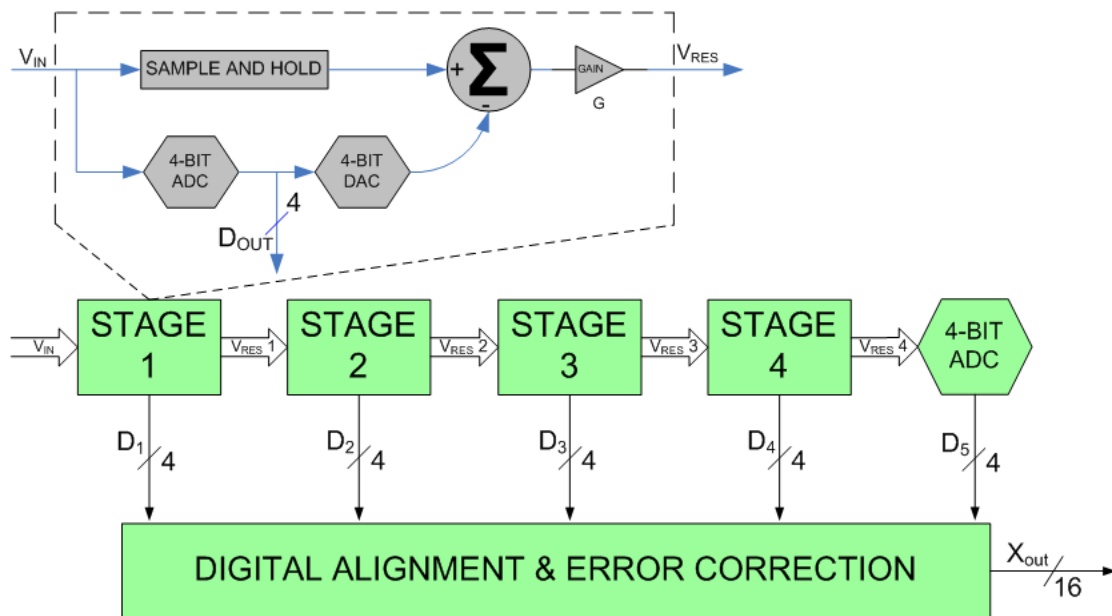

Figure 4: System Block of a Pipeline ADC

Our pipeline ADC consists of four stages and a final 4-bit flash ADC. Each stage produces 4-bits with a 1-bit overlap, hence an effective 3-bits. As a result, the four stages together yield an effective 12-bits. The final 4-bit flash ADC supplies the last 4-bits of the total 16-bits that are required from our pipeline ADC.

The advantage of using a pipeline ADC is that two or more operations can be carried out concurrently. Although the complete conversion of an analog input voltage to a digital value takes several cycles through various stages, the later stage of converting one analog voltage can be conducted simultaneously with an earlier stage of a subsequent conversion.

In each stage of the pipeline ADC, the first step is to convert the analog input voltage to a discrete value. This is carried out through a 4-bit flash ADC. This discrete value is then sent through a Digital to Analog Converter (DAC) to compare with the

actual input voltage of that stage. Any difference between the input voltage and the voltage that results from DAC indicates the error that results from both the ADC and DAC processes. This error is then amplified by an appropriate gain factor to ensure that the voltage range of the error does not become too small and is then sent to the subsequent stage of the pipeline ADC as the input voltage to the next stage.

For an ideal linear gain stage pipeline ADC, the following equations can be derived:

$$\begin{aligned}
 V_{RES1} &= G_1(V_{IN1} - D_1V_{REF}) \Rightarrow \text{Stage 1} \\
 V_{RES2} &= G_2(V_{RES1} - D_2V_{REF}) \Rightarrow \text{Stage 2} \\
 V_{RES2} &= G_2(G_1(V_{IN1} - D_1V_{REF}) - D_2V_{REF}) \\
 V_{RES3} &= G_3(V_{RES2} - D_3V_{REF}) \Rightarrow \text{Stage 3} \\
 V_{RES3} &= G_3(G_2(G_1(V_{IN1} - D_1V_{REF}) - D_2V_{REF}) - D_3V_{REF}) \\
 V_{RES4} &= G_4(V_{RES3} - D_4V_{REF}) \Rightarrow \text{Stage 4} \\
 V_{RES4} &= G_4(G_3(G_2(G_1(V_{IN1} - D_1V_{REF}) - D_2V_{REF}) - D_3V_{REF}) - D_4V_{REF}) \\
 V_{RES4} &= G_4G_3G_2G_1V_{IN1} - G_4G_3G_2G_1D_1V_{REF} - G_4G_3G_2D_2V_{REF} - G_4G_3D_3V_{REF} - G_4D_4V_{REF} \\
 \frac{V_{RES4}}{V_{REF}G_4G_3G_2G_1} &= \frac{V_{IN}}{V_{REF}} - \left[D_1 + \frac{D_2}{G_1} + \frac{D_3}{G_1G_2} + \frac{D_4}{G_1G_2G_3} \right] \\
 \frac{V_{IN}}{V_{REF}} &= \underbrace{\left[D_1 + \frac{D_2}{G_1} + \frac{D_3}{G_1G_2} + \frac{D_4}{G_1G_2G_3} \right]}_{\text{IDEAL CODE}} + \underbrace{\frac{V_{RES4}}{V_{REF}G_4G_3G_2G_1}}_{\text{QUANTIZATION NOISE}} \dots \text{(Eqn 1)}
 \end{aligned}$$

As shown in the above equation, the input voltage of a pipeline ADC can be represented as the ideal output of the ADC as well as the quantization noise from the residue of the fourth stage of an ADC.

Apart from quantization errors, ADCs also have non-linearity factors that are a result of the physical imperfections from the components that characterize the ADC. For

example, a differential pair circuit (that is used to amplify the error of a pipeline ADC stage) does not have a perfectly linear gain stage between any range of input voltages. These non-linearity factors affect the output of the ADC stages and hence also the equations above. Taking into consideration non-linearity errors, the above equations can be rewritten as shown below.

$$\begin{aligned}
 V_{RES1} &= G_1(V_{IN1} - D_1V_{REF}) + V_{NE1} \Rightarrow \text{Stage 1} \\
 V_{RES2} &= G_2(V_{RES1} - D_2V_{REF}) + V_{NE2} \Rightarrow \text{Stage 2} \\
 V_{RES2} &= G_2(G_1(V_{IN1} - D_1V_{REF}) + V_{NE1} - D_2V_{REF}) + V_{NE2} \\
 V_{RES3} &= G_3(V_{RES2} - D_3V_{REF}) + V_{NE3} \Rightarrow \text{Stage 3} \\
 V_{RES3} &= G_3(G_2(G_1(V_{IN1} - D_1V_{REF}) + V_{NE1} - D_2V_{REF}) + V_{NE2} - D_3V_{REF}) + V_{NE3} \\
 V_{RES4} &= G_4(V_{RES3} - D_4V_{REF}) + V_{NE4} \Rightarrow \text{Stage 4} \\
 V_{RES4} &= G_4(G_3(G_2(G_1(V_{IN1} - D_1V_{REF}) + V_{NE1} - D_2V_{REF}) + V_{NE2} - D_3V_{REF}) + V_{NE3} - D_4V_{REF}) + V_{NE4} \\
 V_{RES4} &= G_4G_3G_2G_1V_{IN1} - G_4G_3G_2G_1D_1V_{REF} + G_4G_3G_2V_{NE1} - G_4G_3G_2D_2V_{REF} + G_4G_3V_{NE2} - \\
 &\quad G_4G_3D_3V_{REF} + G_4V_{NE3} - G_4D_4V_{REF} + V_{NE4} \\
 \frac{V_{RES4}}{V_{REF}G_4G_3G_2G_1} &= \frac{V_{IN}}{V_{REF}} - \left[D_1 + \frac{D_2}{G_1} + \frac{D_3}{G_1G_2} + \frac{D_4}{G_1G_2G_3} \right] + \frac{1}{V_{REF}} \left[\frac{V_{NE1}}{G_1} + \frac{V_{NE2}}{G_1G_2} + \frac{V_{NE3}}{G_1G_2G_3} + \frac{V_{NE4}}{G_1G_2G_3G_4} \right] \\
 \frac{V_{IN}}{V_{REF}} &= \underbrace{\left[D_1 + \frac{D_2}{G_1} + \frac{D_3}{G_1G_2} + \frac{D_4}{G_1G_2G_3} \right]}_{\text{IDEAL CODE}} - \underbrace{\frac{1}{V_{REF}} \left[\frac{V_{NE1}}{G_1} + \frac{V_{NE2}}{G_1G_2} + \frac{V_{NE3}}{G_1G_2G_3} + \frac{V_{NE4}}{G_1G_2G_3G_4} \right]}_{\text{NON-LINEARITY ERROR}} + \underbrace{\frac{V_{RES4}}{V_{REF}G_4G_3G_2G_1}}_{\text{QUANTIZATION NOISE}} \dots \text{ (Eqn 2)}
 \end{aligned}$$

Equation 2 indicates that the input voltage can be represented by the ideal code, the quantization error as well as the non-linearity error. The non-linearity expression takes into account the non-linearities of each stage of the ADC.

As each stage of the ADC produces its output a little later than the previous stage, the output codes have to be digitally time aligned with the help of an FPGA. The FPGA will also be used to correct the above non-linearities.

2.3. Prior Work

A 12-bit 75-MS/s Pipeline ADC using Open-Loop Residue Amplification was proposed [4] to do digital background calibration. This technique is used as an enabling element to replace precision amplifiers by simple power power-efficient open-loop stages. A key difference between [4] and previous closed-loop designs is that the residual charge packet on the capacitive array is not redistributed onto a feedback capacitor, but is fed directly into a resistively loaded diff-pair to produce the desired full-swing residue voltage.

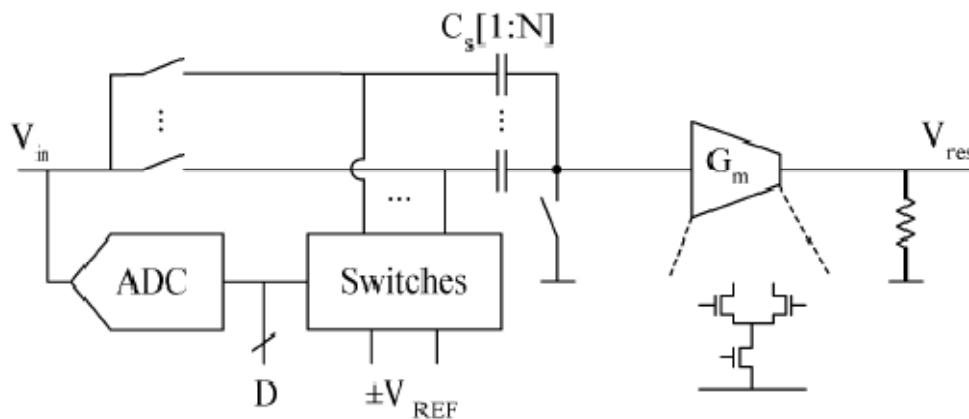

Figure 5: Prior Work - Proposed Open Loop Pipeline Stage [4]

The high gain requirement in the transconductor is dropped, resulting in a simple power efficient amplifier topology with improved deep-submicron compatibility. The non-idealities that arise from the resistively loaded diff-pair stage are corrected digitally, thereby moving complexity into the digital domain, which is the preferred tradeoff in IC Design.

The work in [4] uses a 3V supply rail, and a 0.35 μ CMOS process. In addition, the 1st stage implementation is used to implement a 12-bit 100MHz Pipeline ADC. Our

design is different from [4] in that a 2.5V supply and a 0.25 μ process are used to design a 16-bit 10 MHz Pipeline ADC.

3. System-Level Characterization of a Pipeline ADC

Both linear and non-linear gain stages of an ADC were simulated using Matlab.

3.1. Linear vs. Non-Linear Gain Stage

Appendix A1 contains the code that was used to simulate a 16-bit (16 levels) 3-stage pipeline ADC. The figure below illustrates the output code of stage 1 as a function of the analog input voltage. The figure clearly shows the 16 different levels that are associated with this ADC.

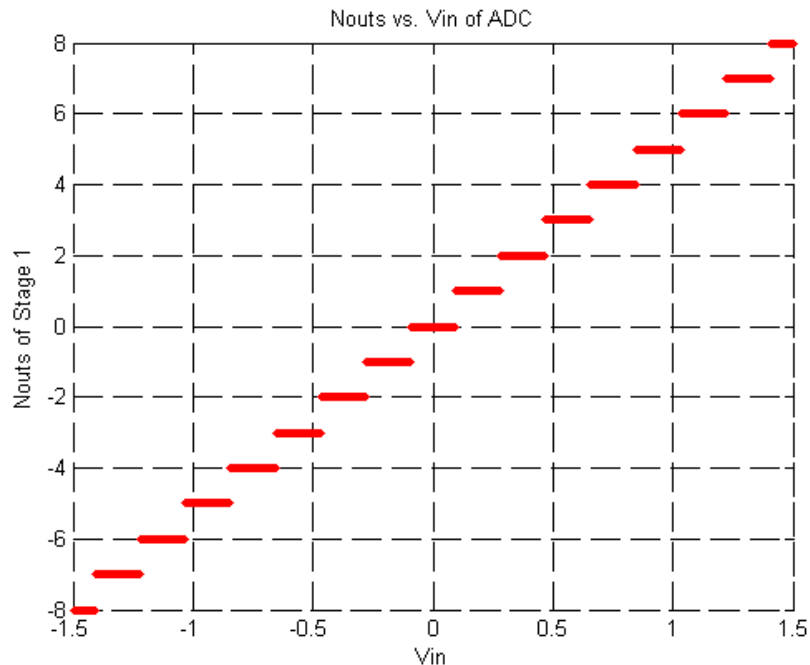

Figure 6: Output Code of Stage 1

The general difference between these two kinds of gain stages is shown in the figure below. Around the edges of each level, codes begin to deviate away from a general linear relationship between the input voltage to any stage and the analog input voltage of the pipeline ADC.

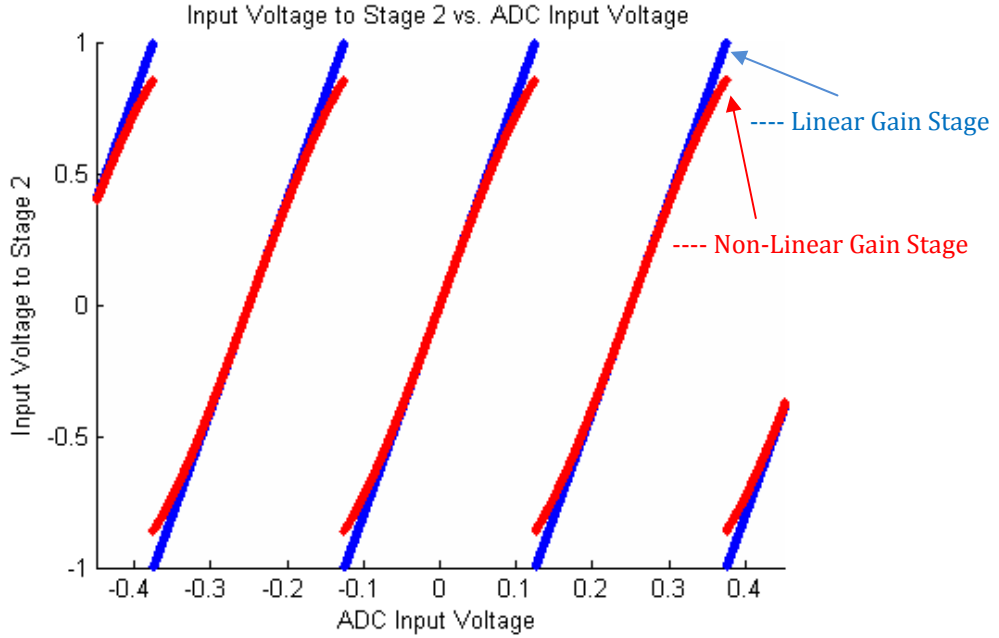

Figure 7: Difference Between a Linear and a Non-Linear Gain Stage

In a linear gain stage, each code gets hit relatively the same number of times. This is shown in the figure below.

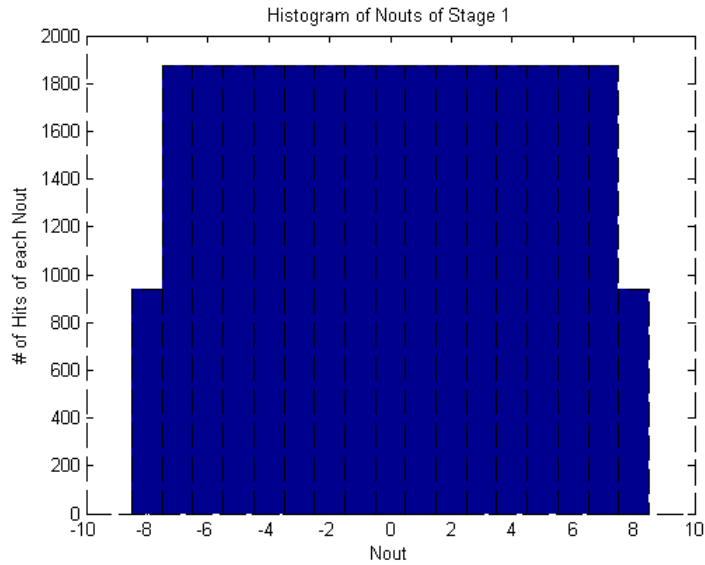

Figure 8: Histogram of Code Levels for a Linear Gain Stage

However, since the codes at the edges of each level begin to deviate away from a general linear relationship in a non-linear gain stage, each code will get hit a relatively

different number of times as the outer code levels will get hit more often. This is shown in the figure below.

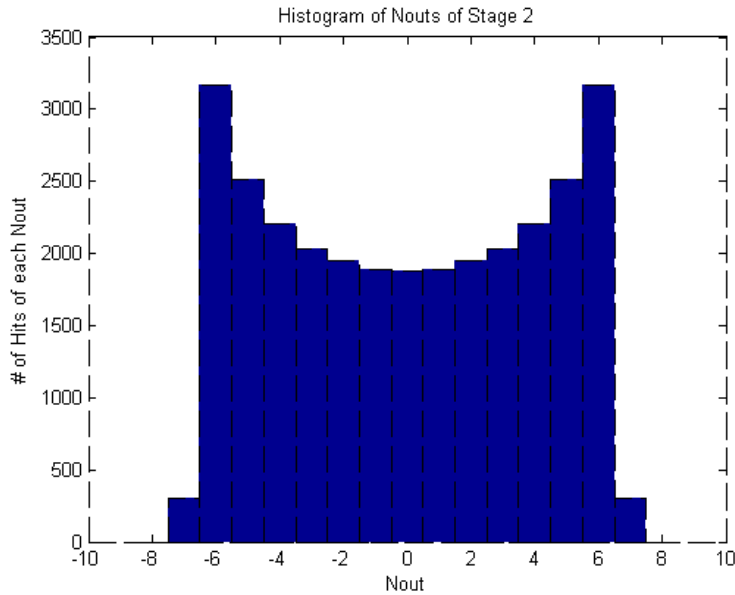

Figure 9: Histogram of Code Levels for a Non-Linear Gain Stage

Finally, we can also see a non-linear relationship between the error of a stage and the input voltage to the pipeline ADC. The figure below illustrates that with a linear gain stage, the error associated with each code level is the same throughout. However, since the codes begin to deviate away from the edges of the 16-levels we see that there is more error associated at the edges of these 16-levels.

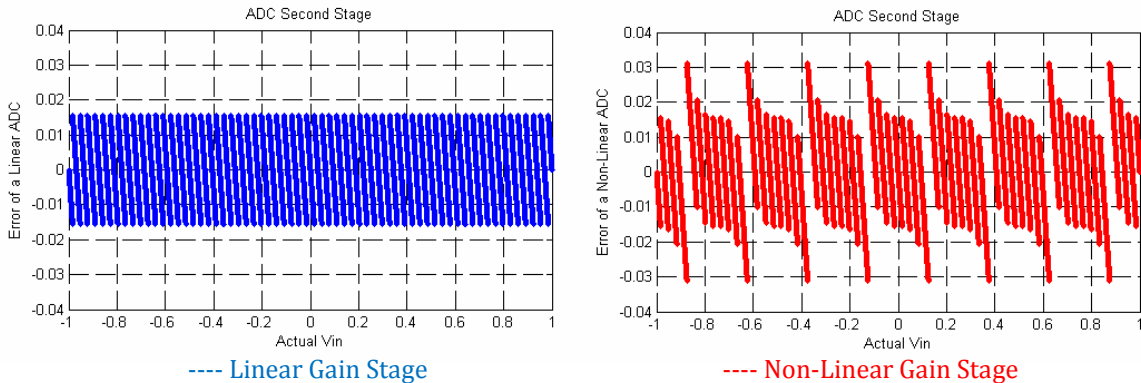

Figure 10: Difference in Error of a Linear and Non-Linear Gain Stage

3.2. Non-Linearity of Simulated ADC

In order to get a better picture of the amount of non-linearity that we will be working with, we simulated a cascode differential pair (see next section) and conducted a DC sweep to measure its output voltage as a function of the input voltage to arrive at a transfer characteristic. Non-linearities are better measured when one looks at the difference between the non-linear gain stage and a linear-best fit line. Any difference between these two will show the amount of non-linearity that exists in the non-linear gain stage, i.e. the cascode differential pair. The figure below shows the simulated data along with the linear best fit line. It also shows the residuals, the difference between these two lines.

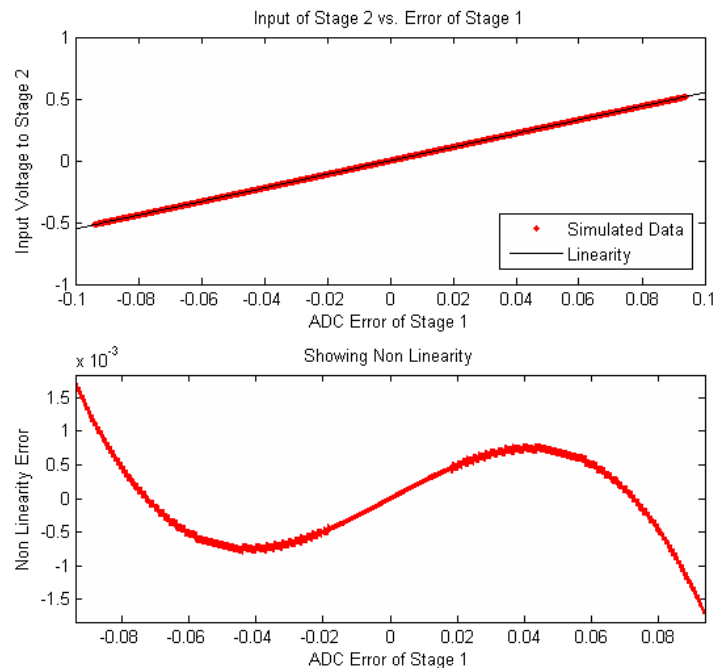

Figure 11: Measuring Non-Linearity in Simulated Data

The figure indicates that there is a maximum non-linearity of approximately 1.5mV in this simulated data.

3.3. Cubic Approximation of Simulated ADC

One method of correcting non-linearity is by using a cubic approximation of the simulated data. The figure below shows this cubic approximation and the amount of error that result from the difference between the simulated data and the approximation.

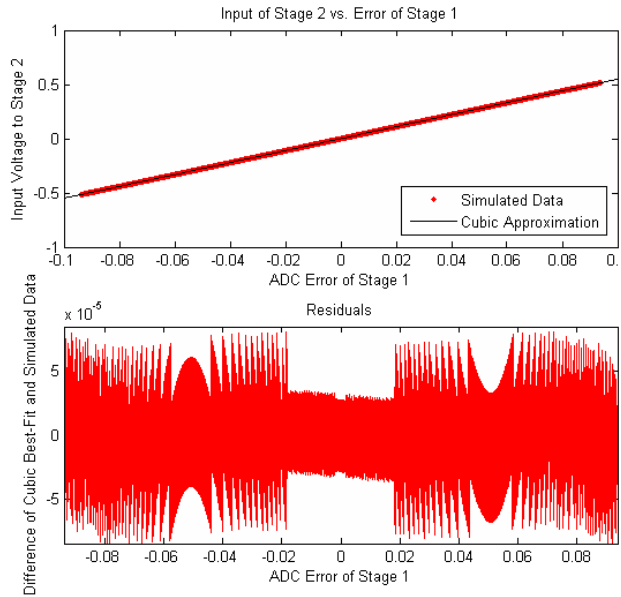

Figure 12: Cubic Approximation of Simulated Data

The max residual is approximately $80\mu\text{V}$. Correcting the non-linearity with a cubic approximation drastically reduces the non-linearity that exists in the simulated data. This is shown in the figure below.

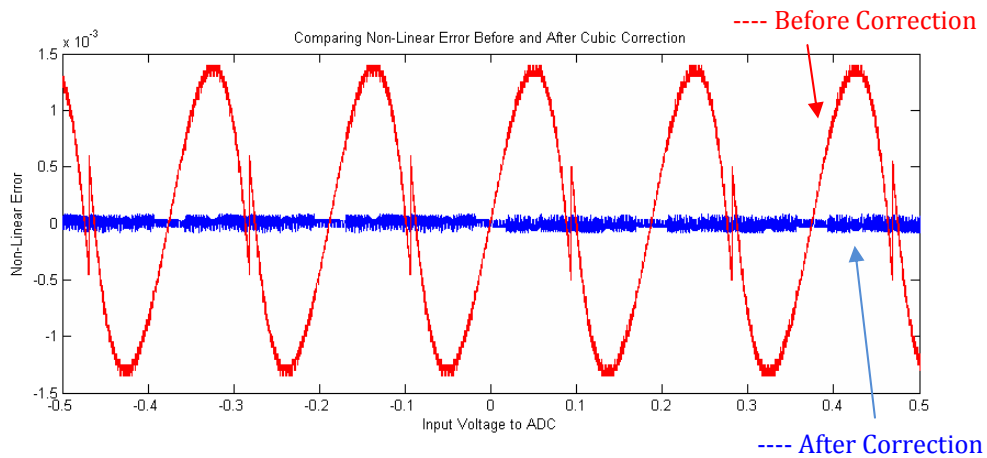

Figure 13: Difference in Non-Linearity Before and After Cubic Approximation

From a maximum non-linearity of 1.5mV, we were able to reduce the non-linearity with a cubic approximation such that the max non-linearity after correction was only 80 μ V.

3.4. Cubic Approximation of Simulated Data from Cadence

Using the simulated data of the Cascode Diff-Pair and the Cascode Diff-Pair with Common Mode Feedback and Replica Bias, a cubic approximation using the MATLAB code was done.

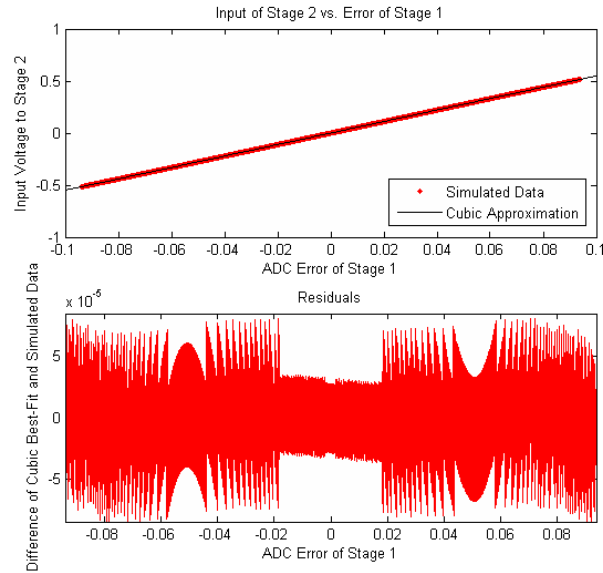

Figure 14: Cascode Diff-Pair without Common Mode Feedback or Replica Bias

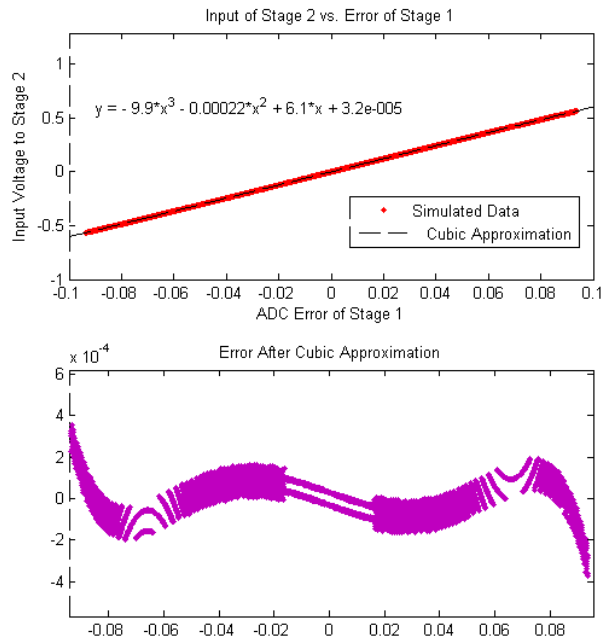

Figure 15: Cascode Diff-Pair with Common Mode Feedback and Replica Bias

The slightly higher error could be potentially due to the increased analog complexity in the latter case. It could be due to insufficient data points used in plotting (Cadence simulation used an input voltage step size of 0.0001V). This issue will be investigated in more detail in due-course. Ideally we would like to see a maximum error of:

$$\frac{3}{2^{16}} = 45.7 \mu V$$

As the maximum error we are currently seeing is higher than this value, we also have an alternate solution that we may use to correct non-linearities: a digital look up table. While a digital look up table does provide more accuracy, it will also increase the digital complexity.

3.5. Digital Look-up Table

As an alternative to the Cubic Approximation method, a digital look up table (DLT) was implemented with some Matlab algorithm (attached in Appendix A). This algorithm uses a known list of Douts (Code outs) to figure out the original V_{in} that caused these codes using an initial guess. The figure below shows the percentage error that was evident from using this procedure for each V_{in} .

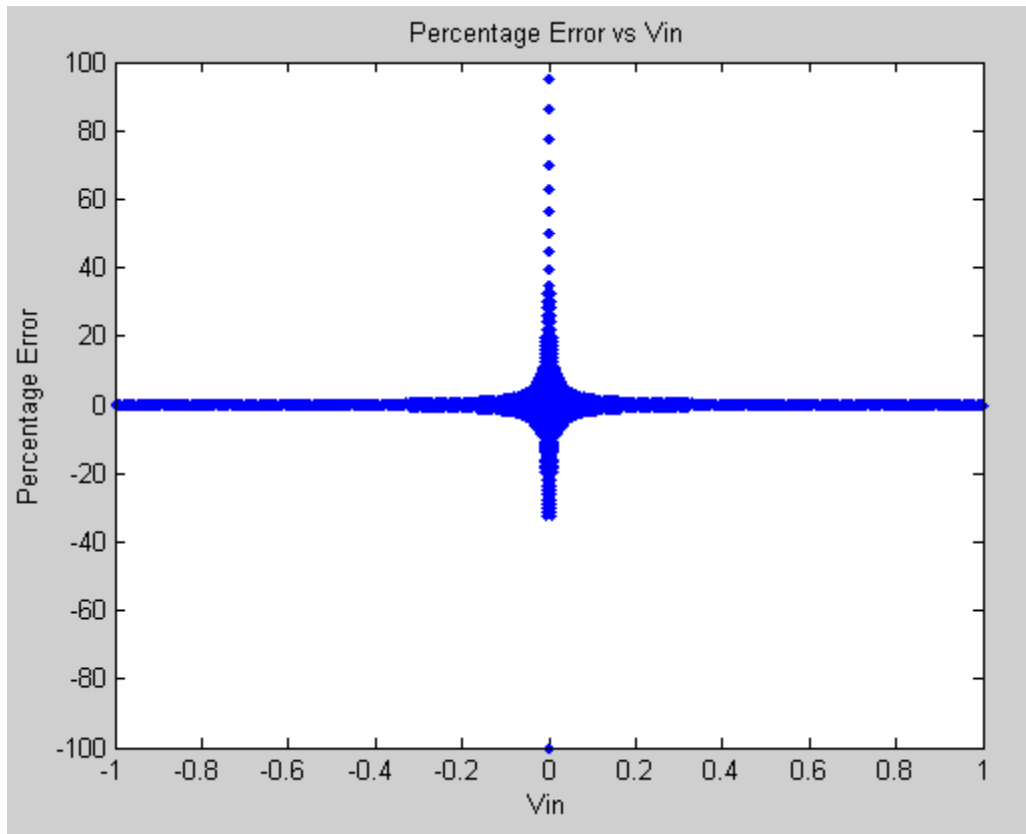

Figure 16: Percentage Error of DLT

These minimal percentage errors show that the DLT is another alternative to the cubic approximation that has been implemented above.

The above conclusion is further evident from the figure below. The Estimated Vin and the Actual Vin have a 1:1 slope.

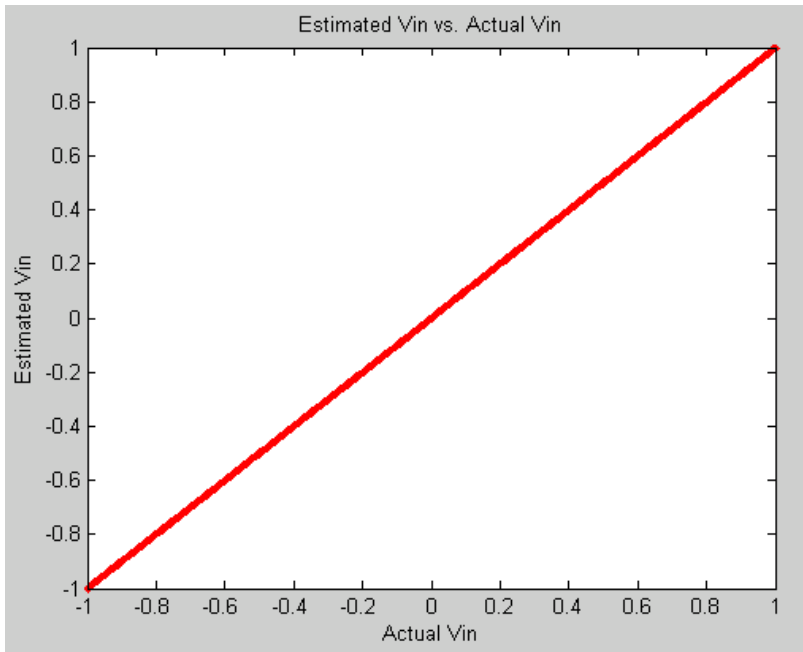

Figure 17: Estimated Vin vs. Actual Vin from DLT

On closer inspection, we do find that there is some error evident from this procedure. The figure below shows the maximum residual to be close to 2mV.

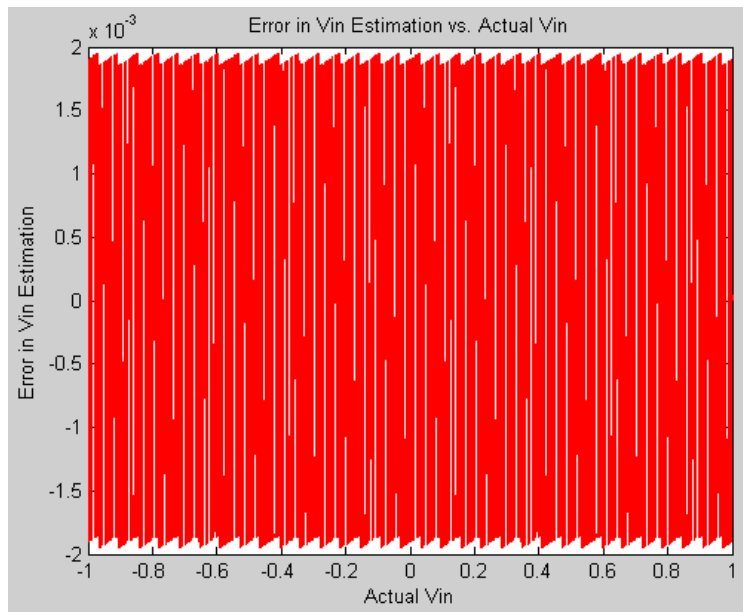

Figure 18: Absolute Error from DLT

This amount is far away from the max residual of $45.7\mu\text{V}$ we were looking to implement. Further analysis and research on the DLT will be needed to verify the feasibility of implementing such a procedure.

4. Circuit-Level Simulation of the Analog Subsystem

The analog subsystem, which includes the Differential Pair, Common Mode Feedback, Replica Bias, and the Switched Capacitor Network were simulated in Cadence. This section explains the design of each of these blocks in detail. The stage1 implementation from [4] is repeated here for convenience:

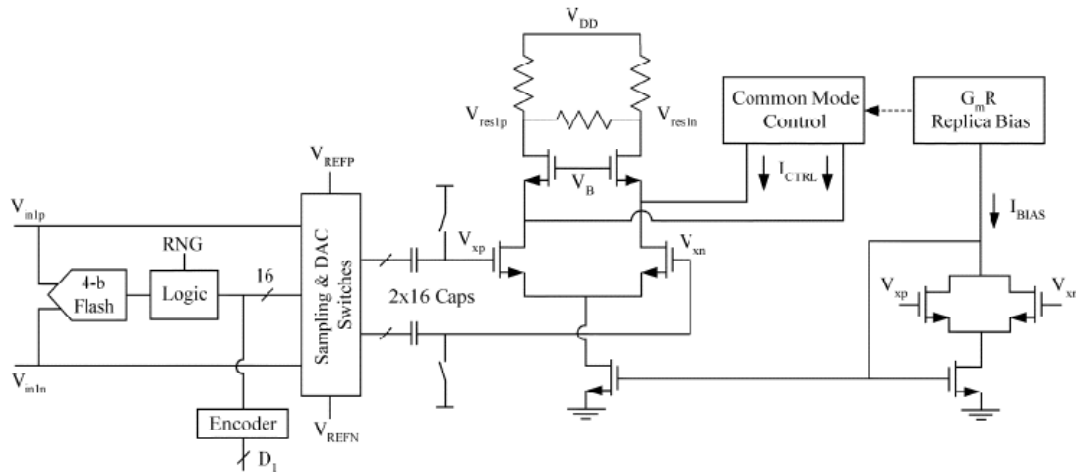

Figure 19: Stage 1 Implementation of Pipeline ADC [4]

4.1. Basic Differential Pair Circuit

The analog subsystem design began with the simulation of a resistively loaded differential pair circuit. As explained in the Prior Work section, a resistive load was preferred to an active load due to deep-submicron compatibility [4]. The low supply voltage (2.5V and Ground) leaves little headroom for a load transistor causing it to easily turn off. A resistively loaded approach means that the high-gain requirement of the differential pair should be relaxed and the non-linearity arising from this stage corrected digitally.

The differential pair circuit specifications were as follows:

- Differential Mode gain = 8
- Input Bias Voltage = 1.25V

- Input Voltage Swing = +/-1.5 V
- Output Bias Voltage = 2 V
- Output Voltage Swing = +/- 0.4 V
- Bias Current = 200uA
- Rail Voltages = 2.5V, Gnd

The gain requirement is not stringent, meaning that proximity of 8 is acceptable. This is again a big advantage in terms of design because a precision amplifier will increase analog complexity where as the present design with its continuous digital background calibration will estimate and remove imprecision errors digitally.

The first simulation was that of a simple differential pair circuit. Please see Appendix A2 for circuit parameters. The simulated diff-pair circuit is shown below:

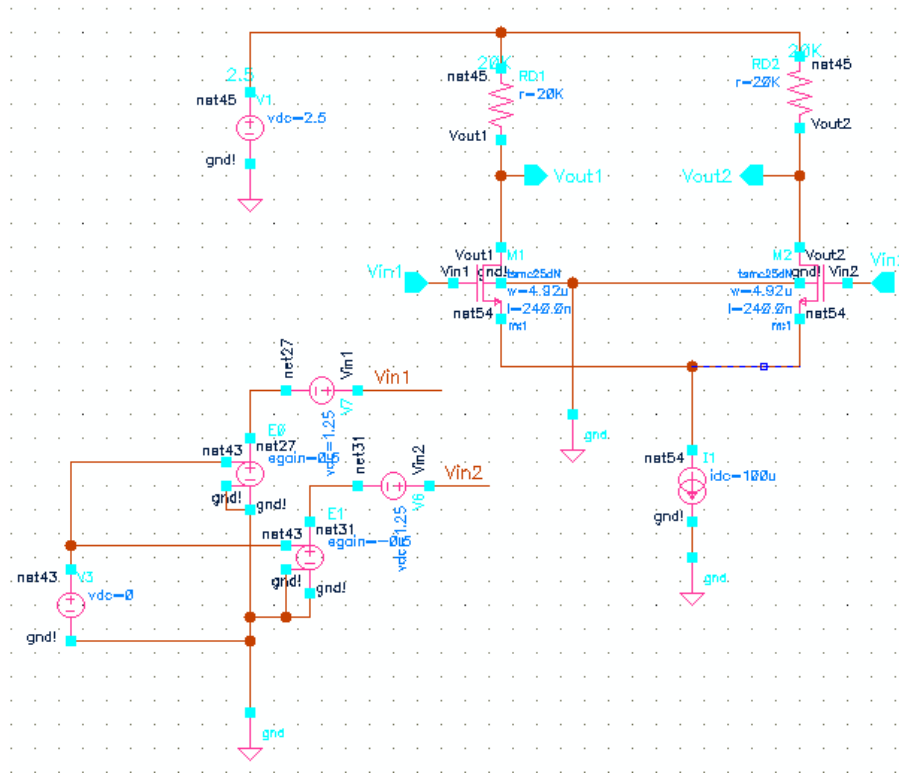

Figure 20: Circuit Schematic of a Simple Diff-Pair

An important design choice was that of a reasonable gate overdrive voltage, V_{OV} , for the input transistors. A higher overdrive voltage increases the linear range of the differential input; although any increase in V_{OV} must be supported by a proportional increase in tail current to maintain constant transconductance:

$$G_m = \frac{I_{bias}}{V_{OV}}$$

Constant transconductance is necessary because the differential pair gain is given by:

$$|\text{Gain}| = |-G_m R_D|$$

where R_D is the load resistor value and the Gain is 8.

To find the optimal V_{OV} , the diff-pair circuit shown above was simulated using 4 overdrive voltages: 150, 200, 250, and 300mV. In addition to comparing the plots of differential output versus input, cubic approximations were fit to each of the 4 cases, to compare the residue (difference between simulated data and fit). The results are shown below:

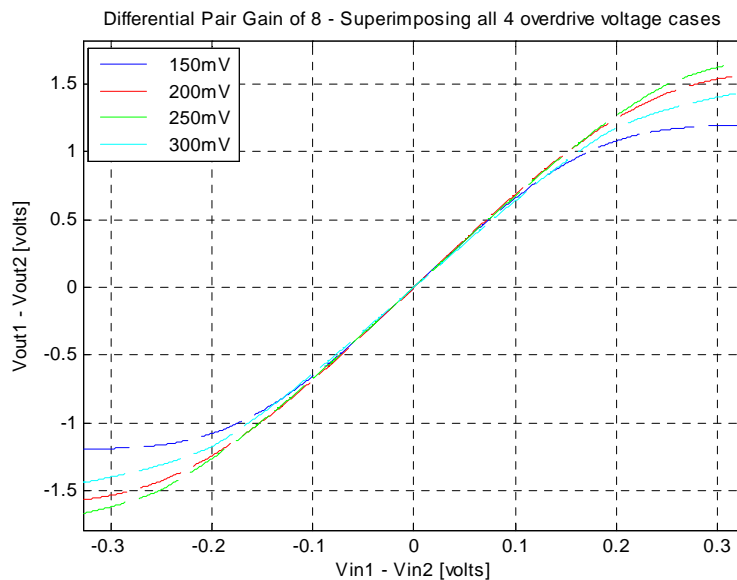

Figure 21: Basic Diff-Pair Output Characteristics for 4 different V_{ov} .

The general pattern that is evident from superimposing all 4 V_{OV} cases is that the linear range of the differential output increases with increasing V_{OV} . The slope near the operating point (i.e. differential gain) in all the cases is approximately 8 as expected because the load resistor values were adjusted in each case to yield a gain of 8. However the output bias voltage will naturally change with varying load resistor values because of the varying voltage drop across the load. It is obvious then that only 1 of 3 diff-pair specifications can be met with a basic diff-pair circuit:

- Differential Mode Gain
- Output Bias Voltage
- Output Voltage Swing

Achieving all 3 specifications would require a more complex design, which is covered in the next section.

In terms of a cubic approximation for the differential output signal, the following plots for differential output and residue were produced (input voltage steps of 0.001 Volts). Since the differential input is fed into a 4-bit Flash ADC (16 levels), and the input signal swing is assumed to be ± 1.5 V, there are $3/16 = 188$ mV in each code level. Therefore the differential input range of ± 94 mV is of primary concern.

The following plots show the differential output and residue versus differential input for all 4 V_{OV} cases.

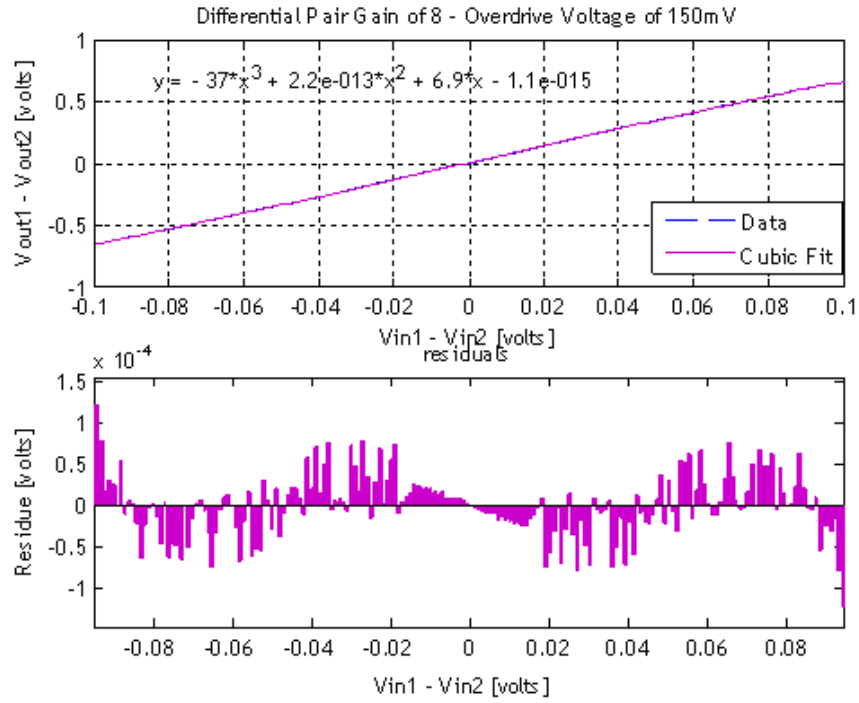

Figure 22: Residue Plot for an Overdrive Voltage of 150mV

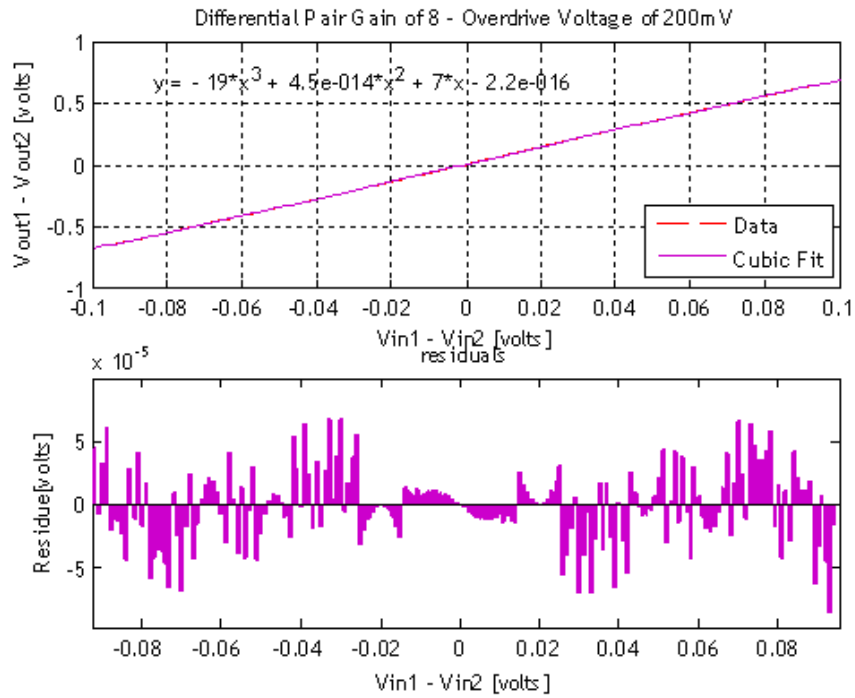

Figure 23: Residue Plot for an Overdrive Voltage of 200mV

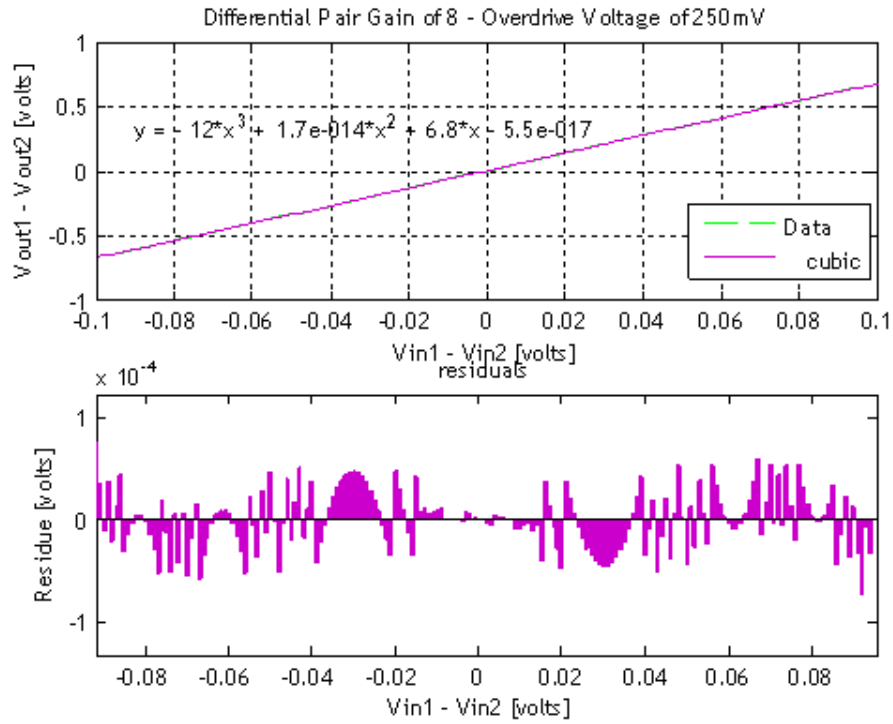

Figure 24: Residue Plot for an Overdrive Voltage of 250mV

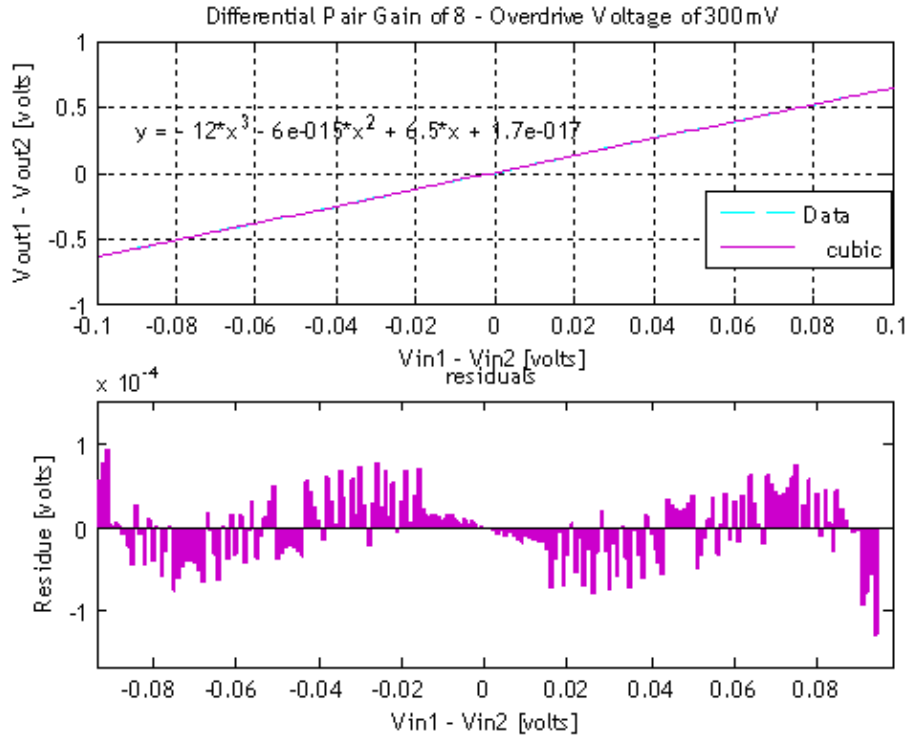

Figure 25: Residue Plot for an Overdrive Voltage of 300mV

After comparing the Max of Residues in each case, the smallest residue occurs with an overdrive voltage of 250mV. This implies that an overdrive voltage of 250mV is the ideal choice, and digital correction of this non-linearity will further decrease the Max Residue.

Table 2: Overdrive Voltage Residue Results Summary

Overdrive Voltage	 Max of Residue [μV]
150 mV	125
200 mV	90
<i>250 mV</i>	<i>70</i>
300 mV	140

As mentioned earlier in the section, the need to simultaneously meet the differential gain, output bias voltage and output voltage swing specifications requires the use of an alternative design. In addition, a design that lowers the Max Residue for the 300mV OV case is investigated in the next section.

4.2. Cascode Diff-Pair with Pi-Resistor Network

As shown in the previous section, a design that controls differential gain, output bias voltage and output swing independent of each other is desired. In addition, a design that decreases the Max Residue for an overdrive voltage of 300mV below that of the 250 mV case would be useful.

The Basic Diff-Pair output versus input plot is repeated here for convenience:

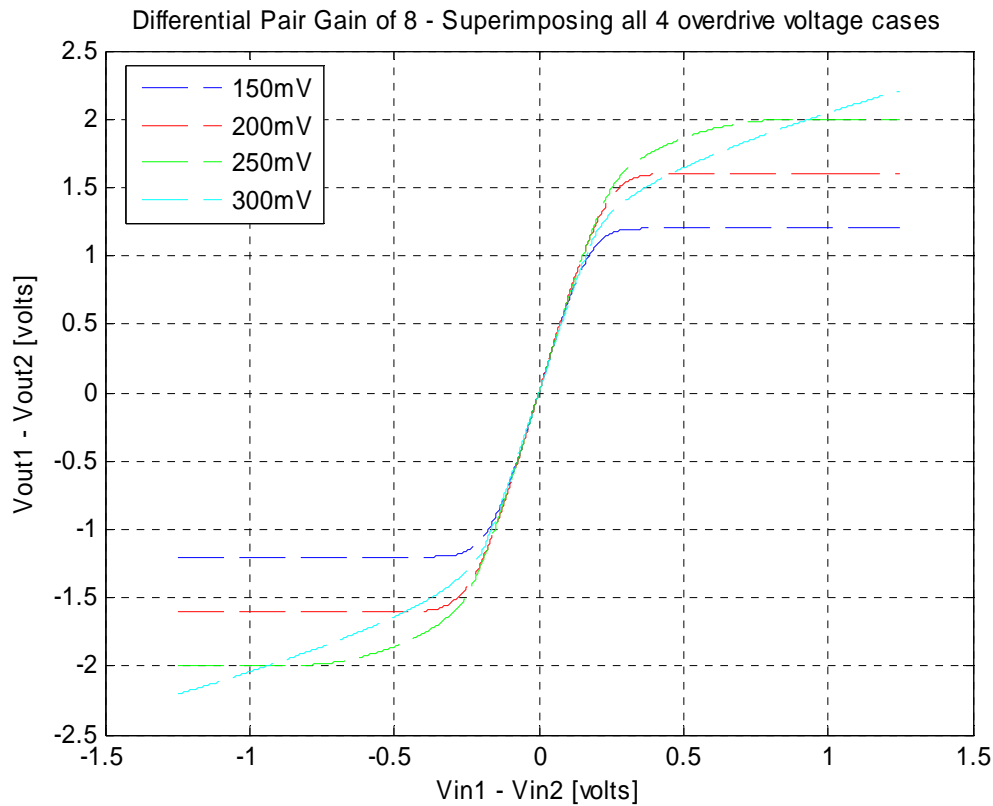

Figure 26: Basic Diff-Pair Output versus Input for Various Overdrive Voltages

It is obvious that the 300mV curve has a different shape than the other three in the differential input range of ± 1 V. A possible explanation was that changes in the diff-pair output voltage causes the MOSFET V_{DS} to vary, and therefore at overdrive voltages greater than 250mV the transistor crashes into the triode region.

To verify this hypothesis, a cascode gain stage was added to the diff-pair. A cascode has two main properties:

1. High Output Impedance, resulting in high gain, and
2. Limiting the voltage across the input transistor

To illustrate the first property, a simple common source amplifier is simulated with and without a cascode. As shown below, the non-cascode curve has a positive slope in the active region, whereas the cascode has an almost zero slope. Since the output impedance is given by the inverse of the slope, it is obvious that the cascode has produced very high (ideally infinite) output impedance by removing the Gate-Drain Capacitance (Miller Effect).

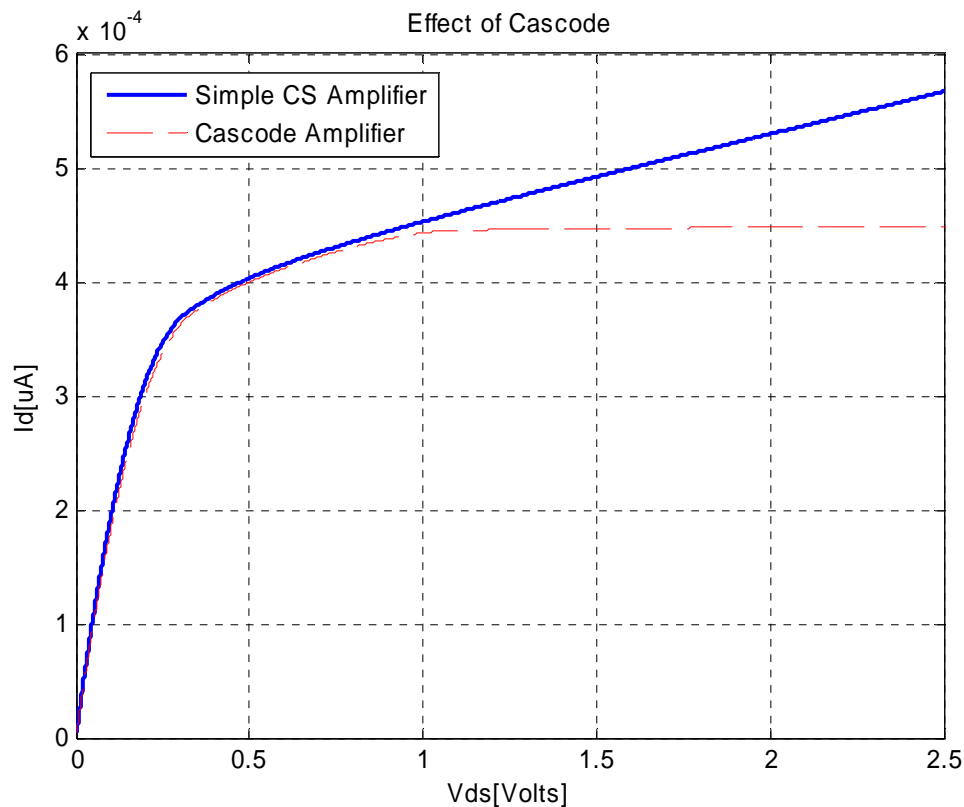

Figure 27: Illustration of Cascode High Output Impedance

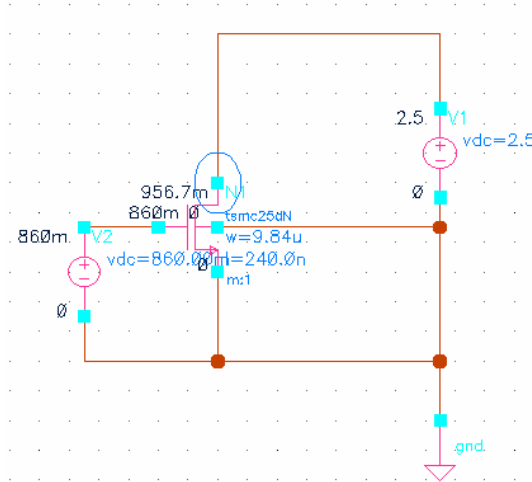

Figure 28: Simple Common Source Circuit

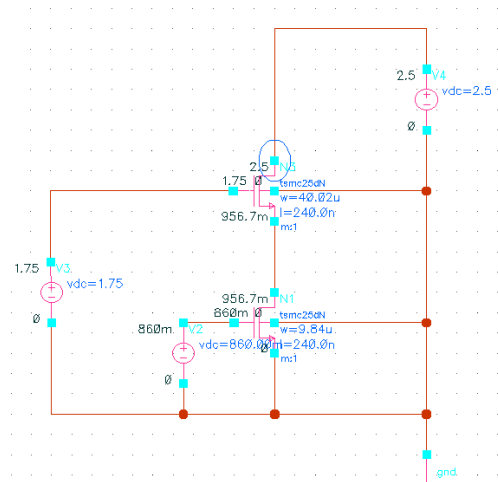

Figure 29: Cascoded Common Source Circuit

The cascode was therefore implemented in the diff-pair design to see if the issue with the 300mV curve is resolved. This configuration is referred to as a telescopic-cascode.

The figures below show a comparison of a cascode diff-pair with a non-cascode diff-pair in terms of differential output versus input characteristic, and differential gain.

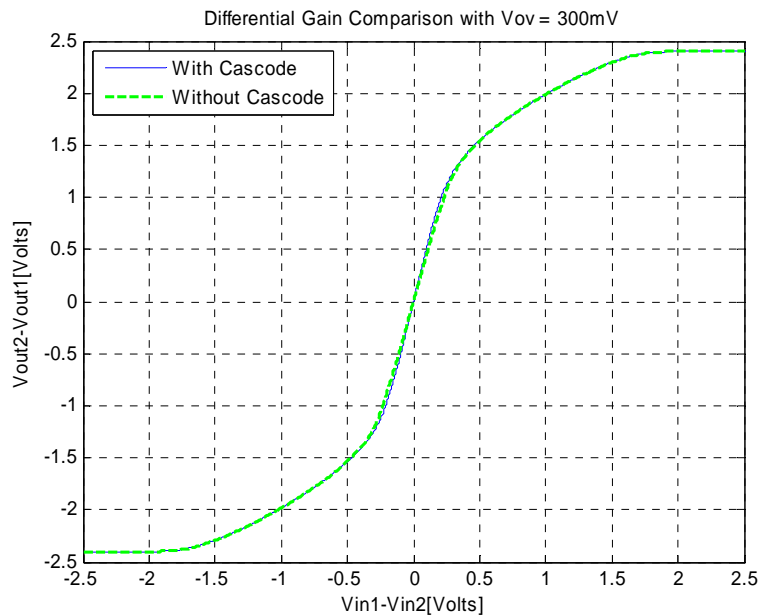

Figure 30: Comparison of Cascode and Non-Cascode Diff-Pair Output Characteristics

Clearly, the addition of a cascode did very little to improve the shape of the curve. However, the small-signal gain at the operating point did increase from 4.5 V/V to about 5.3 V/V. This graph is obtained by taking the first-derivative of the above curve.

In this simulation, the RD is set to 24K, and $W = 1.23\mu\text{m}$.

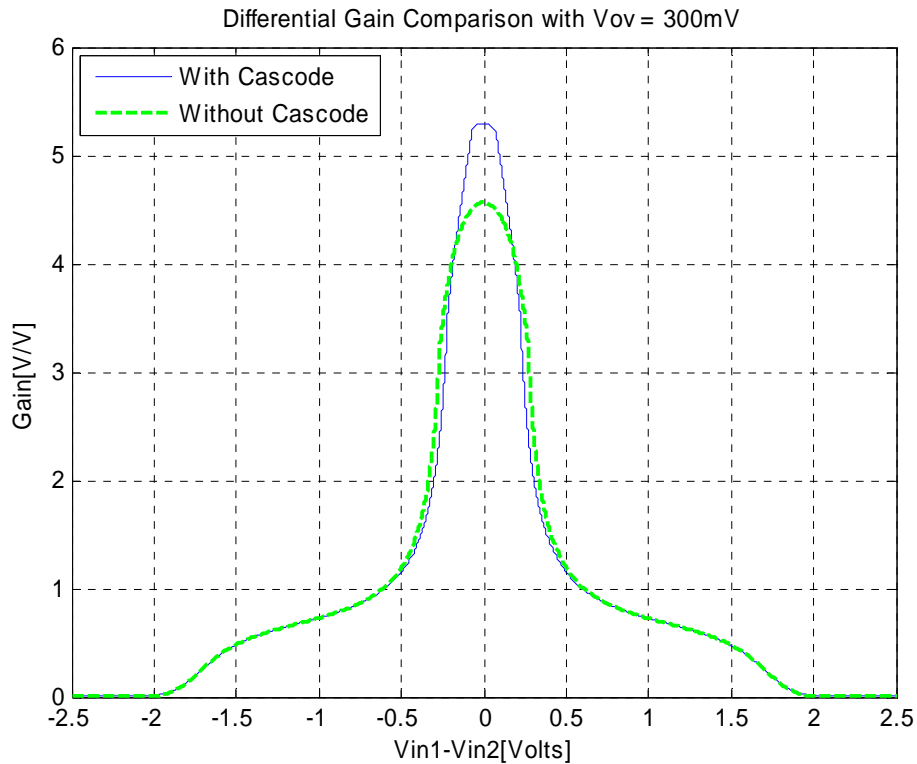

Figure 31: Small Signal Gain Comparison of Cascode and Non-Cascode Diff-Pair

One possible explanation for this behavior is that in the small signal model, the high output impedance of the cascode stage is placed in parallel with the resistive load of the diff-pair. Therefore the maximum effective output resistance of the diff pair is dominated by the resistive load. By increasing the resistive load, however, will lead to a lower output bias voltage, and will cause the input MOSFETS to crash into triode.

To overcome this issue of gain versus output bias, a Pi-Resistor configuration is used, which is basically a resistor that connects both the outputs. This extra resistor, R_G ,

reduces the gain because in differential mode $R_G/2$ is placed in parallel with the load resistor, R_B . Nevertheless in common mode R_G is Open, and only R_B controls the output bias voltage. As a result R_B is picked to be a large enough resistor, i.e.

$$R_B \parallel R_G/2 > R_D$$

where R_D is Gain/Transconductance. R_G , which is used to knock down the gain to a desired level, is then picked accordingly to satisfy the above equation.

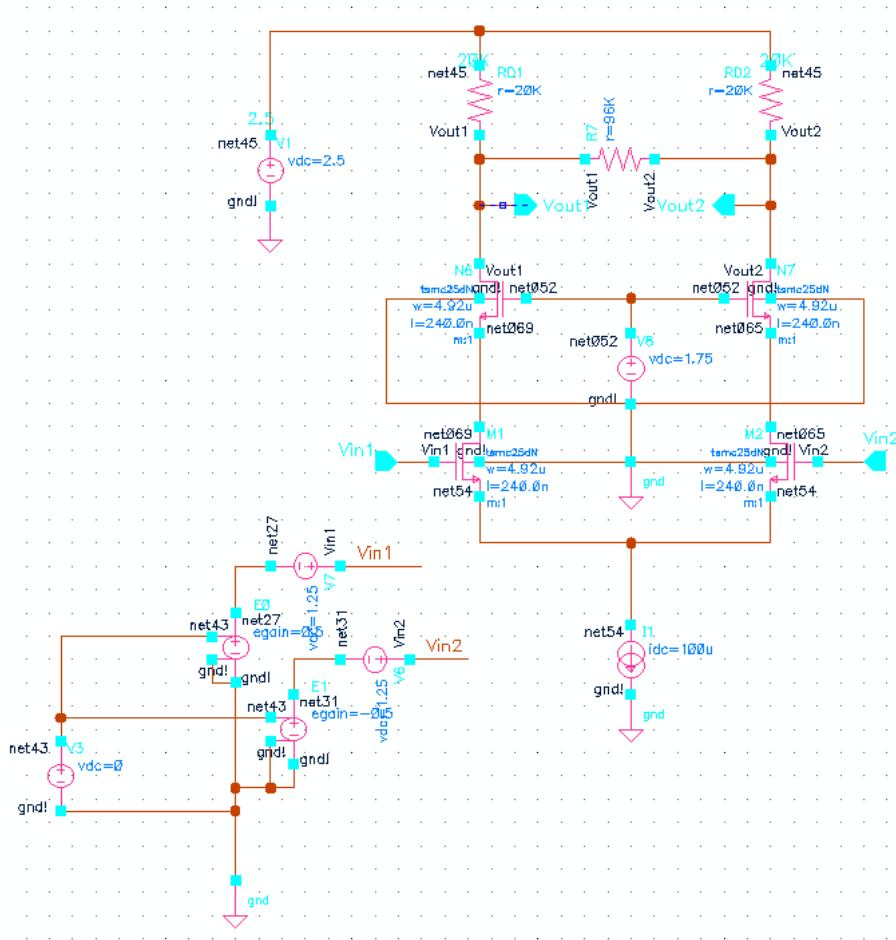

Figure 32: Cascode Diff-Pair with Pi-Resistor Network

Table 3: Summary of Cascode Diff-Pair Parameters

V_{ov} [mV]	W [μm] for M1, M2	W [μm] for N6, N7	Load Resistance [$\text{K}\Omega$]	R7 [K Ohms]	Gm [$\mu\text{A/V}$]
150	4.91	4.91	12	96	$6.666 * 10^{-3}$
200	2.76	4.91	16	120	$5 * 10^{-3}$
250	1.77	4.91	20	100000	$4 * 10^{-3}$

The differential output versus input for the above circuit is shown below, along with residue plot for the 250mV case.

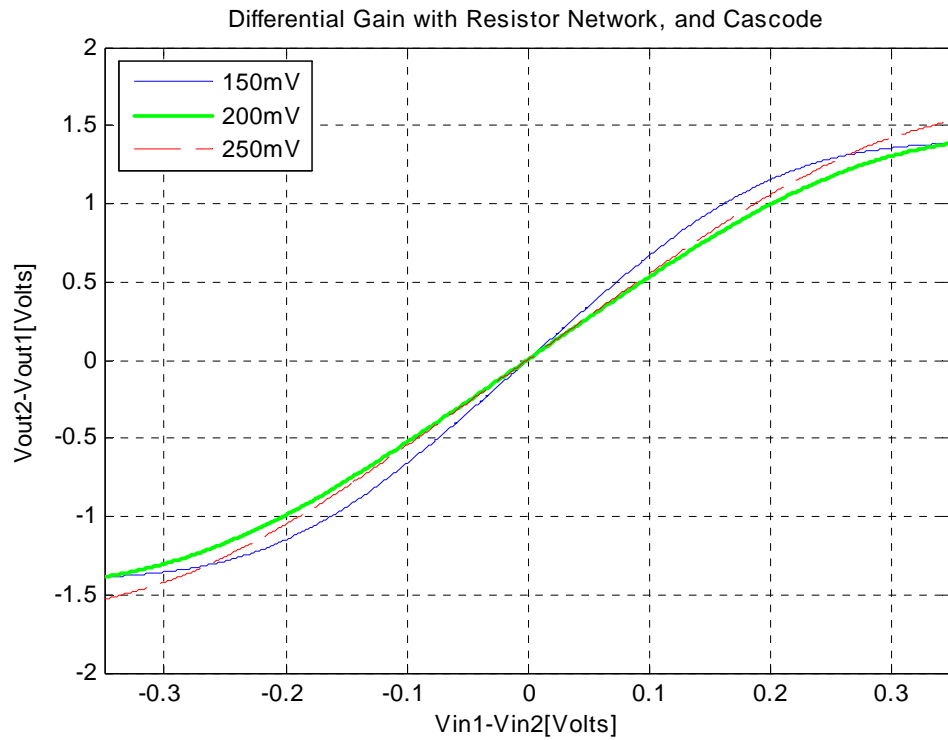

Figure 33: Cascoded Diff-Pair Differential Output versus Input characteristic

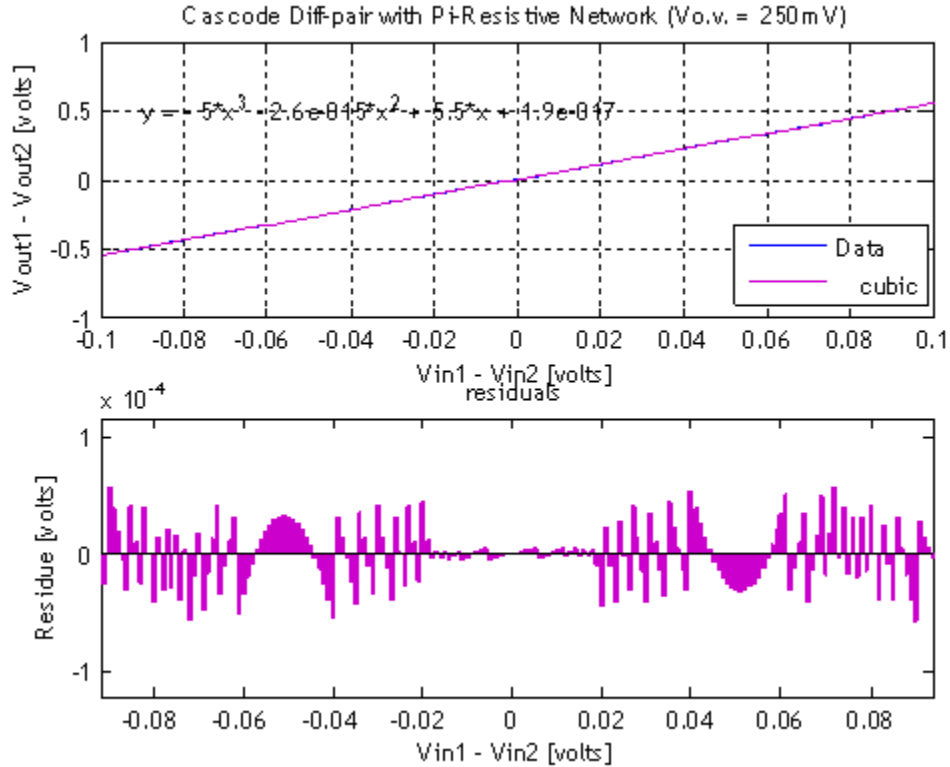

Figure 34: Cascode Diff-Pair Residue Plot

A quick comparison of the first plot with that of the non-cascode diff-pair shows that both the differential gain and output bias voltage specifications can be met using this design. The second plot shows that the use of a cascode did very little, if any, to improve the Maximum Residue Voltage. These two results are as expected because the resistor network allows the independent control of both output bias voltage and the gain, and the cascode is meant to increase output impedance.

In any case, the differential voltage swing specification is still not met because it depends on the current through each input transistor and the load resistance, both of which are fixed in this design:

$$\text{Voltage swing} = 0.4 = I_D * R_D$$

Choosing R_D from the above equation is not an option since the gain has to be fixed at 8:

$$\begin{aligned}R_D &= \text{Gain} / G_m \\ &= 8 / 800\mu\text{A/V} \\ &= 10\text{K}\Omega.\end{aligned}$$

($G_m = 2 * I_D / V_{OV}$, where $I_D = I_{BIAS} / 2 = 100\mu\text{A}$ and $V_{OV} = 0.25\text{V}$)

Changing I_D would change the transconductance of the input transistors that will once again affect the diff-pair gain:

$$G_m = \sqrt{2I_D \mu_n C_{ox} \left(\frac{W}{L}\right)}$$

In addition, an increase in I_D will increase the voltage drop across the load resistors, and will bring down the output bias voltage causing the MOSFETs to crash. Therefore, I_D needed to be changed in a way that satisfies the Voltage Swing condition but keeps the output bias at 2V and the input MOSFET transconductance at 800 $\mu\text{A/V}$.

The ‘‘Split Current’’ approach solves this issue by only providing a fraction of the bias current through the load resistor. The current then through each load resistor is

$\left(\frac{1}{2} - x\right) * I_{BIAS}$ where x is chosen such that the output bias voltage spec is satisfied. The

remaining current is provided directly to the drain of the input MOSFET when the common mode control is implemented. This satisfies the input MOSFET

transconductance specification. The parameters and values chosen for the Cascoded Diff-Pair are detailed in Appendix A3.

4.3. Common Mode Feedback & Replica Bias

Due to the enhanced output resistance, the output biasing point is unstable and highly sensitive to supply voltage variations and complementary device mismatches. It results in dc biasing deviation and unwanted ac coupling [5]. To overcome this drawback, common-mode feedback is used for bias stabilization and a Replica-Tail Feedback technique to keep the tail current constant despite variations in the input common mode voltage level [6].

The Common Mode Feedback (CMFB) works by sensing the output common mode voltage, V_{OCM} , and comparing it to a reference voltage of 2V. When $V_{OCM} = 2V$, the default 60 μ A is sent to the drain of the input transistor (refer to Appendix A3 for explanation of this 60 μ A). If V_{OCM} increases, the CMFB current is reduced accordingly to bring V_{OCM} back to 2V. Similarly, a decrease in V_{OCM} will cause the CMFB to pump additional current to bring V_{OCM} back to 2V. This circuit works in a negative feedback loop, pumping additional or less current depending on the common mode voltage.

As shown in the circuit on the next page, an actively loaded diff-pair senses the common mode output. The output of this sensing circuit is connected to 2 PMOS transistors which route the current back to the cascoded diff-pair in a feedback loop.

The Replica Bias technique is needed to reduce overall sensitivity to ambient temperature changes. As temperature increases, the load resistance increases, causing the gain to increase unpredictably. To minimize this possibility, the replica bias circuit adjusts the bias current as necessary by sensing the input and output voltages. The replica bias transistors are scaled down by a factor of 8 compared to the input MOSFETs to

reduce power consumption. Appendix A3 lists all the circuit parameters of the figure below.

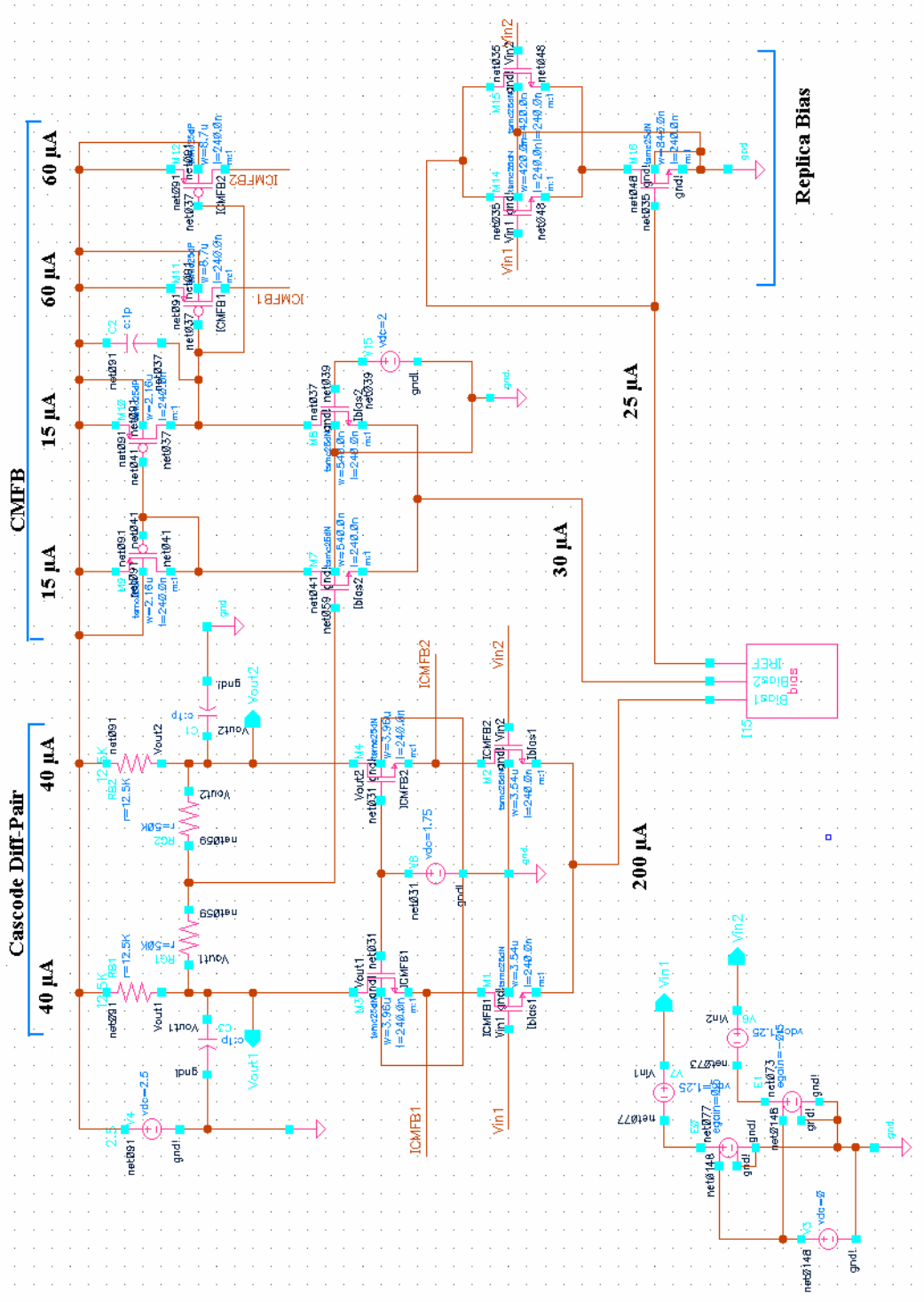

Figure 35: Circuit Schematic of Cascoded Diff-Pair with CMFB and Replica Bias

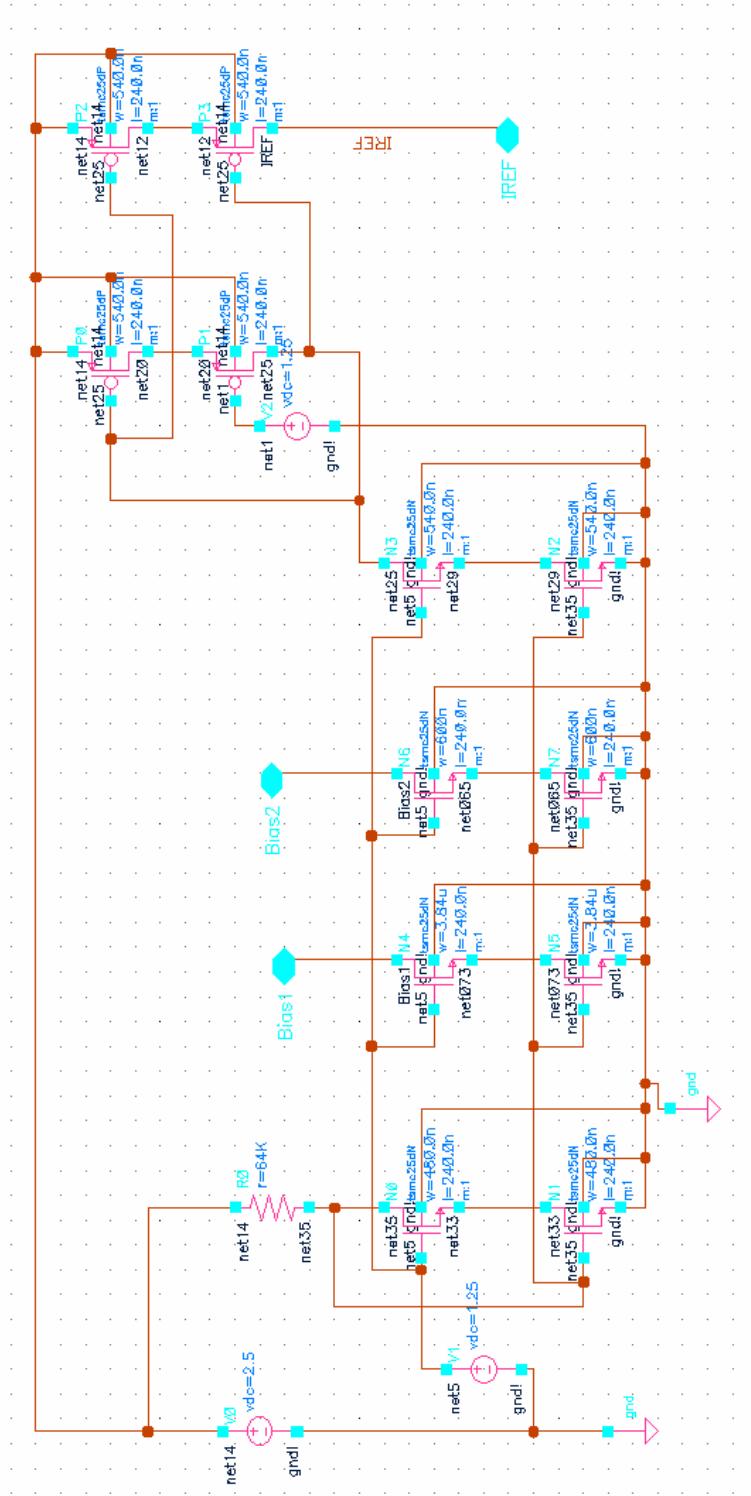

Figure 36: Bias Circuit for Diff-Pair and CMFB

The voltage output versus differential input plot is shown below. As expected, the output bias voltage is fixed at 2V, the output swing is +/- 0.4V, and the actual gain is approximately 6.1.

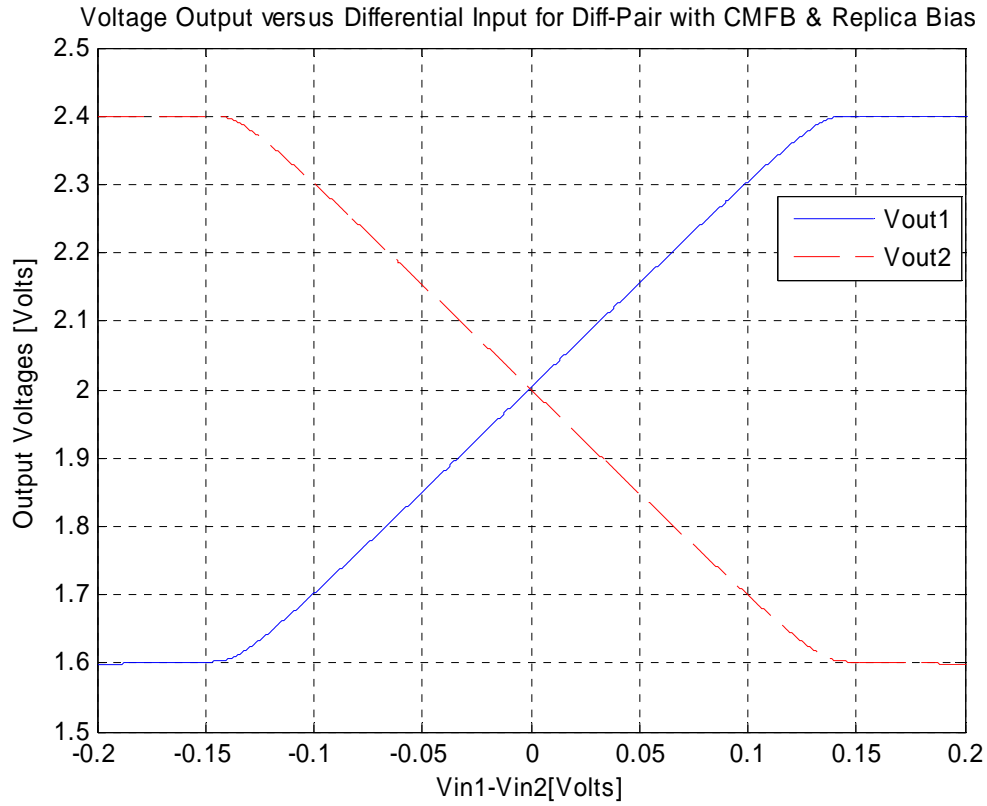

Figure 37: Output vs. Input for Cascode Diff-Pair with CMFB and Replica Bias

Since the +/- 94 mV range is of primary concern, the differential output versus differential input plot on the next page shows the behavior in that range.

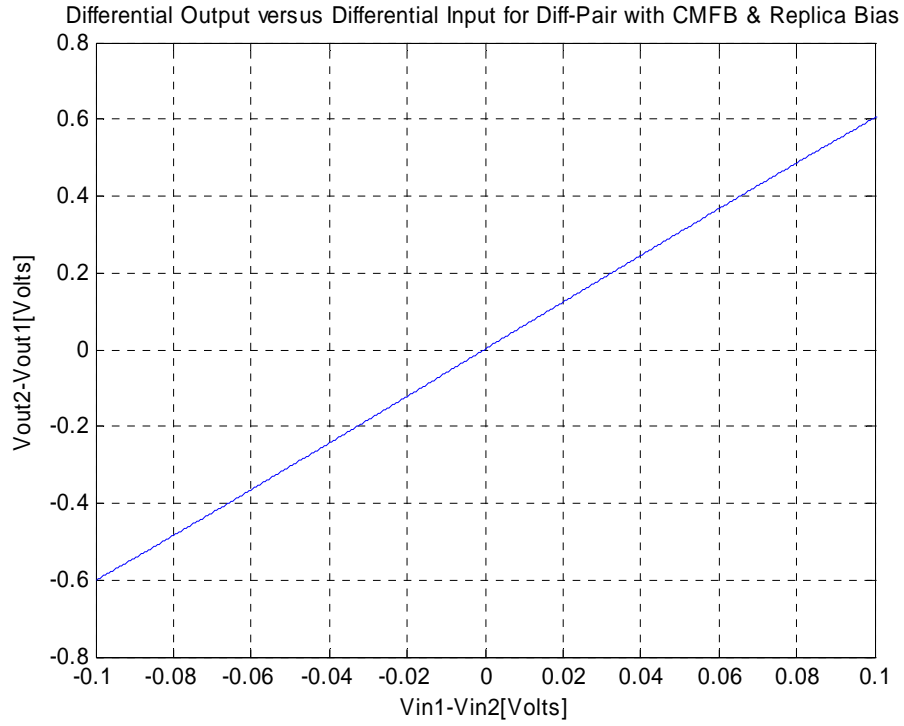

Figure 38: Differential Output versus Differential Input for Cascode Diff-Pair with CMFB

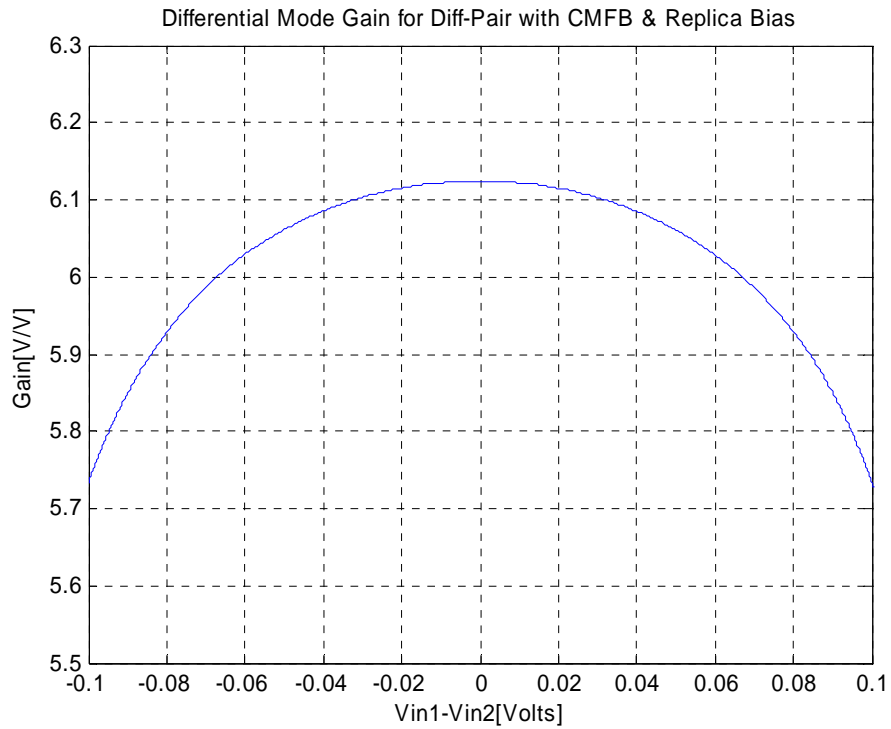

Figure 39: Operating point gain for a Cascode Diff-Pair with CMFB & Replica Bias

4.4. Diff-Pair Settling time

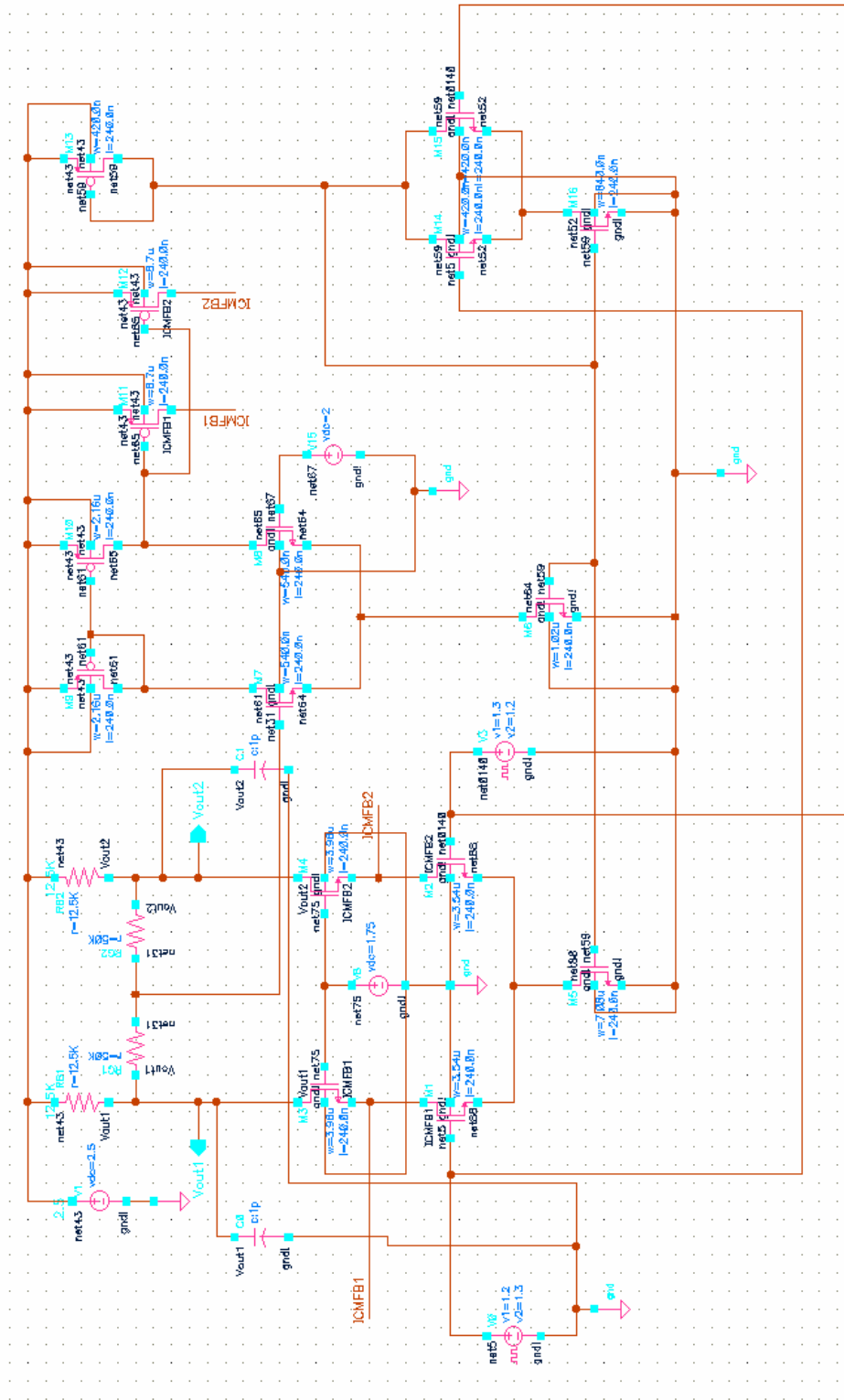

Figure 40: Test Circuit for Measuring Settling Time of Diff-Pair

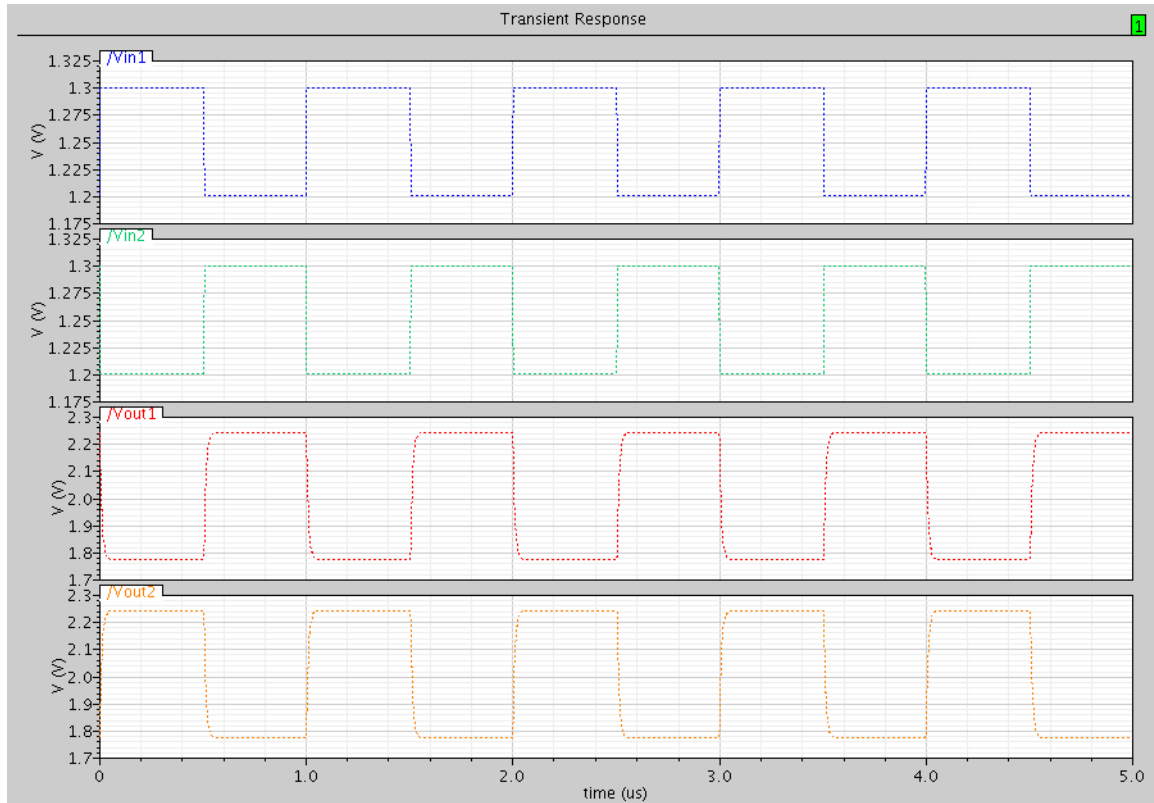

Figure 41: Setting Time Performance Input and Output Voltage

The input voltages are 2 square waves with 1us period and a 1.2V – 1.3V pk-pk. Vin1 has a +500mV AC signal riding on a 1.25DC bias and Vin2 has a -500mV AC signal riding on the same bias voltage. The maximum and minimum output voltages can be predicted by grounding one input terminal of the diff-pair and forcing all the current to flow through the other half of the diff-pair. This resulted in a maximum Vout of 2.241348V, and a minimum Vout of 1.771552V.

For a 14-bit ADC, the first 11bits are of high importance to us, and therefore settling time is measured primarily for those 11bits. Therefore, $(0.8)/(2^{11}) = 390\mu\text{V}$. As a result the settling performance is characterized by the time it takes for the amplifier to settle within +/- 390 μV of the maximum and minimum output voltages. This means $2.241348\text{V} - 390\mu\text{V} = 2.240958\text{V}$, and $1.771162 + 390\mu\text{V} = 1.771552\text{V}$ are the voltage

levels at which the settling time should be measured. Doing so results in a rise-time of 64ns and a fall-time of 62.35ns.

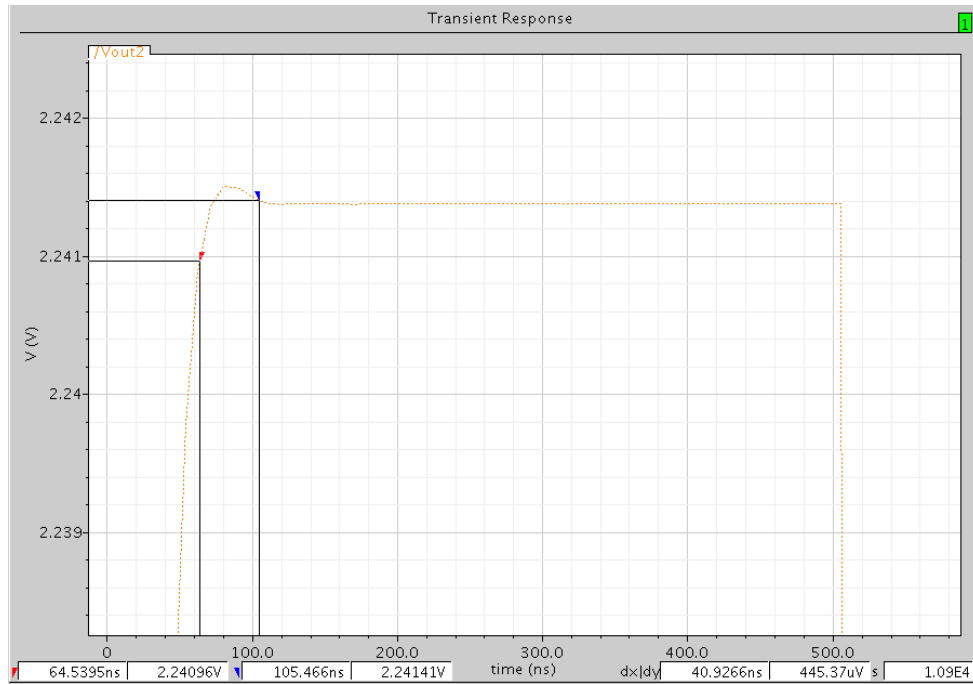

Figure 42: Rise-Time Measurement

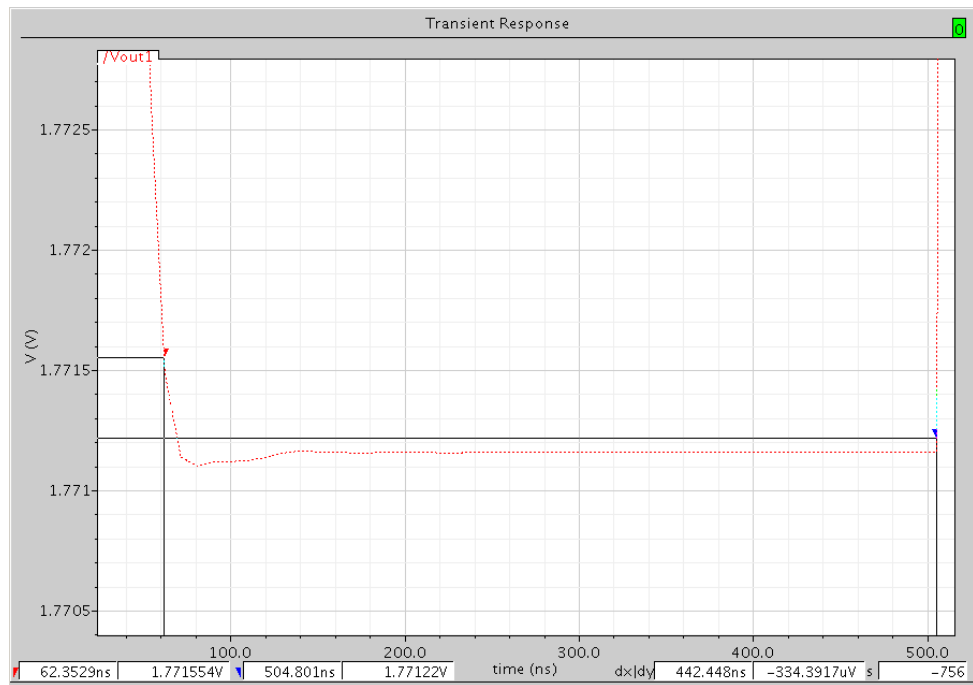

Figure 43: Fall-Time Measurement

The step size was $1 \cdot 10^{-12}$ and the max step was $1 \cdot 10^{-8}$

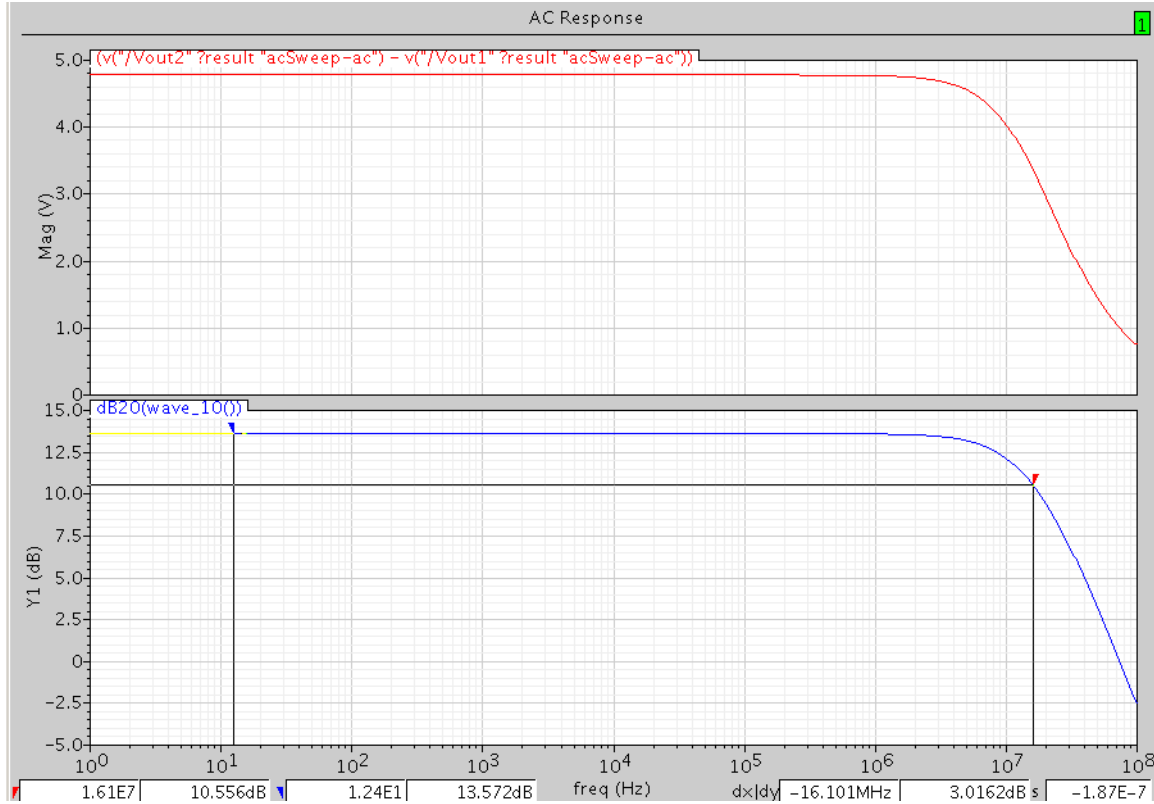

Figure 44: AC Simulation of Differential Pair

The AC simulation of the Differential pair with 1pF load capacitors across the outputs, and another 1pF capacitor between the Gm stage and the CMFB. The 3dB frequency bandwidth = 16.1 MHz, which is comparable to the value obtained through the DC simulations (11 MHz). :

4.5. Switched Capacitor Network

Switched-capacitor networks have become very popular due to their accurate frequency response as well as good linearity and dynamic range. Filter coefficients of a switched capacitor network can be easily obtained as they are determined by capacitance ratios which can be set very precisely on an integrated circuit (with an order of 0.1 percent error). By modifying the capacitance ratios, we can change the settling time and also the frequency response of the entire network. Moreover, a switched-capacitor network takes up a dramatically less amount of die-area as compared to a simple RC integrator, which may serve the same purpose. A smaller amount of die-area also results in a lower cost as size is very costly in IC manufacturing industry.

The schematic of our initial block is shown below. This circuit has two main phases. In phase 1 (P1), the capacitor is sampling the input voltage relative to 1.25V. In phase 2 (P2), the potential to the left and to the right of capacitor adjust to correct for the DAC voltage levels. Although complicated, this process occurs systematically. At any given time, either P1 or P2 signals are turned high but never at the same time. If they happen to be turned on at the same time, then charges get lost and are transferred from one MOSFET to another incorrectly and hence the correct voltage cannot be sampled.

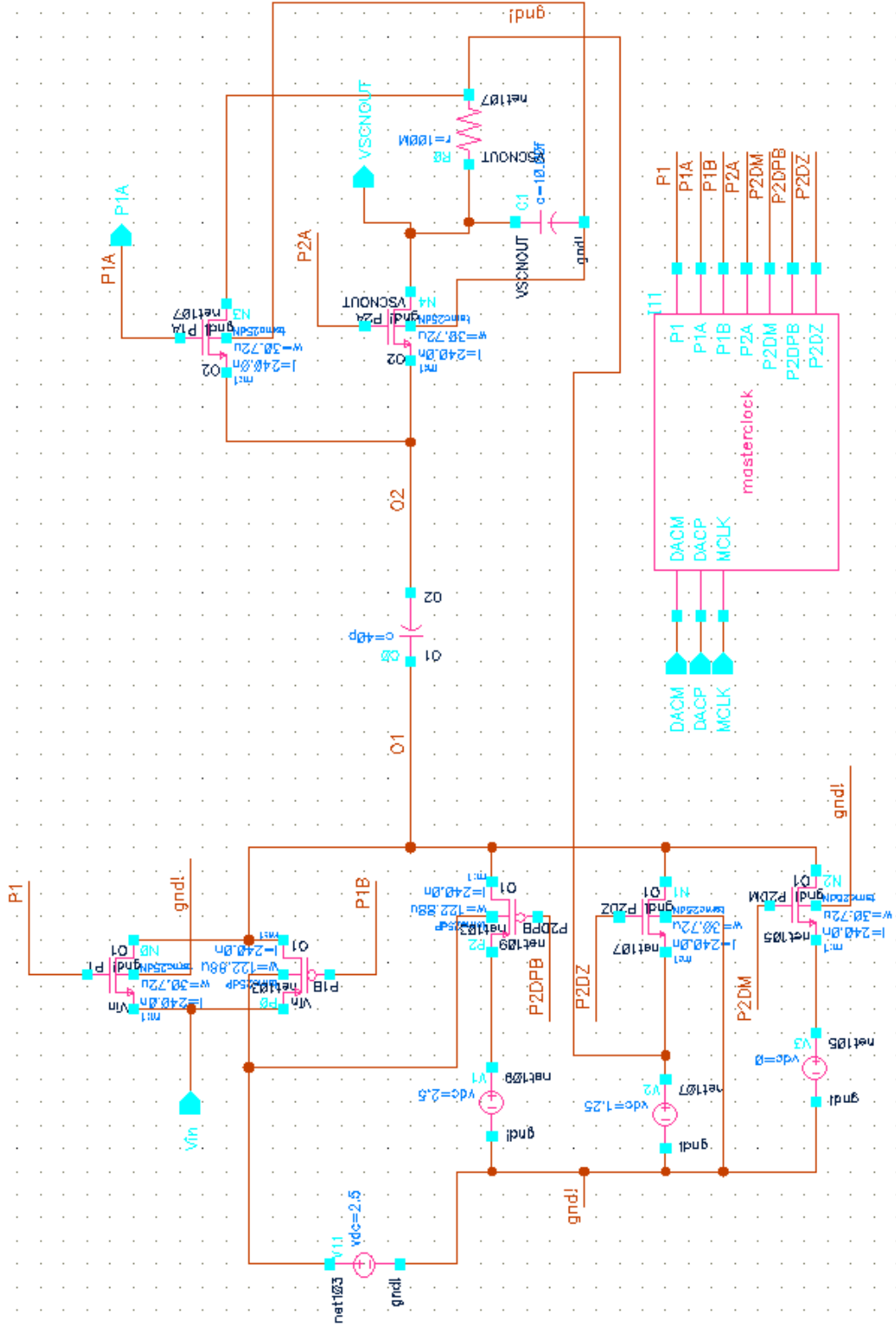

Figure 45: Switched-Capacitor Network Schematic

When P1 is high, the potential to the right of the capacitor, O2, is set to a constant 1.25V. The potential to the left of the capacitor, O1, is set to the input voltage of the Sample and Hold Circuit. This separation of charge between the capacitor plates charges up the capacitor, and hence the capacitor samples the input voltage relative to the 1.25V being supplied. When the capacitor has charged up to the correct voltage, then P1 turns off and P2 turns on. At Phase 2, the voltage at the capacitor switches to the correct DAC voltage level (0V, 1.25V or 2.5V) as determined by the DAC. There are two signals from the DAC that indicate whether a signal is closer to a low, mid or high voltage. The truth table of this is shown below.

Table 4: Truth Table for DAC Signals

DACP	DACM	On Signal	Level
1	0	P2DPB	High
0	0	P2DZ	Mid
0	1	P2DM	Low

When P2 is on and the DAC signals that a high voltage was detected for the input voltage, then signal P2DPB turns off turning on the PMOS that it is connected to. Turning on this MOSFET drives the voltage at the capacitor to the 2.5V rail. On the other hand, if the DAC signals had indicated a mid voltage level, the P2DZ would have turned on, and hence turned on the NMOS that it is connected to. Turning on this NMOS drives the voltage at the capacitor to the 1.25V rail. Similarly if the DAC had signaled a low voltage signal, then it would have turned on P2DM and hence turned on the NMOS device that it is connected to. This would drive the voltage at the capacitor to the 0V rail. In any of these three situations, the voltage difference between the sampling stage and the DAC correction stage at O1 is reflected at O2 as well, as the capacitor tries to maintain the same charge between its plates. Hence if V_{in} was 1.2V, and the DAC signaled this

voltage to be a midlevel voltage, then during the DAC correction stage, the voltage at the capacitor would drive up to 1.25V. This change of 0.05V at O1 is shown at O2 as well and hence drive the output voltage at O2 from 1.25V to 1.30V, keeping the charge of the capacitor constant.

The signals for the master clock were designed using the logic shown in the schematic shown on the next page.

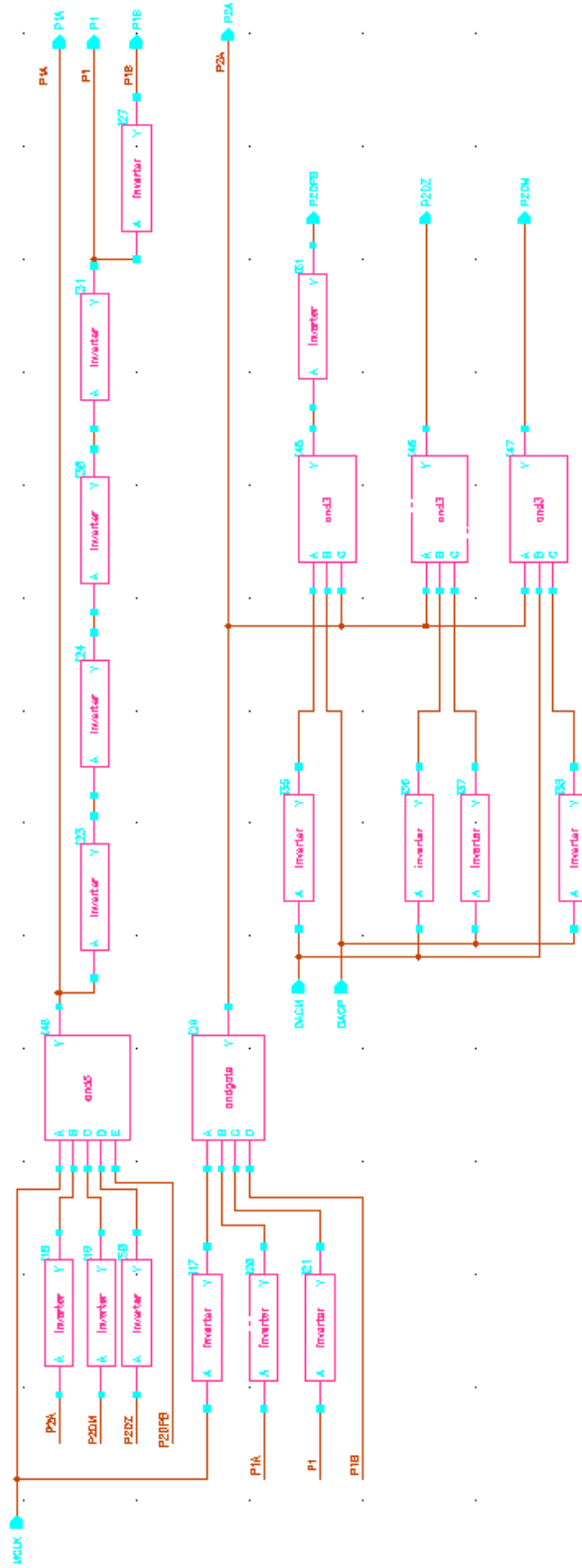

Figure 46: Clock Signals for SCN

Transient analysis of the switch capacitor was done and the following results were obtained. Our results support the theory that was explained above.

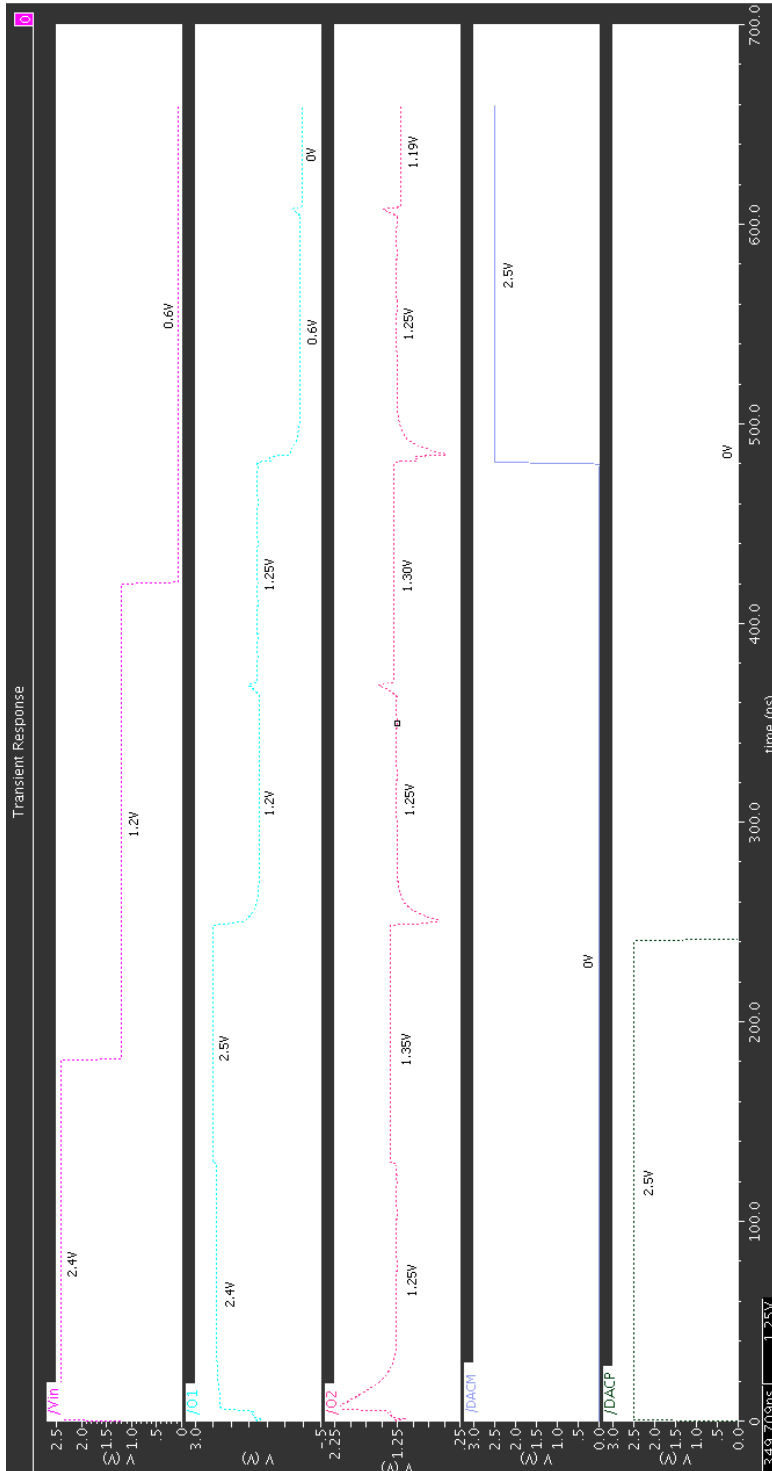

Figure 47: Transient Analysis of SCN

The schematic with the Switched capacitor and Diff-pair connected together is shown below.

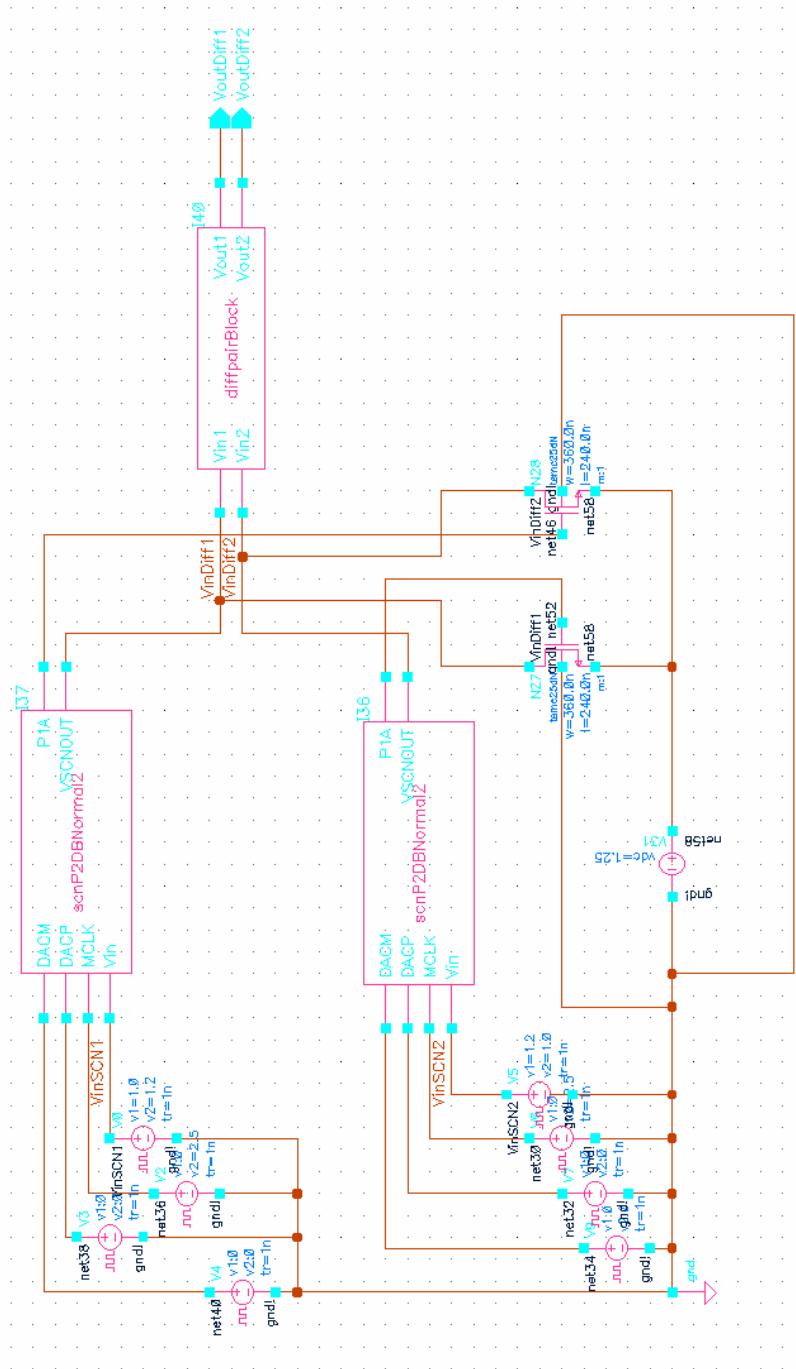

Figure 48: Schematic of Switched Capacitor Network and Diff-pair together

Further transient analysis was conducted on this new circuit, which resulted in the following results.

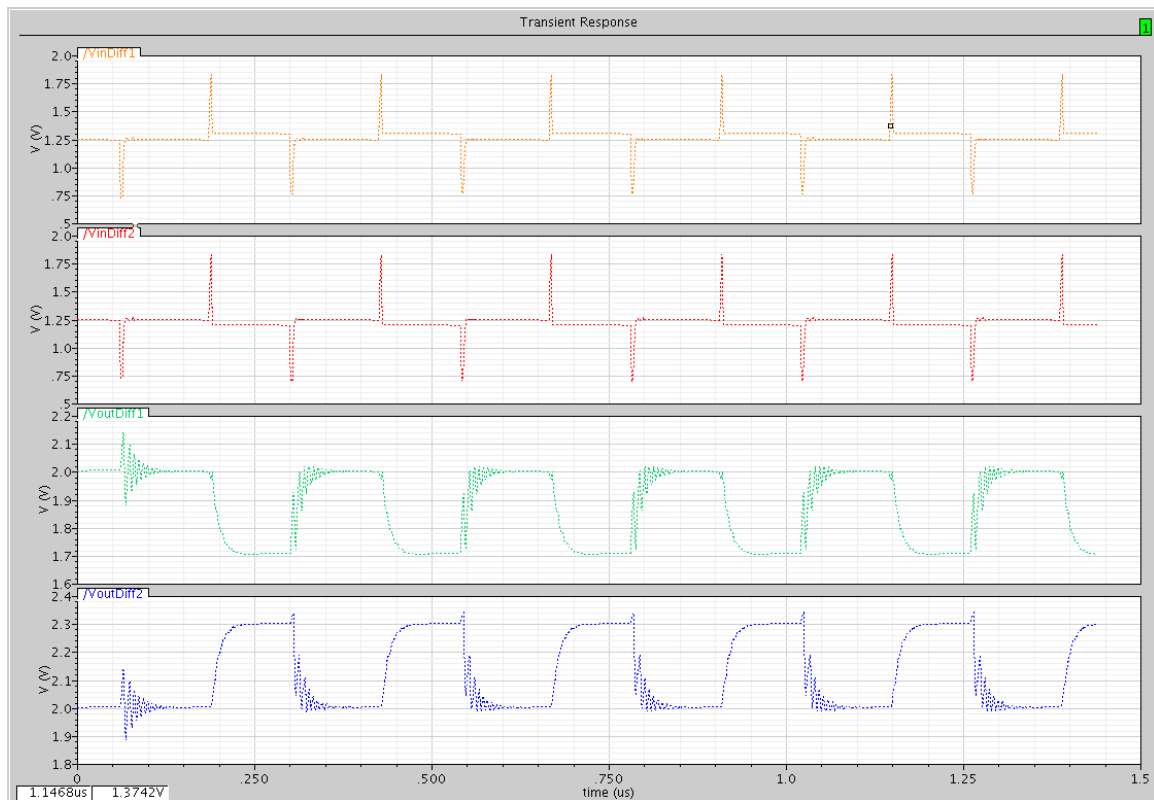

Figure 49: Transient Analysis of Switched Capacitor Network and Diff-pair together

More analysis will need to be done to measure the settling times of this process. This may result in the tweaking of the design and the adjustment of certain component values.

5. Quantizer

The design of the pipeline ADC consists of a 4-bit quantizer. The following circuit is a 2-bit quantizer designed by Tsai Chen, and we are in the process of modifying it to 4-bit. In this design the voltage reference levels are set by mismatches in the current sources. However, a main concern with that design is the 100K resistor in the preamp, which slows down the circuit.

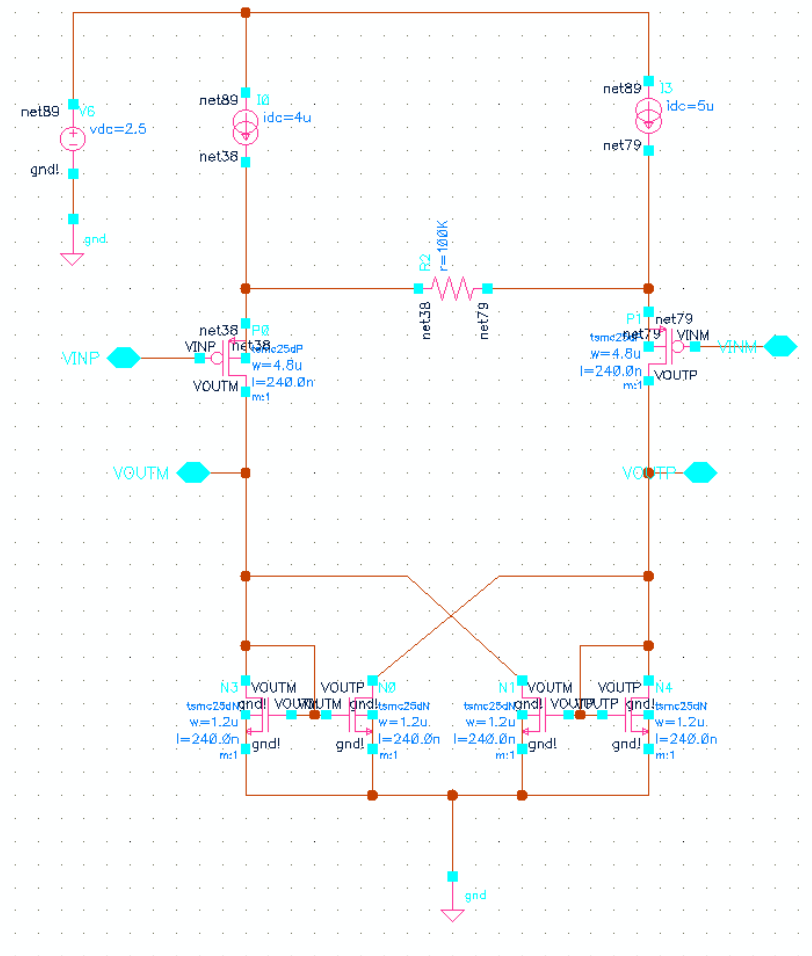

Figure 50: Preamp for the Quantizer

An alternative approach that was implemented in a 3-bit pipeline ADC by Thomas Liechti uses a differential difference amplifier with a 2 Vpp differential signal (1Vpp single ended) and centered about $V_{dd}/2$ ($=0.9V$).

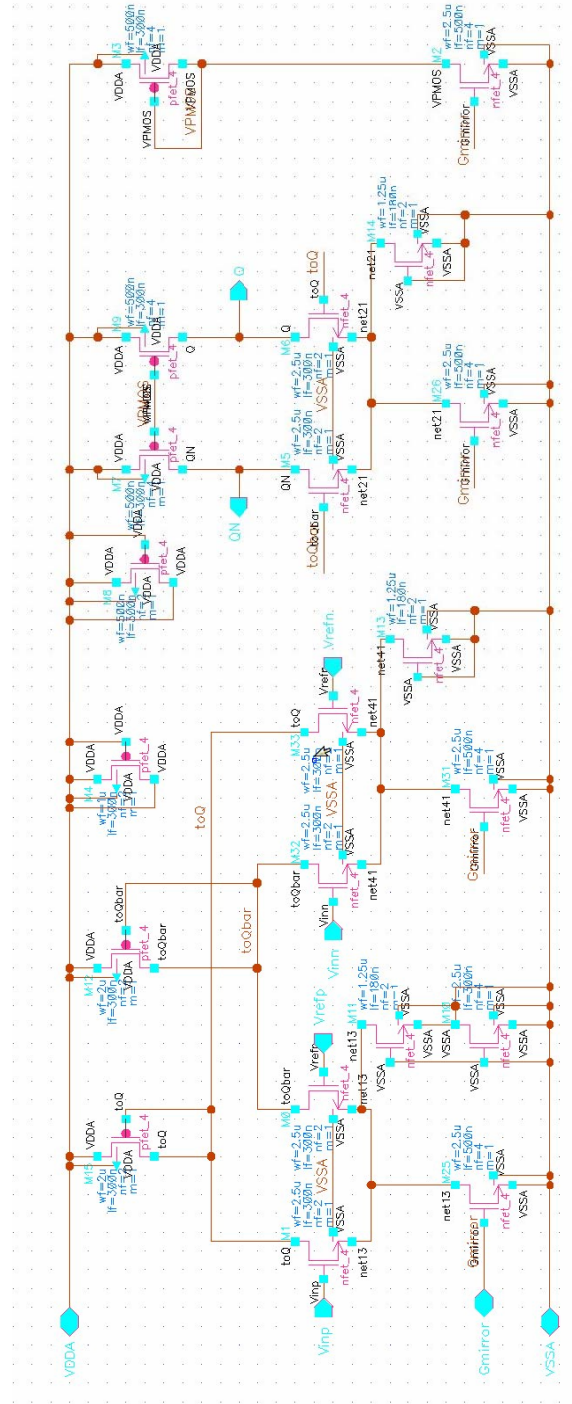

Figure 51: Alternative Approach for Quantizer

The voltage levels are generated using a resistive ladder, and this approach could work for our design.

6. Conclusion

This project has made significant progress in our aim to design a 16-bit 10Mhz Pipeline ADC. We have successfully been able to:

- characterize the System-level functionality of a Pipeline ADC by simulating its features using Matlab and
- design the majority of the analog subsystem of the ADC in Cadence.

The simulation work has corroborated our theory and helped analyze our design block. It has provided us an opportunity to compare and contrast the ideal and non ideal behavior of an ADC.

Due to the complexity of the project and the various hurdles we came upon during the design phase, we did not have enough time to be able to achieve all the goals we set out to meet initially. Some of the work that still needs to be completed includes the fabrication work including the lay out work of the analog subsystem. Once the fabricated IC has been received, further work will be needed for data acquisition using a software package similar to LabView. Further transient analysis may need to be completed on the final design block to verify its performance. Moreover, work will also need to be done on the FPGA for designing the background calibration.

7. References

- [1] J. McNeill, M. Coln, and B. Larivee, ““Split ADC” architecture for deterministic digital background calibration of a 16b 1MS/s ADC,” *IEEE J. Solid State Circuits*, Vol.40, No.12, December 2005.
- [2] D.G. Morrison, “Basics of Design: Analog to Digital Converters”, *Electronic Design*, October 13, 2003
- [3] D.A. Johns and K.Martin, “Analog Integrated Circuit Design”, John Wiley, 2002, pp. 487.
- [4] B.Murmann and B. Boser, “A 12-bit 75-MS/s Pipelined ADC Using Open-Loop Residue Amplification”, *IEEE J. Solid State Circuits*, Vol.38, No.12, December 2003.
- [5] G.N. Lu and G.Sou, “A CMOS Low-Voltage, High-Gain Op-Amp”, *IEEE Proceedings of the 1997 European Design and Test Conference*, 1997.
- [6] K.Gulati and H-S.Lee, “A high-swing CMOS telescopic Operational amplifier”, *IEEE J. Solid State Circuits*, Vol.33, pp. 2010-2019, Dec 1998.

Appendix A: Matlab Code

I. Simulating a linear multi-stage ADC

```

% simulated Vin
Vin(1,:) = 2.*(rand(1,10000)-0.5);

% code edges of each level
edges = [-1.4063, -1.2188, -1.0313, -0.8438, -0.6563, -0.4688, -0.2813,
        -0.0938, 0.0938, 0.2813, 0.4688, 0.6563, 0.8438, 1.0313,
        1.2188, 1.4063];

% # of stages in the ADC
Stages = 3;

% Analog Gain (amplification factor of error)
AGain = 6.1;

% Digital Gain (reconstruction)
DGain = 1.00 * AGain;

% Reference Voltage
Vref = 1.5;

for j = 1:Stages
    % Setting the lowest level to -8
    Nout(j,:) = zeros(size(Vin(j,:)))-8;

    for i = 1:length(edges)

        % compare each value of Vin to the code edges
        I = find ( Vin(j,:) >= edges(i) );

        % set the Nout value for each Vin
        Nout(j,I) = i-8;
    end

    % calculates the error from a stage (residue)
    Verr(j,:) = Vin(j,:) - Nout(j, :)*(Vref/8);

    % calculates the input voltage for the next stage ADC by amplifying
    % the error from the previous stage with some nonlinearity factor
    Vin(j+1,:) = AGain .* Verr(j,:);
end

```

II. Estimating Vin and ADC error from each stage

```
%% CALCULATING ESTIMATED VIN AND ADC ERROR OF EACH STAGE
for j = 1:Stages
    % estimate Vin for the first stage of the ADC
    if (j == 1)
        Vinest(j,:) = Vref*(Nout(j,+)/8);
    else
        % estimate Vin for the other stages of the ADC
        Vinest(j,:) = Vinest(j-1,:) + Vref*(Nout(j,)/(8*DGain^(j-1)));
    end
    error(j,:) = Vinest(j,)-Vin(1,);
end
```

III. Simulating a non-linear multi stage ADC

```

% simulated Vin
Vin(1,:) = 2.*(rand(1,10000)-0.5);

% code edges of each level
edges = [-1.4063, -1.2188, -1.0313, -0.8438, -0.6563, -0.4688, -0.2813,
         -0.0938, 0.0938, 0.2813, 0.4688, 0.6563, 0.8438, 1.0313,
         1.2188, 1.4063];

% # of stages in the ADC
Stages = 3;

% Analog Gain (amplification factor of error)
AGain = 6.1;

% Digital Gain (reconstruction)
DGain = 1.00 * AGain;

% Reference Voltage
Vref = 1.5;

% Non-Linearity Factor
Vnonlinfactor = 3 * Vref;

for j = 1:Stages
    % Setting the lowest level to -8
    Nout(j,:) = zeros(size(Vin(j,:)))-8;

    for i = 1:length(edges)

        % compare each value of Vin to the code edges
        I = find ( Vin(j,:) >= edges(i) );

        % set the Nout value for each Vin
        Nout(j,I) = i-8;
    end

    % calculates the error from a stage (residue)
    Verr(j,:) = Vin(j,:) - Nout(j, :)*(Vref/8);

    % calculates the input voltage for the next stage ADC by amplifying
    % the error from the previous stage with some nonlinearity factor
    Vin(j+1,:) = AGain .* Verr(j, :).*(1-(Verr(j, :).*Vnonlinfactor).^2);
end

```

IV. Simulated data from Cadence showing non-linearity

```

% simulated Vin
Vin(1,:) = 2.*(rand(1,10000)-0.5);

% simulated data imported from cadence for a 250mV overdrive
Gain250I=Gain250InputRange94mV20KDataPoints';

% code edges of each level
edges = [-1.4063, -1.2188, -1.0313, -0.8438, -0.6563, -0.4688, -0.2813,
        -0.0938, 0.0938, 0.2813, 0.4688, 0.6563, 0.8438, 1.0313,
        1.2188, 1.4063];

% # of stages in the ADC
Stages = 3;

% Analog Gain (amplification factor of error)
AGain = 6.1;

% Digital Gain (reconstruction)
DGain = 1.00 * AGain;

% Reference Voltage
Vref = 1.5;

for j = 1:Stages
    % Setting the lowest level to -8
    Nout(j,:) = zeros(size(Vin(j,:)))-8;

    for i = 1:length(edges)

        % compare each value of Vin to the code edges
        I = find ( Vin(j,:) >= edges(i) );

        % set the Nout value for each Vin
        Nout(j,I) = i-8;
    end

    % calculates the error from a stage (residue)
    Verr(j,:) = Vin(j,:) - Nout(j, :)*(Vref/8);

    % calculates the input voltage for the next stage ADC by amplifying
    % the error from the previous stage with the nonlinearity factor
    % from cadence simulated data
    for k = 1:length(Verr(j,:))
        location = length(find(Gain250I(1,:)<=Verr(j,k)))+1;
        Vin(j+1,k)=Gain250I(2,location);
    end
end
end

```

V. Correcting non-linearity of a simulated multi-stage ADC

```

% simulated Vin
Vin(1,:) = 2.*(rand(1,10000)-0.5);

% code edges of each level
edges = [-1.4063, -1.2188, -1.0313, -0.8438, -0.6563, -0.4688, -0.2813,
         -0.0938, 0.0938, 0.2813, 0.4688, 0.6563, 0.8438, 1.0313,
         1.2188, 1.4063];

% # of stages in the ADC
Stages = 3;

% Analog Gain (amplification factor of error)
AGain = 6.1;

% Digital Gain (reconstruction)
DGain = 1.00 * AGain;

% Reference Voltage
Vref = 1.5;

% Non-Linearity Factor
Vnonlinfactor = 3 * Vref;

for j = 1:Stages
    % Setting the lowest level to -8
    Nout(j,:) = zeros(size(Vin(j,:)))-8;

    for i = 1:length(edges)

        % compare each value of Vin to the code edges
        I = find ( Vin(j,:) >= edges(i) );

        % set the Nout value for each Vin
        Nout(j,I) = i-8;
    end

    % calculates the error from a stage (residue)
    Verr(j,:) = Vin(j,:) - Nout(j, :)*(Vref/8);

    % calculates the input voltage for the next stage ADC by amplifying
    % the error from the previous stage with some nonlinearity factor
    Vin(j+1,:) = AGain .* Verr(j, :).*(1-(Verr(j, :).*Vnonlinfactor).^2);

    % NON-LINEARITY CORRECTION FROM CUBIC APPROXIMATION
    coeff = polyfit(Vres(j,:),Vin(j+1,:),3);

    cubic(j,:) = coeff(1)*Vres(j,).^3 +
                 coeff(2)*Vres(j,).^2 +
                 coeff(3)*Vres(j,)+
                 coeff(4);
    Vin(j+1,:) = Vin(j+1,:)./cubic(j, :).*DGain.*Vres(j, :);
end

```

VI. Correcting non-linearity of simulated data from Cadence

```

% simulated Vin
Vin(1,:) = 2.*(rand(1,10000)-0.5);

% simulated data imported from cadence for a 250mV overdrive
Gain250I=Gain250InputRange94mV20KDataPoints';

% code edges of each level
edges = [-1.4063, -1.2188, -1.0313, -0.8438, -0.6563, -0.4688, -0.2813,
        -0.0938, 0.0938, 0.2813, 0.4688, 0.6563, 0.8438, 1.0313,
        1.2188, 1.4063];

% # of stages in the ADC
Stages = 3;

% Analog Gain (amplification factor of error)
AGain = 6.1;

% Digital Gain (reconstruction)
DGain = 1.00 * AGain;

% Reference Voltage
Vref = 1.5;

for j = 1:Stages
    % Setting the lowest level to -8
    Nout(j,:) = zeros(size(Vin(j,:)))-8;

    for i = 1:length(edges)

        % compare each value of Vin to the code edges
        I = find ( Vin(j,:) >= edges(i) );

        % set the Nout value for each Vin
        Nout(j,I) = i-8;
    end

    % calculates the error from a stage (residue)
    Verr(j,:) = Vin(j,:) - Nout(j, :)*(Vref/8);

    % calculates the input voltage for the next stage ADC by amplifying
    % the error from the previous stage with the nonlinearity factor
    % from cadence simulated data
    for k = 1:length(Verr(j,:))
        location = length(find(Gain250I(1,:)<=Verr(j,k)))+1;
        Vin(j+1,k)=Gain250I(2,location);
    end

    % NON-LINEARITY CORRECTION FROM CUBIC APPROXIMATION
    coeff = polyfit(Vres(j,:),Vin(j+1,:),3);

    cubic(j,:) = coeff(1)*Vres(j,).^3 +
                coeff(2)*Vres(j,).^2 +

```

```
        coeff(3)*Vres(j,:)+  
        coeff(4);  
    Vin(j+1,:) = Vin(j+1,:)./cubic(j,:).*DGain.*Vres(j,:) ;  
  
end
```

VII. Simulating the basics of a Split-ADC architecture

```

% input voltage to Pipeline ADC A & B
VinA(1,:) = -1.5:0.0001:1.5;
VinB(1,:) = VinA(1,:);

% code edges for ADC A
edgesA(1:5,:) = [-1.4063, -1.2188, -1.0313, -0.8438, -0.6563, -0.4688,
                -0.2813, -0.0938, 0.0938, 0.2813, 0.4688, 0.6563,
                0.8438, 1.0313, 1.2188, 1.4063;
                -1.4063, -1.2188, -1.0313, -0.8438, -0.6563, -0.4688,
                -0.2813, -0.0938, 0.0938, 0.2813, 0.4688, 0.6563,
                0.8438, 1.0313, 1.2188, 1.4063;
                -1.4063, -1.2188, -1.0313, -0.8438, -0.6563, -0.4688,
                -0.2813, -0.0938, 0.0938, 0.2813, 0.4688, 0.6563,
                0.8438, 1.0313, 1.2188, 1.4063;
                -1.4063, -1.2188, -1.0313, -0.8438, -0.6563, -0.4688,
                -0.2813, -0.0938, 0.0938, 0.2813, 0.4688, 0.6563,
                0.8438, 1.0313, 1.2188, 1.4063;
                -1.4063, -1.2188, -1.0313, -0.8438, -0.6563, -0.4688,
                -0.2813, -0.0938, 0.0938, 0.2813, 0.4688, 0.6563,
                0.8438, 1.0313, 1.2188, 1.4063];

% code edges for ADC B
edgesB(1:5,:) = [-1.4063, -1.2188, -1.0313, -0.8438, -0.6563, -0.4688,
                -0.2813, -0.0938, 0.0938, 0.2813, 0.4688, 0.6563,
                0.8438, 1.0313, 1.2188, 1.4063;
                -1.4063, -1.2188, -1.0313, -0.8438, -0.6563, -0.4688,
                -0.2813, -0.0938, 0.0938, 0.2813, 0.4688, 0.6563,
                0.8438, 1.0313, 1.2188, 1.4063;
                -1.4063, -1.2188, -1.0313, -0.8438, -0.6563, -0.4688,
                -0.2813, -0.0938, 0.0938, 0.2813, 0.4688, 0.6563,
                0.8438, 1.0313, 1.2188, 1.4063;
                -1.4063, -1.2188, -1.0313, -0.8438, -0.6563, -0.4688,
                -0.2813, -0.0938, 0.0938, 0.2813, 0.4688, 0.6563,
                0.8438, 1.0313, 1.2188, 1.4063;
                -1.4063, -1.2188, -1.0313, -0.8438, -0.6563, -0.4688,
                -0.2813, -0.0938, 0.0938, 0.2813, 0.4688, 0.6563,
                0.8438, 1.0313, 1.2188, 1.4063];

%Above edges are ideal - but because of redundancy we should be able to
%handle edges higer or lower.  Bump up, down by 1/4 LSB
edgesA(1,:) = edgesA(1,:) - .1875/4;
edgesB(1,:) = edgesB(1,:) + .1875/4;

% # of stages in the ADC
Stages = 5;

% ADC A Parameters
% Analog Gain (amplification factor of error)
AGainA = [6.5, 6.5, 6.5, 6.5, 6.5];

% Digital Gain (reconstruction)
DGainA = 1.00 * AGainA;

```

```

% Reference Voltage
VrefA = 1.5;

% Non-Linearity Factor
AlphaA = [10.0 * VrefA, 0 * VrefA, 0 * VrefA, 0 * VrefA, 0 * VrefA];

weightsA = [ 1 ;
             1/(AGainA(1)) ;
             1/(AGainA(1)*AGainA(2)) ;
             1/(AGainA(1)*AGainA(2)*AGainA(3)) ;
             1/(AGainA(1)*AGainA(2)*AGainA(3)*AGainA(4)) ]';
subweightsA = AGainA(1)*weightsA(2:5);

% ADC B Parameters
AGainB = [6.5, 6.5, 6.5, 6.5];
DGainB = 1.00 * AGainB;
VrefB = 1.5;
AlphaB = [10.0 * VrefA, 0 * VrefA, 0 * VrefA, 0 * VrefA, 0 * VrefA];

weightsB = [ 1 ;
             1/(AGainB(1)) ;
             1/(AGainB(1)*AGainB(2)) ;
             1/(AGainB(1)*AGainB(2)*AGainB(3)) ;
             1/(AGainB(1)*AGainB(2)*AGainB(3)*AGainB(4)) ]';
subweightsB = AGainB(1)*weightsB(2:5);

% Decisions NoutA, NoutB come from this part
for j = 1:Stages
    % setting the lowest code level of ADC A to -8
    NoutA(j,:) = zeros(size(VinA(j,:)))-8;

    % same as above for ADC B
    NoutB(j,:) = zeros(size(VinB(j,:)))-8;

    for i = 1:length(edgesA)
        % compare each value of Vin to the code edges for ADC A
        I = find ( VinA(j,:) >= edgesA(j,i) );

        % set the output code value for each Vin
        NoutA(j,I) = i-8;
    end

    % same as above for ADC B
    for i = 1:length(edgesB)
        I = find ( VinB(j,:) >= edgesB(j,i) );
        NoutB(j,I) = i-8;
    end

    % Previous makes -8 < N < 8
    % Fix so they go from -1 to 1
    NoutA(j,:) = (1/8)*NoutA(j,:);
    NoutB(j,:) = (1/8)*NoutB(j,:);
end

```

```
% Following is the DAC subtract function
% calculates the error of a stage for ADC A
VerrA(j,:) = VinA(j,:) - NoutA(j,)*(VrefA);

% same as above for ADC B
VerrB(j,:) = VinB(j,:) - NoutB(j,)*(VrefB);

% Then do gain and nonlinearity
% calculate input voltage for the next stage of ADC A by amplifying
% the error from the previous stage with some nonlinearity factor
VinA(j+1,:)= AGainA(j).*VerrA(j,).*(1-(VerrA(j,).*AlphaA(j)).^2);

% same as above for ADC B
VinB(j+1,:)= AGainB(j).*VerrB(j,).*(1-(VerrB(j,).*AlphaB(j)).^2);

end

% Turn decisions into CODES

% find the total code output for ADC A
CODESA = weightsA*NoutA;

% find the total code output for ADC B
CODESB = weightsB*NoutB;

% Split ADC Process - Average the two output codes!
CODES = (CODESA + CODESB)/2;

% Above are uncorrected for nonlinearity
% Nonlinearity correction needs "subCODES" which are 1st stage residues
% as measured by remaining stages of ADC
subCODESA = subweightsA*NoutA(2:5,:);
subCODESB = subweightsB*NoutB(2:5,:);
```

VIII. Simulating non-linearity from Cadence using Split-ADC architecture

```

% input voltage to Pipeline ADC A & B
VinA(1,:) = -1.5:0.0001:1.5;
VinB(1,:) = VinA(1,:);

% imported data from cadence
Gain250I=Gain250';

% code edges for ADC A
edgesA(1:5,:) = [-1.4063, -1.2188, -1.0313, -0.8438, -0.6563, -0.4688,
-0.2813, -0.0938, 0.0938, 0.2813, 0.4688, 0.6563,
0.8438, 1.0313, 1.2188, 1.4063;
-1.4063, -1.2188, -1.0313, -0.8438, -0.6563, -0.4688,
-0.2813, -0.0938, 0.0938, 0.2813, 0.4688, 0.6563,
0.8438, 1.0313, 1.2188, 1.4063;
-1.4063, -1.2188, -1.0313, -0.8438, -0.6563, -0.4688,
-0.2813, -0.0938, 0.0938, 0.2813, 0.4688, 0.6563,
0.8438, 1.0313, 1.2188, 1.4063;
-1.4063, -1.2188, -1.0313, -0.8438, -0.6563, -0.4688,
-0.2813, -0.0938, 0.0938, 0.2813, 0.4688, 0.6563,
0.8438, 1.0313, 1.2188, 1.4063;
-1.4063, -1.2188, -1.0313, -0.8438, -0.6563, -0.4688,
-0.2813, -0.0938, 0.0938, 0.2813, 0.4688, 0.6563,
0.8438, 1.0313, 1.2188, 1.4063];

% code edges for ADC B
edgesB(1:5,:) = [-1.4063, -1.2188, -1.0313, -0.8438, -0.6563, -0.4688,
-0.2813, -0.0938, 0.0938, 0.2813, 0.4688, 0.6563,
0.8438, 1.0313, 1.2188, 1.4063;
-1.4063, -1.2188, -1.0313, -0.8438, -0.6563, -0.4688,
-0.2813, -0.0938, 0.0938, 0.2813, 0.4688, 0.6563,
0.8438, 1.0313, 1.2188, 1.4063;
-1.4063, -1.2188, -1.0313, -0.8438, -0.6563, -0.4688,
-0.2813, -0.0938, 0.0938, 0.2813, 0.4688, 0.6563,
0.8438, 1.0313, 1.2188, 1.4063;
-1.4063, -1.2188, -1.0313, -0.8438, -0.6563, -0.4688,
-0.2813, -0.0938, 0.0938, 0.2813, 0.4688, 0.6563,
0.8438, 1.0313, 1.2188, 1.4063];

%Above edges are ideal - but because of redundancy we should be able to
%handle edges higer or lower. Bump up, down by 1/4 LSB
edgesA(1,:) = edgesA(1,:) - .1875/4;
edgesB(1,:) = edgesB(1,:) + .1875/4;

% # of stages in the ADC
Stages = 5;

```

```

% ADC A Parameters
% Analog Gain (amplification factor of error)
AGainA = [6.5, 6.5, 6.5, 6.5, 6.5];

% Digital Gain (reconstruction)
DGainA = 1.00 * AGainA;

% Reference Voltage
VrefA = 1.5;

% Non-Linearity Factor
AlphaA = [10.0 * VrefA, 0 * VrefA, 0 * VrefA, 0 * VrefA, 0 * VrefA];

weightsA = [ 1          ;
             1/(AGainA(1)) ;
             1/(AGainA(1)*AGainA(2)) ;
             1/(AGainA(1)*AGainA(2)*AGainA(3)) ;
             1/(AGainA(1)*AGainA(2)*AGainA(3)*AGainA(4)) ]';
subweightsA = AGainA(1)*weightsA(2:5);

% ADC B Parameters
AGainB = [6.5, 6.5, 6.5, 6.5, 6.5];
DGainB = 1.00 * AGainB;
VrefB = 1.5;
AlphaB = [10.0 * VrefA, 0 * VrefA, 0 * VrefA, 0 * VrefA, 0 * VrefA];

weightsB = [ 1          ;
             1/(AGainB(1)) ;
             1/(AGainB(1)*AGainB(2)) ;
             1/(AGainB(1)*AGainB(2)*AGainB(3)) ;
             1/(AGainB(1)*AGainB(2)*AGainB(3)*AGainB(4)) ]';
subweightsB = AGainB(1)*weightsB(2:5);

% Decisions NoutA, NoutB come from this part
for j = 1:Stages
    % setting the lowest code level of ADC A to -8
    NoutA(j,:) = zeros(size(VinA(j,:)))-8;

    % same as above for ADC B
    NoutB(j,:) = zeros(size(VinB(j,:)))-8;

    for i = 1:length(edgesA)
        % compare each value of Vin to the code edges for ADC A
        I = find ( VinA(j,:) >= edgesA(j,i) );

        % set the output code value for each Vin
        NoutA(j,I) = i-8;
    end

    % same as above for ADC B
    for i = 1:length(edgesB)
        I = find ( VinB(j,:) >= edgesB(j,i) );
        NoutB(j,I) = i-8;
    end
end

```

```

% Previous makes -8 < N < 8
% Fix so they go from -1 to 1
NoutA(j,:) = (1/8)*NoutA(j,:);
NoutB(j,:) = (1/8)*NoutB(j,:);

% Following is the DAC subtract function
% calculates the error of a stage for ADC A
VerrA(j,:) = VinA(j,:) - NoutA(j,)*(VrefA);

% same as above for ADC B
VerrB(j,:) = VinB(j,:) - NoutB(j,)*(VrefB);

% Then do gain and nonlinearity
for k = 1:length(VerrA(j,:))
    location = length(find(Gain250I(1,:)<=VerrA(j,k)));
    VinA(j+1,k)=Gain250I(2,location+1);
end

for k = 1:length(VerrB(j,:))
    location = length(find(Gain250I(1,:)<=VerrB(j,k)));
    VinB(j+1,k)=Gain250I(2,location);
end

end

% Turn decisions into CODES

% find the total code output for ADC A
CODESA = weightsA*NoutA;

% find the total code output for ADC B
CODESB = weightsB*NoutB;

% Split ADC Process - Average the two output codes!
CODES = (CODESA + CODESB)/2;

% Above are uncorrected for nonlinearity
% Nonlinearity correction needs "subCODES" which are 1st stage residues
% as measured by remaining stages of ADC
subCODESA = subweightsA*NoutA(2:5,:);
subCODESB = subweightsB*NoutB(2:5,:);

```

IX. Simulating non-linearity in the first stage of Split ADC

```

% input voltage to Pipeline ADC A & B
VinA(1,:) = -1.5:0.0001:1.5;
VinB(1,:) = VinA(1,:);

% imported data from cadence
Gain250I=Gain250';

% code edges for ADC A
edgesA(1:5,:) = [-1.4063, -1.2188, -1.0313, -0.8438, -0.6563, -0.4688,
                -0.2813, -0.0938, 0.0938, 0.2813, 0.4688, 0.6563,
                0.8438, 1.0313, 1.2188, 1.4063;
                -1.4063, -1.2188, -1.0313, -0.8438, -0.6563, -0.4688,
                -0.2813, -0.0938, 0.0938, 0.2813, 0.4688, 0.6563,
                0.8438, 1.0313, 1.2188, 1.4063;
                -1.4063, -1.2188, -1.0313, -0.8438, -0.6563, -0.4688,
                -0.2813, -0.0938, 0.0938, 0.2813, 0.4688, 0.6563,
                0.8438, 1.0313, 1.2188, 1.4063;
                -1.4063, -1.2188, -1.0313, -0.8438, -0.6563, -0.4688,
                -0.2813, -0.0938, 0.0938, 0.2813, 0.4688, 0.6563,
                0.8438, 1.0313, 1.2188, 1.4063];

% code edges for ADC B
edgesB(1:5,:) = [-1.4063, -1.2188, -1.0313, -0.8438, -0.6563, -0.4688,
                -0.2813, -0.0938, 0.0938, 0.2813, 0.4688, 0.6563,
                0.8438, 1.0313, 1.2188, 1.4063;
                -1.4063, -1.2188, -1.0313, -0.8438, -0.6563, -0.4688,
                -0.2813, -0.0938, 0.0938, 0.2813, 0.4688, 0.6563,
                0.8438, 1.0313, 1.2188, 1.4063;
                -1.4063, -1.2188, -1.0313, -0.8438, -0.6563, -0.4688,
                -0.2813, -0.0938, 0.0938, 0.2813, 0.4688, 0.6563,
                0.8438, 1.0313, 1.2188, 1.4063;
                -1.4063, -1.2188, -1.0313, -0.8438, -0.6563, -0.4688,
                -0.2813, -0.0938, 0.0938, 0.2813, 0.4688, 0.6563,
                0.8438, 1.0313, 1.2188, 1.4063];

%Above edges are ideal - but because of redundancy we should be able to
%handle edges higer or lower.  Bump up, down by 1/4 LSB
edgesA(1,:) = edgesA(1,:) - .1875/4;
edgesB(1,:) = edgesB(1,:) + .1875/4;

% # of stages in the ADC
Stages = 5;

% ADC A Parameters
% Analog Gain (amplification factor of error)
AGainA = [6.5, 6.5, 6.5, 6.5, 6.5];

```

```

% Digital Gain (reconstruction)
dGainA = 1.00 * AGainA;

% Reference Voltage
VrefA = 1.5;

% Non-Linearity Factor
AlphaA = [10.0 * VrefA, 0 * VrefA, 0 * VrefA, 0 * VrefA, 0 * VrefA];

weightsA = [ 1 ;
             1/(AGainA(1)) ;
             1/(AGainA(1)*AGainA(2)) ;
             1/(AGainA(1)*AGainA(2)*AGainA(3)) ;
             1/(AGainA(1)*AGainA(2)*AGainA(3)*AGainA(4)) ]';
subweightsA = AGainA(1)*weightsA(2:5);

% ADC B Parameters
AGainB = [6.5, 6.5, 6.5, 6.5, 6.5];
dGainB = 1.00 * AGainB;
VrefB = 1.5;
AlphaB = [10.0 * VrefA, 0 * VrefA, 0 * VrefA, 0 * VrefA, 0 * VrefA];

weightsB = [ 1 ;
             1/(AGainB(1)) ;
             1/(AGainB(1)*AGainB(2)) ;
             1/(AGainB(1)*AGainB(2)*AGainB(3)) ;
             1/(AGainB(1)*AGainB(2)*AGainB(3)*AGainB(4)) ]';
subweightsB = AGainB(1)*weightsB(2:5);

% Decisions NoutA, NoutB come from this part
for j = 1:Stages
    % setting the lowest code level of ADC A to -8
    NoutA(j,:) = zeros(size(VinA(j,:)))-8;

    % same as above for ADC B
    NoutB(j,:) = zeros(size(VinB(j,:)))-8;

    for i = 1:length(edgesA)
        % compare each value of Vin to the code edges for ADC A
        I = find ( VinA(j,:) >= edgesA(j,i) );

        % set the output code value for each Vin
        NoutA(j,I) = i-8;
    end

    % same as above for ADC B
    for i = 1:length(edgesB)
        I = find ( VinB(j,:) >= edgesB(j,i) );
        NoutB(j,I) = i-8;
    end

    % Previous makes -8 < N < 8
    % Fix so they go from -1 to 1
    NoutA(j,:) = (1/8)*NoutA(j,:);

```

```

NoutB(j,:) = (1/8)*NoutB(j,:);

% Following is the DAC subtract function
% calculates the error of a stage for ADC A
VerrA(j,:) = VinA(j,:) - NoutA(j,)*(VrefA);

% same as above for ADC B
VerrB(j,:) = VinB(j,:) - NoutB(j,)*(VrefB);

% Then do gain and nonlinearity (First Stage from Cubic
% Approximation of Simulated Data...
% thereafter no non-linearity in any stage
if (j==1)
    fitcoeffs=polyfit(Gain250I(1,:),Gain250I(2,:),3);
    cubicapprox=polyval(fitcoeffs,Gain250I(1,:));

    VinA(j+1,:)=interp1(Gain250I(1,:),cubicapprox,VerrA(j,:));
    VinB(j+1,:)=interp1(Gain250I(1,:),cubicapprox,VerrB(j,:));
else
    % calculate input voltage for the next stage of ADC A by
    % amplifying the error from the previous stage with some
    % nonlinearity factor
    VinA(j+1,:) = AGainA(j) .* VerrA(j,:) .* (1-
        (VerrA(j,:).*AlphaA(j)).^2);
    % same as above for ADC B
    VinB(j+1,:) = AGainB(j) .* VerrB(j,:) .* (1-
        (VerrB(j,:).*AlphaB(j)).^2);
end

end

% Turn decisions into CODES

% find the total code output for ADC A
CODESA = weightsA*NoutA;

% find the total code output for ADC B
CODESB = weightsB*NoutB;

% Split ADC Process - Average the two output codes!
CODES = (CODESA + CODESB)/2;

% Above are uncorrected for nonlinearity
% Nonlinearity correction needs "subCODES" which are 1st stage residues
% as measured by remaining stages of ADC
subCODESA = subweightsA*NoutA(2:5,:);
subCODESB = subweightsB*NoutB(2:5,:);

```

X. Correcting non-linearity of a Split-ADC architecture

```
% Fixer upper for ADC A
est_AlphaA=-.018;
fixer_upperA=est_AlphaA*subCODESA.^3;

corrected_CODESA = CODESA - fixer_upperA;

% Fixer upper for ADC B
est_AlphaB=-.018;
fixer_upperB=est_AlphaB*subCODESB.^3;

corrected_CODESB = CODESB - fixer_upperB;

% Error estimation
% Following tells you how to change est_AlphaA, est_alphaB
delta_corr_CODES = (corrected_CODESB - corrected_CODESA)';
err_coeff_mat = [ (subCODESB.^3)' (subCODESA.^3)' ];

% Use pinv to estimate errors
pinv(err_coeff_mat)*delta_corr_CODES;
err_est_A=-ans(2)
err_est_B=ans(1)

% Linear Approximation of output different vs. input differential
fitcoeffs=polyfit(Gain250I(1,1400:1600),Gain250I(2,1400:1600),1);
linapprox=polyval(fitcoeffs,Gain250I(1,:));
error = linapprox - cubicapprox;
```

XI. Using Split ADC to test convergence

```

% Testing convergence

% Get cadence data for cubic fit
M=csvread('Gain150mvRange3zeros.csv');

% inputs are in first column, outputs in second
% restrict fit to +/- 0.1V vin range (that's where 501:2501 comes from
% sim_vin = M(:,1);
% sim_vout = M(:,2);
sim_vin=M(501:2501,1);
sim_vout=M(501:2501,2);

% Fit cubic to simulated data
polyfit(sim_vin,sim_vout,3);
simgain=ans(3)
simalpha=ans(1)

% So equation for forward nonlin is
% vout = simgain*vin + simalpha*vin^3
% above equation will be used to calculate diff pair outputs

% Also need lookup table for p
% input over -.15 to .15 range
% just to be safe
table_vin=-0.25:0.001:0.25;

% table vout with cubic distortion
table_vout=polyval([simalpha 0 simgain 0],table_vin);

% ideal vout (linear only)
ideal_table_vout=polyval([0 0 simgain 0],table_vin);

% Error
table_error=table_vout-ideal_table_vout;

% Lookup table for error coefficients will be
% table_vout <-- use subCODES (back end ADC result) to index into this
% table_error <-- error coefficient (multiply by p for correction)

% clear workspace
clear Vin
clear VinA
clear VinB
clear NoutA
clear NoutB
clear VerrA
clear VerrB

```

```

% code edges for ADC A
edgesA(1:5,:) = [-1.4063, -1.2188, -1.0313, -0.8438, -0.6563, -0.4688,
                -0.2813, -0.0938, 0.0938, 0.2813, 0.4688, 0.6563,
                0.8438, 1.0313, 1.2188, 1.4063;
                -1.4063, -1.2188, -1.0313, -0.8438, -0.6563, -0.4688,
                -0.2813, -0.0938, 0.0938, 0.2813, 0.4688, 0.6563,
                0.8438, 1.0313, 1.2188, 1.4063;
                -1.4063, -1.2188, -1.0313, -0.8438, -0.6563, -0.4688,
                -0.2813, -0.0938, 0.0938, 0.2813, 0.4688, 0.6563,
                0.8438, 1.0313, 1.2188, 1.4063;
                -1.4063, -1.2188, -1.0313, -0.8438, -0.6563, -0.4688,
                -0.2813, -0.0938, 0.0938, 0.2813, 0.4688, 0.6563,
                0.8438, 1.0313, 1.2188, 1.4063;
                -1.4063, -1.2188, -1.0313, -0.8438, -0.6563, -0.4688,
                -0.2813, -0.0938, 0.0938, 0.2813, 0.4688, 0.6563,
                0.8438, 1.0313, 1.2188, 1.4063];

% code edges for ADC B
edgesB(1:5,:) = [-1.4063, -1.2188, -1.0313, -0.8438, -0.6563, -0.4688,
                -0.2813, -0.0938, 0.0938, 0.2813, 0.4688, 0.6563,
                0.8438, 1.0313, 1.2188, 1.4063;
                -1.4063, -1.2188, -1.0313, -0.8438, -0.6563, -0.4688,
                -0.2813, -0.0938, 0.0938, 0.2813, 0.4688, 0.6563,
                0.8438, 1.0313, 1.2188, 1.4063;
                -1.4063, -1.2188, -1.0313, -0.8438, -0.6563, -0.4688,
                -0.2813, -0.0938, 0.0938, 0.2813, 0.4688, 0.6563,
                0.8438, 1.0313, 1.2188, 1.4063;
                -1.4063, -1.2188, -1.0313, -0.8438, -0.6563, -0.4688,
                -0.2813, -0.0938, 0.0938, 0.2813, 0.4688, 0.6563,
                0.8438, 1.0313, 1.2188, 1.4063];

%Above edges are ideal - but because of redundancy we should be able to
%handle edges higer or lower.  Bump up, down by 1/4 LSB
edgesA(1,:) = edgesA(1,:) - .1875/2;
edgesB(1,:) = edgesB(1,:) + .1875/2;

% add random offsets to edges for more realistic behavior
% Seed random numberb generator for reproducible results
rand('seed',57)
pp_edge_rand=0.02;    % 10mV p-p edge randomness
edgesA=edgesA+pp_edge_rand*(rand(size(edgesA))-0.5);
edgesB=edgesB+pp_edge_rand*(rand(size(edgesB))-0.5);

% # of stages in the ADC
Stages = 5;

% ADC A Parameters
% Analog Gain (amplification factor of error)
AGainA = simgain*[1 1 1 1 1];
DGainA = 1.00 * AGainA;
% start with erroneours first gain
DGainA(1) = 1.01*DGainA(1) ;

```

```

% Digital Gain (reconstruction)
% Reference Voltage
VrefA = 1.5;
AlphaA = simalpha*[1 0 0 0 0]; % Non-Linearity Factor

% parameter for use in error correction lookup table
est_pA=0;

% ADC B Parameters
AGainB = simgain*[1 1 1 1 1];
DGainB = 1.00 * AGainB;
DGainB(1) = 0.99*DGainB(1)

VrefB = 1.5;
AlphaB = simalpha*[1 0 0 0 0];

% parameter for use in error correction lookup table
est_pB=0;

% LMS parameter
mu=1/256;
clear top_pA
clear top_pB
clear top_ADC_error

%%%%%%%%%%%%%%%%%%%%%%%%%%%%%%%%%%%%%%%%
% CONVERSIONS

% number of points in chunk
npts=32;
nchunks=6*3200;

% First of 6 chunks will stay totally random; use ramps for last 5
top_Vin=2.9*rand(1,npts*nchunks)-1.45;

% Our ramp voltages with the correct number of points (512000)
our_ramp=5.9E-6 * ((1:512000)-256000);
top_Vin(102401:614400)=our_ramp;
top_corrected_CODES = zeros(size(top_Vin));

% reserve memory for long vectors
top_pA=zeros(size(top_Vin));
top_pB=zeros(size(top_Vin));
top_ADC_error=zeros(size(top_Vin));
top_corrected_CODES=zeros(size(top_Vin));
idealCODESA=zeros(size(top_Vin));
idealCODESB=zeros(size(top_Vin));
idealCODES=zeros(size(top_Vin));
CODESALL=zeros(size(top_Vin));

for kloop=1:nchunks
    % Report ADC iteration process
    fprintf(['\b\b\b' ])
    fprintf([num2str(100*kloop/nchunks, '%03.0f' ) ])

```

```

%recalculate weights using latest gain information

weightsA = [ 1          ;
             1/(DGainA(1)) ;
             1/(DGainA(1)*DGainA(2)) ;
             1/(DGainA(1)*DGainA(2)*DGainA(3)) ;
             1/(DGainA(1)*DGainA(2)*DGainA(3)*DGainA(4)) ]';

subweightsA = DGainA(1)*weightsA(2:5);

weightsB = [ 1          ;
             1/(DGainB(1)) ;
             1/(DGainB(1)*DGainB(2)) ;
             1/(DGainB(1)*DGainB(2)*DGainB(3)) ;
             1/(DGainB(1)*DGainB(2)*DGainB(3)*DGainB(4)) ]';
subweightsB = DGainB(1)*weightsB(2:5);

% input voltage to Pipeline ADC A & B
% Noiseless input
% Vin(1,:) = 2.9*rand(1,npts)-1.45;
Vin = top_Vin((npts*(kloop-1)+1):npts*kloop);

%store all the Vin values (a total of npts*kloop)
VinALL((npts*(kloop-1)+1):npts*kloop) = Vin(1,:);

VinA = Vin + 1E-4*randn(1,npts);
VinB = Vin + 1E-4*randn(1,npts);

% Decisions NoutA, NoutB come from this part
for j = 1:Stages
    % setting the lowest code level of ADC A to -8
    NoutA(j,:) = zeros(size(VinA(j,:)))-8;
    % same as above for ADC B
    NoutB(j,:) = zeros(size(VinB(j,:)))-8;

    for i = 1:length(edgesA)
        % compare each value of Vin to the code edges for ADC A
        I = find ( VinA(j,:) >= edgesA(j,i) );
        % set the output code value for each Vin
        NoutA(j,I) = i-8;
    end

    for i = 1:length(edgesB)
        % same as above for ADC B
        I = find ( VinB(j,:) >= edgesB(j,i) );
        NoutB(j,I) = i-8;
    end

    % Previous makes -8 < N < 8
    % Fix so they go from -1 to 1
    NoutA(j,:) = (1/8)*NoutA(j,:);
    NoutB(j,:) = (1/8)*NoutB(j,:);
end

```

```

% Following is the DAC subtract function
% this makes input for differential pair
% calculates the error of a stage for ADC A
VerrA(j,:) = VinA(j,:) - NoutA(j,)*(VrefA);
% same as above for ADC B
VerrB(j,:) = VinB(j,:) - NoutB(j,)*(VrefB);

VinA(j+1,:)=polyval( [AlphaA(j) 0 AGainA(j) 0 ],VerrA(j,:));
VinB(j+1,:)=polyval( [AlphaB(j) 0 AGainB(j) 0 ],VerrB(j,:));

end

% Turn decisions into CODES
% find the total code output for A, B ADCs
CODESA = weightsA*NoutA;
CODESB = weightsB*NoutB;

% Split ADC Process - Average the two output codes!
CODES = (CODESA + CODESB)/2;

% Above are uncorrected for nonlinearity
% Nonlinearity correction needs "subCODES" which are 1st stage
% residues As measured by remaining stages of ADC
subCODESA = subweightsA*NoutA(2:5,:);
subCODESB = subweightsB*NoutB(2:5,:);

% Fixer upper for ADC A
% Uses est_pA=1
% First, find error by looking up
% recall that table is in terms of voltage so we need to
% take Vref into account going in, out of table

cubic_err_coefFA=(1/VrefA)*interp1(table_vout,table_error,VrefA*subC
ODESA);

cubic_err_coefFB=(1/VrefB)*interp1(table_vout,table_error,VrefB*subC
ODESB);

% above is coefficient for error, tweak with estimated p to
% actually correct codes
fixer_upperA=est_pA*cubic_err_coefFA;
corrected_CODESA = CODESA - fixer_upperA;

fixer_upperB=est_pB*cubic_err_coefFB;
corrected_CODESB = CODESB - fixer_upperB;

% Apply averaging for output corrected codes
corrected_CODECS = 0.5*(corrected_CODESA + corrected_CODESB);

% Error estimation
% Following tells you how to change est_AlphaA, est_alphaB
delta_corr_CODECS = (corrected_CODESB - corrected_CODESA)';
err_coeff_mat = [ (-cubic_err_coefFA)' (cubic_err_coefFB)' ...
(1/6)*subCODESA' (-1/6)*subCODESB'];

```

```

% Use pinv to estimate errors
pinv(err_coeff_mat)*delta_corr_CODES;
if cond(err_coeff_mat)<1000
    err_est_pA=ans(1);
    err_est_pB=ans(2);
    err_est_GA=ans(3);
    err_est_GB=ans(4);
else
    err_est_pA=0;
    err_est_pB=0;
    err_est_GA=0;
    err_est_GB=0;
end

% store all the codes (for plotting purposes)
CODESALL((npts*(kloop-1)+1):npts*kloop) = CODES(1,:);

est_pA=est_pA+mu*err_est_pA;
est_pB=est_pB+mu*err_est_pB;
DGainA(1)=DGainA(1)-mu*err_est_GA;
DGainB(1)=DGainB(1)-mu*err_est_GB;

top_pA(kloop)=est_pA;
top_pB(kloop)=est_pB;
top_ADC_error(kloop)=std(corrected_CODES-(1/1.5)*Vin);
top_corrected_CODES((npts*(kloop-1)+1):npts*kloop)=corrected_CODES;

% Determine ideal codes and errors
idealCODESA((npts*(kloop-1)+1):npts*kloop)=(1/VrefA)*VinA(1,:);
idealCODESB((npts*(kloop-1)+1):npts*kloop)=(1/VrefB)*VinB(1,:);
idealCODES((npts*(kloop-1)+1):npts*kloop)
    = 0.5*(idealCODESA((npts*(kloop-1)+1):npts*kloop)
    + idealCODESB((npts*(kloop-1)+1):npts*kloop));
end

% Edges for histogram
our_edges=(1/8192)*(-8191:8192);
hist_data=histc(top_corrected_CODES,our_edges);

% Calculate DNL & INL here
mean(hist_data)
DNL = (hist_data/mean(hist_data)) - 1;
INL = cumsum(DNL);

%%% PLOTTING

figure(1)
% Make up errors as a function of conversion index
total_pts=npts*nchunks
plot_rms_errors=zeros(1,total_pts);
for ploop=1:nchunks
    plot_rms_errors(((ploop-1)*npts+1):((ploop-1)*npts+npts)) = ...
        20*log10(top_ADC_error(ploop));
end
plot(plot_rms_errors,'--k','LineWidth',2)

```



```
figure (2)
% INL versus conversion index
plot ((top_corrected_CODES-idealCODES))

figure (3)
%INL versus output codes
plot (CODESALL,(top_corrected_CODES-idealCODES),'.')

figure(4)
%Plot Histogram of codes
plot(hist_data)

figure(5)
%Plot DNL
plot(DNL)
title('DNL Plot')

figure(6)
%Plot INL
plot(INL)
title('INL Plot')
xlabel('Conversion Index')
ylabel('INL[LSB]')
```

XII. Digital Look Up Table Algorithm

```

%% Digital look up table analyzing each data point in Vin.
errorGuess = zeros(1,1:length(Vin));
ans3 = zeros(1,1:length(Vin));

for i = 1 : length(Vin)
    dout = Nout(:,i)';

    ans1 = interp1(Vin(4,1:40),Vres(3,1:40),0,'linear')+dout(3)/4;
    ans2 = interp1(Vin(4,1:40),Vres(3,1:40),ans1,'linear')+dout(2)/4;
    ans3(1,i) = interp1(Vin(4,1:40),Vres(3,1:40),ans2,'linear')+
                dout(1)/4;
end

errorGuess = ((ans3(1,:) - Vin(1,:)) ./ Vin(1,:) * 100);

figure(1);
plot(Vin(1,:),errorGuess, 'b. ');
xlabel('Vin');
ylabel('Percentage Error');
title('Percentage Error vs Vin');

figure(2);
plot(Vin(1,:),ans3(1,:), 'r. ');
xlabel('Actual Vin');
ylabel('Estimated Vin');
title('Estimated Vin vs. Actual Vin');

figure(3)
plot(Vin(1,:),ans3(1,:) - Vin(1,:), 'r');
xlabel('Actual Vin');
ylabel('Error in Vin Estimation');
title('Error in Vin Estimation vs. Actual Vin');

%% Digital look up table for a particular point.
index = 10000;
FinalVin = Vin(4,index);

dout = Nout(:,index)';

ans1 = interp1(Vin(4,1:40),Vres(3,1:40),0,'linear') + dout(3)/4
ans2 = interp1(Vin(4,1:40),Vres(3,1:40),ans1,'linear') + dout(2)/4
InterpretedVin = interp1(Vin(4,1:40),Vres(3,1:40),ans2,'linear') +
                dout(1)/4

ActualVin = Vin(1,index)

if (Vin(1,index) ~= 0)
    errorGuess = ((InterpretedVin - Vin(1,index)) / Vin(1,index) * 100)
end

```

XIII. Analyzing Data

```

% Error from a stage vs. Input to the next stage
for i = 1:1
    figure(1);
    subplot(i,1,i)
    plot(Verr(i,:),Vin(i+1:,:), 'r.')
    xlabel(sprintf('ADC Error of Stage %d',i));
    ylabel(sprintf('Input Voltage to Stage %d',i + 1));
    title(sprintf('Input of Stage %d vs. Error of Stage %d',i + 1,i));
    %     axis([edges(8) edges(9) -1.5 1.5]);
end
counter = counter+1;

% Frequency of Nout of each stage
for i = 1:Stages
    figure(counter);
    hist(Nout(i,:),-8:8)
    xlabel('Nout');
    ylabel('# of Hits of each Nout');
    title(sprintf('Histogram of Nouts of Stage %d',i));
    counter=counter+1;
end

% Input of an ADC Stage vs. Actual Input
for i = 2:Stages
    figure(counter);
    subplot(Stages-1,1,i-1)
    plot(Vin(1,:),Vin(i,:), 'g.') % after 1st quantization
    xlabel('ADC Input Voltage');
    ylabel(sprintf('Input Voltage to Stage %d', i));
    title(sprintf('Input Voltage to Stage %d vs. ADC Input Voltage',
        i));
end
counter = counter+1;

% Plotting Nouts vs. Vin
figure(counter);
plot(Vin(1,:),Nout(1,:), 'r.')
xlabel('Vin');
ylabel('Nouts');
title('Nouts vs. Vin of ADC');
grid on;

counter = counter+1;

% Plotting ADC output after each stage (Estimated Vin vs. Actual Vin)
figure(counter);
plot(Vin(1,:),Vinest, '.') % after 1st quantization
xlabel('Actual Vin');
ylabel('Estimated Vin');
title('Estimated vs. Actual Vin')
grid on

```

```

counter = counter+1;

% Plotting ADC error after various stages
figure(counter);
plot(Vin(1,:),error,'.')
xlabel('Actual Vin');
ylabel('Error of ADC');
title('Error vs. Vin of ADC');
grid on;

counter = counter+1;

%% The Following code is used to analyze data using Split ADC
%% Architecture
% Input of an ADC Stage vs. Actual Input
for i = 2:Stages
    figure(1);
    subplot(Stages-1,1,i-1)
    plot(VinA(1,:),VinA(i,:),'g.') % after 1st quantization
    xlabel('ADC Input Voltage');
    ylabel(sprintf('Input Voltage to Stage %d', i));
    title(sprintf('Input Voltage to Stage %d vs. ADC Input Voltage',
i));
end

% Input of an ADC Stage vs. Actual Input
for i = 2:Stages
    figure(2);
    subplot(Stages-1,1,i-1)
    plot(VinB(1,:),VinB(i,:),'g.') % after 1st quantization
    xlabel('ADC Input Voltage');
    ylabel(sprintf('Input Voltage to Stage %d', i));
    title(sprintf('Input Voltage to Stage %d vs. ADC Input Voltage', i));
end

figure(3)
subplot(3,1,1)
    plot(VinA(1,:),CODES)
    xlabel('Input Voltage to Pipeline ADC');
    ylabel('Pipeline ADC Output');
    title('Pipeline ADC Performance');
subplot(3,1,2)
    plot(VinA(1,:),subCODESA)
    xlabel('Input Voltage to Pipeline ADC');
    ylabel('Sub Codes of ADC A');
    title('Sub Codes of ADC A');
subplot(3,1,3)
    plot(VinB(1,:),subCODESB)
    xlabel('Input Voltage to Pipeline ADC');
    ylabel('Sub Codes of ADC B');
    title('Sub Codes of ADC B');

```

```

figure(4)
% Look at residuals after linear fit for ADC A
% fitcoeffs=polyfit(VinA(1,:),CODESA,1);
% idealCODESA=polyval(fitcoeffs,VinA(1,:));
% overwrite
    idealCODESA=(1/1.5)*VinA(1,:);
subplot(2,1,1)
    hold off
    plot(VinA(1,:),CODESA-idealCODESA)
    hold on
    plot(VinA(1,:),fixer_upperA,'r')
    title('error of original codes (blue); fixer upper (from estimated
Alpha)')
subplot(2,1,2)
    plot(VinA(1,:),corrected_CODESA-idealCODESA,'g')
    title('error of corrected codes')

figure(5)
% Look at residuals after linear fit for ADC B
% fitcoeffs=polyfit(VinB(1,:),CODESB,1);
% idealCODESB=polyval(fitcoeffs,VinB(1,:));
% overwrite fit with ideal
    idealCODESB=(1/1.5)*VinB(1,:);
subplot(2,1,1)
    hold off
    plot(VinB(1,:),CODESB-idealCODESB)
    hold on
    plot(VinB(1,:),fixer_upperB,'r')
    title('error of original codes (blue); fixer upper (from estimated
Alpha)')
subplot(2,1,2)
    plot(VinB(1,:),corrected_CODESB-idealCODESB,'g')
    title('error of corrected codes')

figure(6)
plot(subCODESA.^3,CODESA-idealCODESA,'r.')
    xlabel('Sub Codes A Cubed');
    ylabel('Errors A');

figure(7)
plot(subCODESB.^3,CODESB-idealCODESB,'r.')
    xlabel('Sub Codes B Cubed');
    ylabel('Errors B');

% Figure showing A, B residues
figure(8)
    hold off
plot(VinA(1,:),VinA(2,:),'r.') % after 1st quantization
    hold on
plot(VinB(1,:),VinB(2,:),'b.') % after 1st quantization
    xlabel('Input Voltage to First Stage');
    ylabel('Input Voltage to Second Stage');
    legend('Residues of ADC A First Stage', 'Residues of ADC B First
Stage');

```

```
figure(9)
plot(subCODESB,subCODESB.^3,'r.')
    xlabel('subCODESB');
    ylabel('subCODESB^3');

figure(10)
plot(Gain250I(1,:),Gain250I(2,:))
    xlabel('Vid (V)');
    ylabel('Vod (V)');
    hold on;
    plot(Gain250I(1,:),linapprox);

figure(11)
plot(Gain250I(2,:),error)
    xlabel('Vod (V)');
    ylabel('Error (V)');
    hold on;
% axis([-0.094 0.094 -0.001 0.001]);
```

Appendix B: Design of a Basic Diff-Pair Circuit for various V_{ov}

The goal is to design a diff-pair with a differential gain of 8 for various overdrive voltages. The four overdrive voltages of interest are: 150, 200, 250, and 300mV.

1. Choose W/L ratio for MOSFETs M1 and M2. This is done by using the “square-law” equation in the active region, where $V_{ov} = 0.15\text{mV}$ in the first case.

$$I_d = \frac{\mu_n C_{ox}}{2} * \frac{W}{L} * (V_{eff})^2$$

$$100\mu = 108.6 * (W/L) * (0.15)^2$$

Therefore, $W/L = 20.46$. Since $L = 0.24\mu\text{m}$, $W = 4.91\mu\text{m}$ for M1 and M2

2. Calculate transconductance g_m of M1 and M2. Since

$$g_m = \sqrt{2\mu_n C_{ox} * I_d * \left(\frac{W}{L}\right)}, \text{ where } I_d = 100\mu / 2 = 50\mu$$

$$g_m = \sqrt{2 * 217.2 * 10^{-6} * 50 * 10^{-6} * 20.46}$$

Therefore, $g_m = 6.67 * 10^{-4} \Omega^{-1}$ for both M1 and M2

3. Find R_{D1} , R_{D2} for a gain of 8

$$\text{Gain} = g_m * R_{D1}$$

$$8 = 6.67 * 10^{-4} * R_{D1}$$

Therefore, $R_{D1} = 12\text{K}\Omega$. Similarly, $R_{D2} = 12\text{K}\Omega$.

Steps 1-3 were repeated for the other overdrive voltages: 200, 250, and 300mV. The results are summarized in the table below:

Table 5: Circuit Parameters for Basic Differential Pair circuit

Overdrive Voltage [mV]	W [μm] for M1, M2	Load Resistance [K Ω]
150	4.91	12
200	2.76	16
250	1.77	20
300	1.23	24

Appendix C: Design of a Cascode Diff-Pair with Split Current Approach

1. Transconductance: $G_m = 2I_D / V_{OV} = 200\mu\text{A} / 0.25\text{V} = 8 \cdot 10^{-4} \text{ A/V}$
2. Differential Gain: $\text{Gain} = G_m R_D$. Therefore $R_D = 8 / 8 \cdot 10^{-4} = 10\text{K } \Omega$
3. Load Resistor: $R_D = R_B \parallel \frac{R_G}{2} = 10\text{K } \Omega$
4. Output Bias Voltage: $V_{BIAS} = V_{DD} - I_D R_B$.
 $2 = 2.5 - I_D R_B \Rightarrow I_D R_B = 0.5$
5. Differential Swing: $\text{Voltage} = I_D R_D$
 $0.4 = I_D * 10\text{K } \Omega$
 $I_D = 40 \mu\text{A}$
6. Fraction, x: $\left(\frac{1}{2} - x\right) I_{BIAS} = 40 \mu\text{A}$, since $I_{BIAS} = 200 \mu\text{A}$, $x = 3/10$
7. Resistor R_B : $R_B = 0.5\text{V} / 40 \mu\text{A} = 12.5\text{K } \Omega$
8. Resistor R_G : $100\text{K } \Omega$ to satisfy $R_B \parallel \frac{R_G}{2} = 10\text{K } \Omega$
9. Input MOSFETs: $I_D = \frac{\mu_n C_{OX}}{2} * \frac{W}{L} * (V_{eff})^2$
 $200\mu = 108.6 * (W/L) * (0.25)^2$
 $W/L = 14.73 \Rightarrow W = 3.53\mu\text{m}$
10. Cascode MOSFETs: $40\mu = 108.6 * (W/L) * (0.15)^2$
 $W/L = 16.37 \Rightarrow W = 3.93 \mu\text{m}$

Therefore $40 \mu\text{A}$ comes through the load resistor, and $60 \mu\text{A}$ comes from the Common Mode Control when output bias points are at 2V .

Table 6: Component Parameters for Diff-Pair with CMFB and Replica Bias

Component	Description	W[μm] for FETs , and R[K Ω] for Resistors
M1, M2	Input	3.54
M3, M4	Cascode	3.96
M5	Diff-Pair Bias	7.06
M6	CMFB Bias	1.02
M7, M8	CMFB Input	0.54
M9, M10	CMFB Load	2.16
M11, M12	CMFB Control	8.7
M13	Replica Bias Load	0.42
M14, M15	Replica Bias Input	0.42
M16	Replica Bias Bias	0.84
R _B	Common Mode	12.5
R _G	Differential Mode	100