

THE EFFECT OF KNEE PADS ON GAIT AND COMFORT

By

Thomas Castagno

A Thesis presented

to the Faculty of

WORCESTER POLYTECHNIC INSTITUTE

in partial fulfillment of the requirements for the

Degree of Master of Science

in

Mechanical Engineering

by

---

Thomas Castagno  
May 2004

APPROVED:

---

Professor Allen H. Hoffman, Ph. D, Major Advisor

---

Leif Hasselquist, Ph.D, U.S. Army Natick Soldier Center, Committee Member

---

Professor Holly K. Ault, Ph.D, Committee Member

---

Professor Brian J. Sivilonis, Ph.D, Committee Member

---

Professor John M. Sullivan, Ph.D, Graduate Committee Rep.

**ABSTRACT:**

The goals of this thesis were: (1) to develop a data acquisition system for measuring gait parameters and (2) to determine the effect of knee pads on gait and comfort. The data acquisition system consisted of a data acquisition card that was inserted in the PC card (PCMCIA) slot of a laptop computer, a knee goniometer, foot switches, and pressure sensors. Various drive circuits were designed to connect the different sensors to the data acquisition card. The gait analysis results showed that the knee pads do not have a significant effect on long range gait correlations calculated from the stride interval. Pressure measurements between the knee pads and the knee showed that a pressure in the range of 0 to 8.31 psi occurred when kneeling. The maximum pressure for the sensor located under the top strap of the knee pad occurred when getting into and out of the kneeling stance. The data acquisition system successfully met the design objectives. The stride interval was recorded and analyzed, and pressures were successfully measured and analyzed.

## **Acknowledgements**

There are a few people that I would like to thank that helped to make this project possible.

Professor Allen Hoffman for being my advisor and patiently tolerating my horrible editing skills.

Professor Holly Ault, Professor Brian Savilonis, Dr. Leif Hasselquist and Professor John Sullivan for serving on my thesis committee.

The guys in the machine shop, Steve, Todd and Jim for being willing to help me with all the little things I had to make.

The women of HL130; Janice, Pam, Barbara F., and Barbara E. for being a continual encouragement and making a lot of things possible.

Professor Bill Weir, for continually pushing me to finish and get out of here.

My roommates and the girls across the street for supporting me and listening to me when I get frustrated.

My family; Mom, Dad, Laura, Eddy, Taylor and Bill for their everlasting love and support in all that I do.

Finally I would like to thank God, for with out Him, none of this would have been possible.

# Table of Contents

<b>ABSTRACT:</b> .....	<b>i</b>
<b>Acknowledgements</b> .....	<b>ii</b>
<b>Table of Contents</b> .....	<b>iii</b>
<b>List of Figures</b> .....	<b>v</b>
<b>List of Tables</b> .....	<b>vii</b>
<b>Chapter 1: Introduction</b> .....	<b>1</b>
Section 1.1: Army Applications.....	1
Section 1.2: Purpose of Research.....	3
<b>Chapter 2: Background</b> .....	<b>5</b>
Section 2.1: Literature Review .....	5
Section 2.2: Use of Fractals in Gait Analysis .....	7
Section 3.1: Development of the Data Acquisition System.....	16
Section 3.1.1: Sensors .....	17
Section 3.1.1.1: Force Sensors.....	18
Section 3.1.1.1.1: Drive Circuit .....	19
Section 3.1.1.2: Knee Goniometers .....	20
Section 3.1.1.2.1: Goniometer Drive Circuit .....	21
Section 3.1.1.3: Foot Switches.....	22
Section 3.1.1.3.1: Foot Switch Drive Circuit.....	23
Section 3.2: Data Acquisition .....	24
Section 3.3: Comfort Analysis.....	25
Section 3.4: Gait Analysis.....	30
Section 3.5: Subjects Used.....	32
Section 3.6: Data Processing.....	32
Section 3.6.1: Gait Analysis.....	32
Section 3.6.2: Comfort Analysis.....	35
<b>Chapter 4: Results</b> .....	<b>36</b>
Section 4.1: Gait analysis.....	36
Section 4.2 Pressure Measurement .....	40
<b>Chapter 5: Discussion</b> .....	<b>49</b>
Section 5.1 Data collection system .....	49
Section 5.1.1 Force Sensors .....	49
Section 5.1.2: Knee Goniometer.....	50
Section 5.1.3 Foot Switches.....	51
Section 5.1.4: Comparison of foot switches and goniometer .....	52
Section 5.2 Data Analysis .....	53
Section 5.2.1 Gait Analysis.....	53
Section 5.2.2 Pressure Analysis.....	55
Section 5.3: Sample Size.....	57
<b>Chapter 6: Conclusions:</b> .....	<b>58</b>
<b>Chapter 7: Recommendations</b> .....	<b>60</b>
<b>References:</b> .....	<b>61</b>

<b>APPENDIX A: Sensor Calibration Equations .....</b>	<b>63</b>
<b>APPENDIX B: MatLab Code .....</b>	<b>64</b>
Gait Analysis: Foot switches .....	64
Gait Analysis: Knee Goniometer .....	65
<b>APPENDIX C: Gait Analysis for Subjects .....</b>	<b>66</b>
Subject 1: .....	66
Subject 2: .....	69
Subject 3: .....	72
Subject 4: .....	75
Subject 5: .....	77
Subject 6: .....	79
<b>APPENDIX D: Pressure Results For Subjects after filtering.....</b>	<b>81</b>
Subject 1: .....	81
Subject 2: .....	82
Subject 3: .....	83
Subject 4: .....	84
Subject 5: .....	85
Subject 6: .....	86
<b>APPENDIX E: Survey Results .....</b>	<b>87</b>
Subject 1 Foot wear: athletic shoe .....	87
Subject 2 Foot wear: casual shoe .....	89
Subject 3 Foot wear: athletic shoe .....	91
Subject 4 Foot wear: athletic shoe .....	93
Subject 5 Foot wear: athletic shoe .....	95
Subject 6 Foot wear: athletic shoe .....	97
<b>APPENDIX F: Informed Consent Form .....</b>	<b>99</b>
<b>APPENDIX G: Signal filtering .....</b>	<b>100</b>
<b>APPENDIX H: Detrended Fluctuation Analysis .....</b>	<b>103</b>

## List of Figures

Figure 1: The Gait Cycle (Perry 92) .....	6
Figure 2: (a)A Fractal of repeating triangles increasing in number and decreasing in size to form a triangle within a triangle and continuing smaller, (b) and (c) example of a repeating pattern in a shoreline. ....	8
Figure 3: Fractal Gait Patterns (Hausdorff 1995), (A) original stride interval, (B) shuffled stride interval, (C) scaling exponents of original and shuffled stride intervals.....	11
Figure 4: Basic layout of the data acquisition system.....	17
Figure 5: (a) Pressure sensor on anterior side of the knee (b) Pressure sensor on posterior side of the knee over tendons.....	18
Figure 6: Wiring diagram for pressure sensor .....	20
Figure 7: Wiring diagram for Goniometer.....	22
Figure 8: Wiring diagram for foot switch.....	23
Figure 9: Follow up survey asked of participants.....	30
Figure 10: Adjusted Time Series depicting the addition of two sequential stride intervals of short duration to form one stride interval.....	34
Figure 11: Stride Interval time series.....	36
Figure 12: Detrended Fluctuation Analysis of time series.....	37
Figure 13: Location of Sensors 1, 2 and 3 .....	40
Figure 14: Typical Knee Angles and Pressures beneath kneepad while undertaking various activities (Subject 6), (a) Knee angle, (b) Pressure Sensor 1, (c) Pressure Sensor 2, (d) Pressure Sensor 3.....	41
Figure 15: Normalized values for Task 1, ascending stairs.....	42
Figure 16: Normalized values for Task 2, descending stairs.....	42
Figure 17: Normalized values for Task 3, kneeling on left knee.....	43
Figure 18: Normalized values for Task 4, kneeling on right knee.....	44
Figure 19: Normalized values for Task 5, kneeling on both knees .....	44
Figure 20: Values for Sensor 1 by subject for different tasks.....	45
Figure 21: Values for Sensor 2 by subject for different tasks.....	46
Figure 22: Values for Sensor 3 by subject for different tasks.....	46
Figure 23: Knee Angle.....	47
Figure 24: Pressure Sensor 1, pressure reading peaks for going into and out of kneeling position.....	47
Figure 25: Results of the knee pad survey, n = 6.....	48
Figure 26: Left foot with knee pads.....	66
Figure 27: Left foot without knee pads.....	66
Figure 28: Right foot with knee pads.....	67
Figure 29: Right foot without knee pads.....	67
Figure 30: Left knee with knee pads.....	68
Figure 31: Left knee without knee pads.....	68
Figure 32: Left knee with knee pads.....	69
Figure 33: Left knee without knee pads.....	69
Figure 34: Left foot with knee pads.....	70
Figure 35: Left foot without knee pads.....	70

Figure 36: Left knee with knee pads.....	71
Figure 37: Left knee without knee pads.....	71
Figure 38: Left foot with knee pads.....	72
Figure 39: Left foot without knee pads.....	72
Figure 40: Right foot with knee pads.....	73
Figure 41: Right foot without knee pads.....	73
Figure 42: Left knee with knee pads.....	74
Figure 43: Left knee without knee pads.....	74
Figure 44: Left foot with knee pads.....	75
Figure 45: Left foot without knee pads.....	75
Figure 46: Right foot with knee pads.....	76
Figure 47: Right foot without knee pads.....	76
Figure 48: Left foot with knee pads.....	77
Figure 49: Left foot without knee pads.....	77
Figure 50: Right foot with knee pads.....	78
Figure 51: Right foot without knee pads.....	78
Figure 52: Left foot with knee pads.....	79
Figure 53: Left foot without knee pads.....	79
Figure 54: Right foot with knee pads.....	80
Figure 55: Right foot without knee pads.....	80
Figure 56: Pressure results for subject 1: (a) knee angle, (b) sensor 1, (c) sensor 2, (d) sensor 3 .....	81
Figure 57: Pressure results for subject 2: (a) knee angle, (b) sensor 1, (c) sensor 2, (d) sensor 3 .....	82
Figure 58: Pressure results for subject 3: (a) knee angle, (b) sensor 1, (c) sensor 2, (d) sensor 3 .....	83
Figure 59: Pressure results for subject 4: (a) knee angle, (b) sensor 1, (c) sensor 2, (d) sensor 3 .....	84
Figure 60: : Pressure results for subject 5: (a) knee angle, (b) sensor 1, (c) sensor 2, (d) sensor 3 .....	85
Figure 61: Pressure results for subject 6: (a) knee angle, (b) sensor 1, (c) sensor 2, (d) sensor 3 .....	86
Figure 62: Signal recorded from DAQ system .....	100
Figure 63: Binary time signal .....	100
Figure 64: Time signal after averaging filter .....	101
Figure 65: Filtered time signal.....	101
Figure 66: Initial stride interval time series .....	102
Figure 67: Final stride interval time series .....	102
Figure 69: Integrated time series.....	103

## List of Tables

Table 1: Selected questions and responses for the Bijan kneepad from U.S. Army survey (1998).....	3
Table 2: The Gait Cycle.....	6
Table 3: $\alpha$ coefficient and its significance .....	10
Table 4: Inter and Intra-limb temporal and spatial parameters (Taylor, 2001). .....	13
Table 5: Force Sensor Performance (www.tekscan.com).....	19
Table 6: Specifications of Motion Lab Systems SB180 goniometer.....	21
Table 7: Foot Switch Properties.....	23
Table 8: Functional Tasks.....	26
Table 9: $\alpha$ coefficient and $R^2$ values for multiple subjects .....	38
Table 10: Wilcoxon signed-rank test to test for knee pads altering the stride interval.....	39
Table 11: Wilcoxon signed-rank test to test for variations in stride interval from left to right legs.....	39
Table 12: Comparison of the stride interval with knee pads to without knee pads .....	39
Table 13: Comparison of the stride interval of left foot to right foot .....	39
Table 14: Integrated time signal .....	104
Table 15: Detrended time signal.....	106

## **Chapter 1: Introduction**

The use of knee pads during activities that require a lot of kneeling has proved to both reduce the number of knee related injuries and increase productivity. A study performed on coal miners, who are on their knees most of the day, found with the use of knee pads the miners suffered far fewer injuries to their knees according to the US department of Labor Mine safety and Health Administration. NIOSHA recommends that for personnel who are required to do a lot of kneeling on the job, mostly construction workers, the companies provide knee pads to their employees. This will reduce knee injuries and increase productivity. The use of knee pads is also recommended during recreational activities, such as snowboarding where the use of knee pads helps to cushion a fall and not only reduces knee injuries but also hand and wrist injuries.

### **Section 1.1: Army Applications**

The US Army is currently issuing knee pads to its soldiers for training and field use. The amount of use the knee pads receives depends upon the activities the soldier is performing. Regardless of the amount of use, the knee pads are required to meet certain specifications. The knee pads need to stay in place, be comfortable, protect the knee against various surfaces including sharp rocks and glass, dry quickly if they get wet and don, doff and adjust easily.

In the field and during training, the use of knee pads has helped reduce the risk of knee injury. The knee pads become essential pieces of equipment for personnel who have to move around a lot and dive to their knees frequently. For example, mortar men and rangers make extensive use of the knee pads. Mortar men are soldiers who fire their weapon, get up and run to a new location, dive to their knees and fire their weapon again. These soldiers have noted that the currently issued knee pads are bulky and cause binding

on the back of their knee during use. In some cases mortar men have purchased their own knee pads instead of using the currently issued ones.

In letters to the Editor in the *Military Medicine* publication Joseph Carvalho, Jr., M.D. of the 75<sup>th</sup> Ranger Regiment writes. “Overall, the pads made ‘taking a knee’ during patrol halts much easier and I performed individual movement techniques with greater mobility. Heavy loads prompted me to instinctively drop down onto my padded knee, as opposed to kneeling slowly and with more control. The greatest direct benefit, however, was the relief from the snow and cold ground when assuming the prone fighting position. ... Without fail, every Ranger student who wore knee protection agreed with its utility” (Carvalho 1992).

John F. Kragh, Jr., M.D., a Battalion Surgeon also agreed with the use of knee pads for Rangers. He also stated he developed a knee injury while going through ranger training, at which point he was given a prescription and started using knee pads. Upon using the knee pads the knee injury went away and did not return. He also observed that those who wore the knee pads suffered fewer problems. (Kragh 1993)

There currently exists a need to find quantitative answers to the question, “Why are some knee pads more comfortable and effective than others”? It is necessary to determine quantitative measures that indicate whether or not a knee pad is comfortable and effective. Examples of quantitative measurements are the range of motion of the knees with and without the knee pads, the pressure the knee pad exerts on the back of the knee, and potential alterations of the gait pattern caused by the knee pads.

In 1998 the US Army conducted a survey evaluating five commercially available knee pads. Although the knee pads were different in design they had to meet certain specifications, such as color, and were required to have a hard knee covering. Different

brands of knee pads were distributed to Army personnel for a period of time. At the end of this period the soldiers were asked to fill out a survey which ranked the knee pads on their performance including, but not limited to, the areas of comfort, mobility, ease of donning and doffing and how quickly they dried, (See Appendix A for the complete survey). The highest rated knee pads were the Bijan knee pads and the worst were the Bike knee pads.

Although there was a clear distinction between the knee pads tested, the results of the survey were qualitative and depended on the opinions of soldiers. This raises the question as to whether or not quantitative tests can be developed to support these qualitative results.

In an effort to quantify the answers, survey questions were selected and evaluated to determine if associated quantitative tests could be developed. The questions selected are the responses for the Bijan knee pad (Table 1).

Question	% answered yes
Did the knee pad stay properly attached to your knees during movement (Individual movement training (IMT), firing weapon, etc...)	74
Did the item restrict your range of motion	12.5
Did the test item restrict your circulation	8

**Table 1: Selected questions and responses for the Bijan kneepad from U.S. Army survey (1998)**

More recent discussion with Leif Hasselquist Ph. D. of the U.S. Army Natick Soldier Center revealed that some soldiers are complaining that the currently issued Bijan knee pads are uncomfortable because they cause binding behind the knee and slip during use. These complaints were addressed in the survey.

## **Section 1.2: Purpose of Research**

Despite the important role kneepads have in protecting soldiers, little is known about their effect on soldiers. The following two areas were investigated: the overall comfort of the kneepads and the effect of the kneepads on long term gait patterns. The results of this research will provide an understanding of how knee pads affect people. This new information could be used to improve the design of the kneepads and minimize any undesired effects.

As part of this thesis, a relatively low cost and highly portable gait analysis system was developed that is capable of simultaneously measuring knee angles, stride intervals and knee pad forces. This gait system will be useful in conducting further gait studies.

## **Chapter 2: Background**

In order to understand how knee pads affect gait, it is necessary to understand both undisturbed and altered gait patterns and also understand the different properties of gait and how to measure them.

### **Section 2.1: Literature Review**

Walking is simply the action of putting one foot ahead of the other to cause your body to move in a desired path. “As the body moves forward, one limb serves as a mobile source of support while the other limb advances itself to a new support site. Then the limbs reverse their roles. For the transfer of body weight from one limb to the other, both feet are in contact with the ground. This series of events is repeated by each limb with reciprocal timing until the person’s destination is reached” (Perry 1992). This sequence of events describes human gait. A gait cycle is a single sequence of this function. Within this sequence there are multiple phases that contribute to a single cycle. Starting with the right leg, the right heel makes contact with the ground (initial dual stance) while the left foot is still on the ground. The left foot then leaves the ground and the weight of the person is supported on the right foot (single limb stance) until the left heel makes contact with the ground (terminal dual stance). The right foot then leaves the ground (swing) and the gait cycle is completed when the right heel makes contact with the ground again. Table 2.1 breaks down the gait cycle showing the percent of the time spent in each phase of the gait cycle. Figure 1 illustrates the breakdown of the gait cycle for both left and right leg.

Term	Definition	% Gait Cycle
initial dual stance	time from right heel strike to left foot toe off	10
single limb stance	time when only the right foot is touching the ground	40
terminal dual stance	time from left heel strike to right foot toe off	10
swing	time when the right foot is in the air	40

**Table 2: The Gait Cycle**

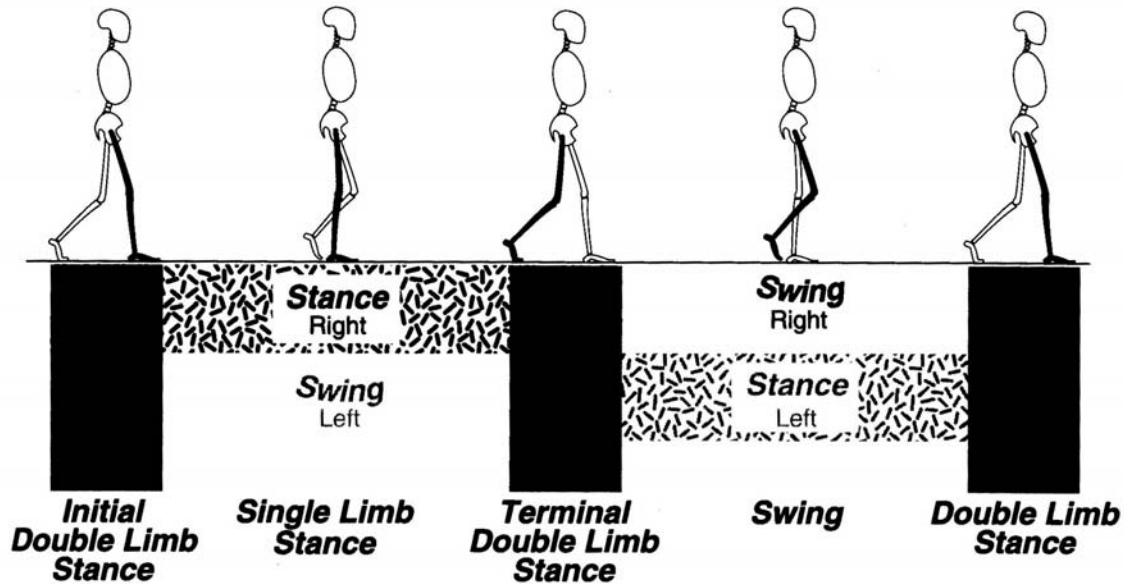

**Figure 1: The Gait Cycle (Perry 92)**

When walking, the number of steps a person takes in a minute is defined as cadence. Normal free gait averages 82 meters per minute,  $\pm 7\%$ , and varies in cadence from 101 to 122. As people grow older the variance in gait parameters increases. Women tend to have a higher cadence than men by 6 to 11 steps per minute, however men are on average 5% faster than women and have a longer stride length (1.46 m) than women (1.28m). This is a result of having longer legs on average, longer legs result in longer stride length and higher walking speeds. This is also observable in children where they are constantly growing and their stride length increases significantly until approximately age 11.

Many methods are used to analyze gait. Kinetic, kinematic, temporal and spatial methods are commonly used. In kinetics, forces that exist between a person and an object are measured and analyzed. In gait these are generally the ground reaction forces. By using inverse dynamics, forces and moments generated by the muscles, across a joint, can be calculated. However “There are many combinations of muscle forces that can result in the same movement pattern... demonstrating the tremendous flexibility and adaptability of our neuromuscular system” (Winter, 1991). In a kinematic analysis, limb and joint positions, velocities and accelerations independent of forces are measured and analyzed. Often times in gait analysis one gait cycle is examined due to the repetitive nature of gait. A temporal analysis examines kinetic or kinematic data as a function of time, or examines the time frequency of a specific task. In walking, the time of one gait cycle is described as a stride interval and multiple successive intervals are recorded over a period of time creating a stride interval time series. A spatial analysis examines kinetic or kinematic data as a function of position, or determines the position of a specific body part during repetitive motions. The minimum foot clearance of a foot during a gait cycle measured over multiple cycles or the maximum knee flexion angle are good examples of a spatial analysis.

## **Section 2.2: Use of Fractals in Gait Analysis**

Using a temporal analysis, Hausdorff (1999) developed a technique to determine long range correlations in the stride interval through the use of fractals. What was once thought to be random noise has turned out to be evidence that there are long term patterns in gait.

The use of fractals to analyze data and geometric shapes is becoming more common in the scientific community. Fractals are, “A geometric pattern that is repeated

at ever smaller scales to produce irregular shapes and surfaces that cannot be represented by classical geometry. Fractals are used especially in computer modeling of irregular patterns and structures in nature” (Hausdorff 1999). Many patterns once thought to be random now display fractal symmetry. For example, mountain ranges and coastlines, once thought to be random, are now showing fractal patterns. Figure 2 is an illustration of what a fractal may look like.

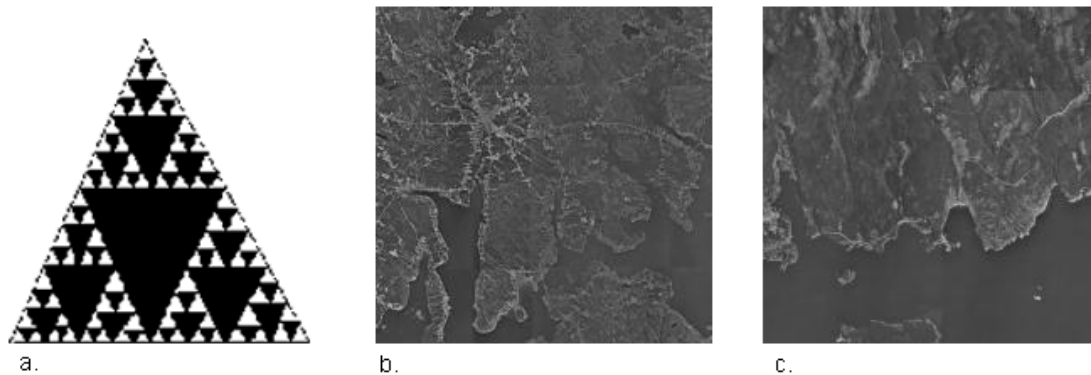

**Figure 2: (a) A Fractal of repeating triangles increasing in number and decreasing in size to form a triangle within a triangle and continuing smaller, (b) and (c) example of a repeating pattern in a shoreline.**

In the gait cycle the timing of every phase is important. “Measurement of the beginning and end of footfall is an essential component of gait analysis” (Hausdorff, 1994). Traditionally this is performed by using force plates; however one is not able to measure a high number of successive foot falls using this method. In order to do this a mobile system is needed that can accurately measure the time of each footfall. In 1994 Hausdorff et al. developed a foot switch system that consisted of two foot switches, one at the heel of the foot and one at the ball of the foot that were, “connected in parallel, and essentially act as one large sensor.” This setup senses when the foot makes contact with the ground and when the foot leaves the ground. In comparison to measurements made

using a force plate, the foot switch system proved to be a reliable system for capturing repeated gait cycles.

Using his foot switch system Hausdorff *et al* (Hausdorff 1995) published a paper that presented a new technique for analyzing gait patterns. Using a detrended fluctuation analysis (DFA), a modification of a root-mean square analysis, a scaling exponent  $\alpha$  is calculated. Long range correlations in the gait patterns were discovered and showed evidence of a fractal pattern.

In a detrended fluctuation analysis the scaling exponent ( $\alpha$ ) can be calculated in the following manner. The time series is first integrated where  $y(k)$  is the integrated time series and

$$y(k) = \sum_{i=1}^k [I(i) - I_{avg}] \quad (2-1)$$

$I(i)$  is the  $i$ th stride interval

$I_{avg}$  is the average stride interval

$k$  equals the total number of stride intervals

Next, the time series is divided into equal length data records ( $n$ ) and a best fit line is drawn for each record. Within each record a least squares line is drawn and the y-coordinate of the line is designated by  $y_n(k)$ . The average fluctuation of  $y(k)$  around the locally best-fit line for each block size can be calculated by:

$$F(n) = \sqrt{\frac{1}{N} \sum_{k=1}^N [y(k) - y_n(k)]^2} \quad (2-2)$$

This sequence is repeated for all  $n$ . Typical values for  $n$  are from 4 to  $(N/4)$ , where  $N$  is the total number of strides in the stride interval series. A log-log plot of  $F(n)$  vs.  $n$  is

created and the slope of the line is  $\alpha$  (Hausdorff 1995). Table 3 discusses the significance of each  $\alpha$  value.

$\alpha$ coefficient	significance
$0 < \alpha < 0.5$	Power-law anti-correlations
$\alpha = 0.5$	White noise
$0.5 < \alpha < 1$	Long range power-law correlations
$1 < \alpha < 1.5$	Correlations exist but are no longer of the power-law type
$\alpha = 1.5$	Brownian noise, the integration of white noise

**Table 3:  $\alpha$  coefficient and its significance**

Hausdorff (1995) demonstrated the existence of long term gait correlation in the following experiment. Referring to Figure 3, (A) was the original stride interval data recorded by the subject walking for nine minutes. After analyzing that time signal in (C) using DFA, the slope was calculated to be  $\alpha = 0.83$  which according to Table 3 displays long range power-law correlations. The time series (A) was then randomly shuffled to create time series (B). Analysis of the shuffled time series produces an  $\alpha = 0.50$ , white noise. These results confirmed that long term gait correlations do exist.

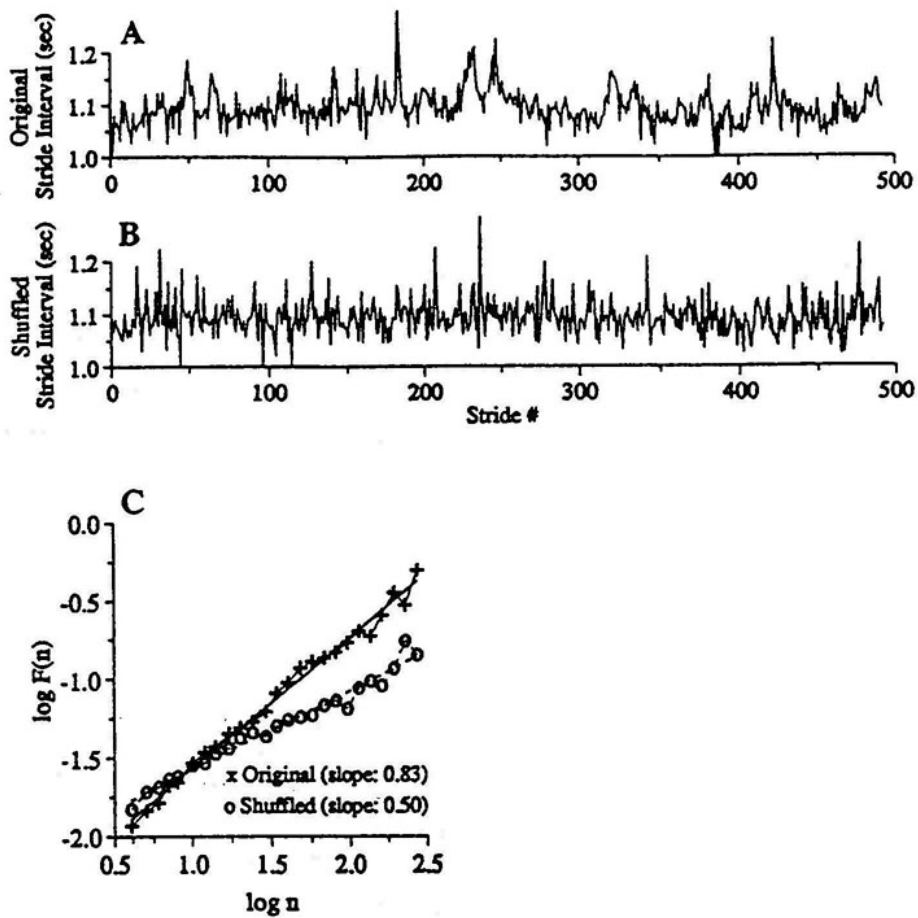

Figure 3: Fractal Gait Patterns (Hausdorff 1995), (A) original stride interval, (B) shuffled stride interval, (C) scaling exponents of original and shuffled stride intervals

Hausdorff has used the stride interval and the standard deviation of the stride interval to investigate two issues, the occurrence of falls in older adults and determining when the gait cycle becomes fully developed in children. In the study performed on older adults he discovered that the greater the gait variability (standard deviation of the stride interval) the greater the likelihood the person would fall. In his study conducted on children, he discovered that a child's gait does not become stable until the age of 11 – 14. This finding contradicts the idea that by approximately age 3 a child's gait has matured. "Thus, whereas visual observation might suggest that the stride dynamics of children are

not different from those of adults; quantitative measurement of gait dynamics indicates that stride-to-stride control of walking is not fully mature even at the age of 7-yr-old children” (Hausdorff 1999).

In 1998, West et al. performed a similar experiment using a different analysis technique, relative dispersion. Using the maximum extension of the knee to calculate the stride interval, the relative dispersion is calculated by dividing the standard deviation by the arithmetic mean. The data set was then broken down into  $n$  points and the relative dispersion is calculated for each size  $n$ . The number of points ( $n$ ) in each group was then doubled ( $n = 1, 2, 4, 8, 16 \dots$ ) and the relative dispersion is then calculated again. This process was repeated until there is little change observed in the relative dispersion. The fractal dimension can be calculated from the slope of the plot of the relative dispersion vs. the number of data points in each set. His results verified the finding of Hausdorff *et al.*: that long term gait correlations do exist. Furthermore, West states “The underlying complex structure in stride-interval variability is a manifestation of the control process determining human gait” (West 1998).

The major difference between the technique used by West and the technique used by Hausdorff is that West used the standard deviation divided by the mean value of the box looking at all of the points in the box at once. Whereas Hausdorff used the average subtracted from each individual point putting more of an emphasis on each data point. Both methods look at the entire data set, divide the individual points into segments and then look at larger and larger segments.

Taylor et al. (2001) continued the work of Hausdorff et al. by using the same detrended fluctuation analysis (DFA) as Hausdorff on the inter and intra-limb aspects of gait to predict falls in the elderly. This study investigated the minimum foot clearance

(MFC), both temporally and spatially, to determine how it relates to falls. “The MFC event is considered an important parameter in understanding falls, specifically falls resulting from a trip. The task of MFC is to avoid ground contact during the swing phase; hence, it is an important objective in the control of gait.” To record the data Taylor had the subject walk on a treadmill for thirty minutes with two cameras, on opposite sides of the treadmill, recording data at 50 Hz. Two LED’s were used to mark the heel and toe of the shoe. The data were then manually digitized and a software package was used to determine the temporal and spatial properties of the MFC. Once these data points were determined detrended fluctuation analysis was used to analyze the data for long range correlations. Five different parameters were evaluated: the time interval between each left foot MFC, the time interval between each right foot MFC, the height of each left foot MFC, the height of each right foot MFC, and the difference in height between the left and right foot MFC. Results showed both temporal and spatial parameters have an  $\alpha$  value between 0.5 and 1.0 (see Table 4). Thus it can be concluded these parameters do have long range power-law correlations (Table 3).

	Mean	$\pm$ SD	$\alpha$
Temporal Parameters			
L-L MFC time (s)	1.134	$\pm 0.016$	0.815
R-R MFC time (s)	1.134	$\pm 0.020$	0.800
Spatial Parameters			
L-L MFC (cm)	1.412	$\pm 0.199$	0.803
R-R MFC (cm)	2.518	$\pm 0.274$	0.972
L-R MFC (cm)	1.106	$\pm 0.351$	0.940

**Table 4: Inter and Intra-limb temporal and spatial parameters (Taylor, 2001).**

Comparing the data from the MFC spatial parameters an imbalance exists between the left foot and the right foot. However since the difference between the two

feet does exhibit long range correlations some type of a coordinating relationship is indicated. "... the MFC event is either dependent upon the contra-lateral limb (a localized coordinating relationship) or a higher order mechanism (a coordinating control center)."

Other studies have been performed using similar techniques to determine if gait patterns are affected by disturbances, such as disease, knee surgery, pace, and age. The conclusions of these studies have found that the greater the disturbances in their gait, the greater the breakdown in their gait patterns. Gait patterns break down with people suffering from diseases, those who have had surgery on their knees, get older and are forced to walk at a pace either faster or slower than their own pace.

The use of fractal techniques to analyze biological data is not a new concept. Goldberger et al. (2002) used fractal techniques to analyze human heart rate patterns to determine if there were alterations in the heart rhythm with disease and age. The results showed that a diseased human heart displays a breakdown of the fractal pattern when compared to a healthy human heart. The same result also occurs with aging. Fractal patterns were compared among subjects spanning age ranges of three decades, younger subjects displayed a higher correlation in their heart rate than the older subjects suggesting the fractal patterns of the human heart breakdown with age.

Peng et al. (2002) proceeded to use the same analysis technique to study human respiration. In this study, 20 young and 20 elderly people had their respiration rate monitored for 120 minutes. The respiration time intervals were then analyzed using the detrended fluctuation analysis. The study showed there was no significant difference in the scaling exponent  $\alpha$  for young men, young women, and elderly women,  $\alpha \sim 0.69$ . However, there was a significant difference for the scaling exponent in elderly men,  $\alpha = 0.60$ . This implies there is degradation of long range scaling patterns in elderly men.

With the discovery of fractal patterns in biological data more experiments are being performed to test for fractal patterns in other biological data. Evidence gives rise to the hypothesis that as fractal patterns break down in a person it gives indication of disease or disturbances in normal biological data.

### **Chapter 3: Methodology**

The goal of this thesis is to investigate the effects of knee pads on comfort and gait. This was accomplished by measuring the pressure exerted by the knee pad on the back and front of the knee during ascending and descending stairs, kneeling on their left and right knee followed by kneeling on both knees. Three force sensors attached to different locations on the knee, a knee goniometer attached to the left knee was used to measure knee angle, and a data logger recording at 30 Hz. were used to measure the pressure exerted by the knee pad on the knee.

In the second phase of this study the effect of wearing knee pads on long term gait correlations was analyzed by performing a fractal analysis on the stride interval for both the left and right foot. Foot switches, two for each foot, were taped to insoles and placed in their shoes, a knee goniometer was attached to their left knee, and a data logger recording at 30 Hz were used to measure the subjects' stride interval.

#### **Section 3.1: Development of the Data Acquisition System**

The first step in being able to record data was to build a data acquisition system that was capable of recording all of the necessary data at the desired settings while still being portable and affordable. While there were commercially available complete systems that were capable of performing most of the desired tasks, they were too expensive. Multiple approaches were investigated, from building a system from the ground up, purchasing a portable data logger, purchasing a data acquisition card for a portable computer (PDA), and purchasing a data acquisition card for a laptop computer. The decision was made to purchase a data acquisition (DAQ) card for a laptop computer along with separate sensors and then to build the required circuitry to allow the sensors and DAQ card to interface correctly. The interface circuits consisted of a power supply

for the sensor and an amplifier and/or a filter for the output of the sensor. Figure 4 gives a basic layout of the entire system.

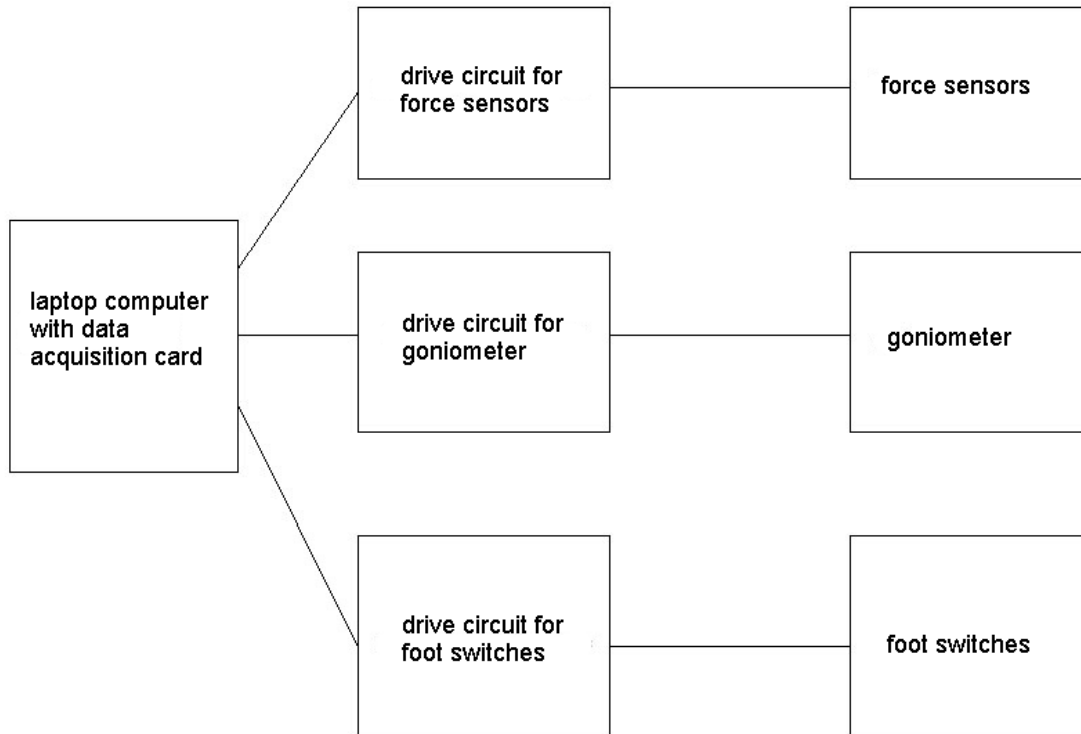

**Figure 4: Basic layout of the data acquisition system**

### **Section 3.1.1: Sensors**

Three types of sensors are required to conduct these studies: force sensors, knee goniometers and foot switches. All sensors deliver an analog signal (voltage) which is converted into a digital signal and recorded. The force sensor is a thin film piezo-resistor that is capable of measuring different forces and the output changes based on the applied force. Knee goniometers are devices that attach to the knees and are capable of measuring the angle of the knee through the use of a potentiometer. The foot switch is similar to the force sensor except it only outputs an on-off signal depending on if there is force being

applied to it. The data acquisition card is a portable device that converts the output voltage from the different sensors to a digital signal and then records it.

### Section 3.1.1.1: Force Sensors

Three force sensors were positioned on each knee. The first sensor was located on the posterior side of the knee approximately over the tendon (Figure 5b) and was intended to measure the pressure between the top strap of the knee pad and the tendon during normal use and flexion of the knee. The second sensor was located on the posterior side of the knee on the calf (Figure 5b) intended to measure the force between the bottom strap of the knee pad and the knee. The third force sensor was located on the anterior side of the knee at the base of the patella (Figure 5a) intended to measure the force on the knee by the knee pad during kneeling. All of the sensors were held in place with masking tape and by the knee pad.

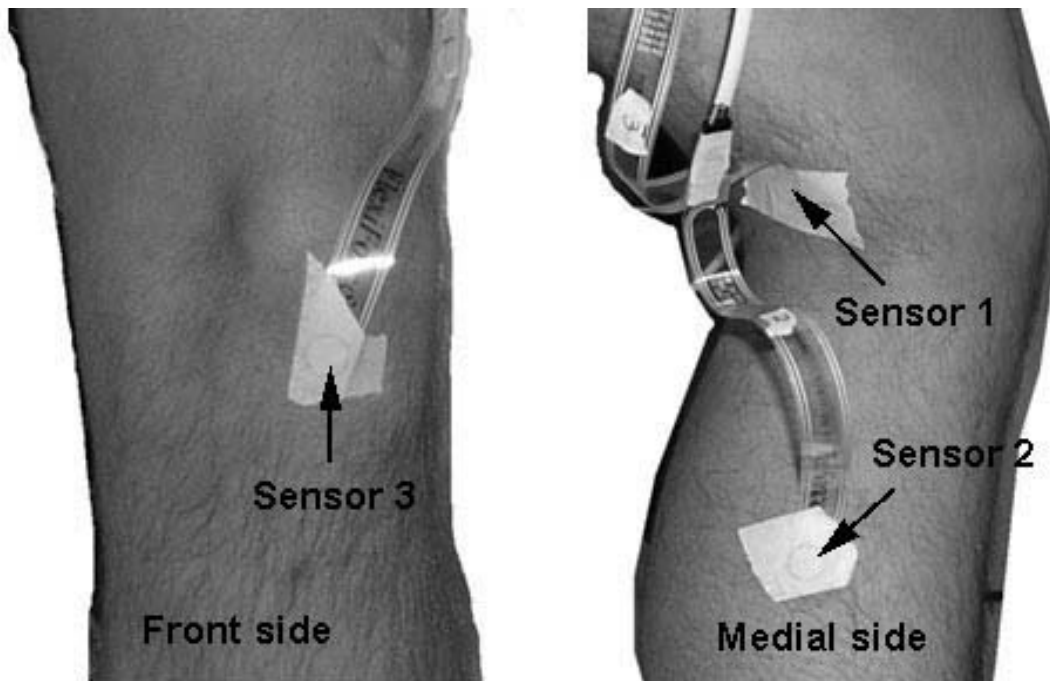

Figure 5: (a) Pressure sensor on anterior side of of the knee

(b) Pressure sensor on posterior side of the knee over tendons

The force sensor used is the FlexiForce<sup>®</sup> A101-25 force sensor produced by Teckscan (South Boston, MA). The sensor is 0.005 inches thick, 8 inches long, 0.55 inches wide and has an active sensing area of 0.375 inch diameter (0.11 square inches).

The sensor voltage output varies linearly with the applied load from 0 to 25lbs. Typical performance of the sensor is shown in Table 5.

Linearity (Error)	< ±5% (Line drawn from 0 to 50% load)
Repeatability	< ±2.5% of Full Scale (Conditioned Sensor, 80% of Full Force Applied)
Hysteresis	< 4.5 % of Full Scale (Conditioned Sensor, 80% of Full Force Applied)
Drift	< 3% / logarithmic time (Constant Load - 25 lb.)
Rise Time	< 20 μsec (Impact load – recorded on Oscilloscope)
Operating Temperature	15°F – 140°F (-9°C - 60°C)

**Table 5: Force Sensor Performance (www.tekscan.com)**

Prior to the attachment and use of the pressure sensors they first had to be conditioned and then calibrated. To condition the sensor, each sensor had to be loaded to 110% of its maximum load, in this case 27 lbs. To calibrate the sensors each sensor was loaded to 5 lbs. with calibrated weights and the voltage recorded for the different weights. It was found the behavior of the sensors did perform as specified by the manufacturer. However the output voltage being recorded by the DAQ card’s software amplified the signal by a power of 10 for easier analyzing. The calibration equations for the sensors appear in Appendix A.

**Section 3.1.1.1.1: Drive Circuit**

A simple circuit is used to power the pressure sensor and filter the signal coming from the sensor before it reached the data acquisition (DAQ) board (Figure 6). The circuit is powered by a 9 volt battery that leads into a LM7905 (-5V) voltage regulator to power the sensor. The output of the sensor then goes to pin 2 (for sensor 1) and pins 6 and 13 (for sensors 2 and 3 respectively) of a four channel operational amplifier (opamp) model LM348N. A 22kΩ resistor between pins 1 and 2 (6, 7 and 13, 14 respectively) was used for a feedback resistor. Before the output went to the DAQ board, the output, pin 1 (7 and 14) was connected in parallel to the reference ground by a 15kΩ resistor and 334μF capacitor to help filter the signal.

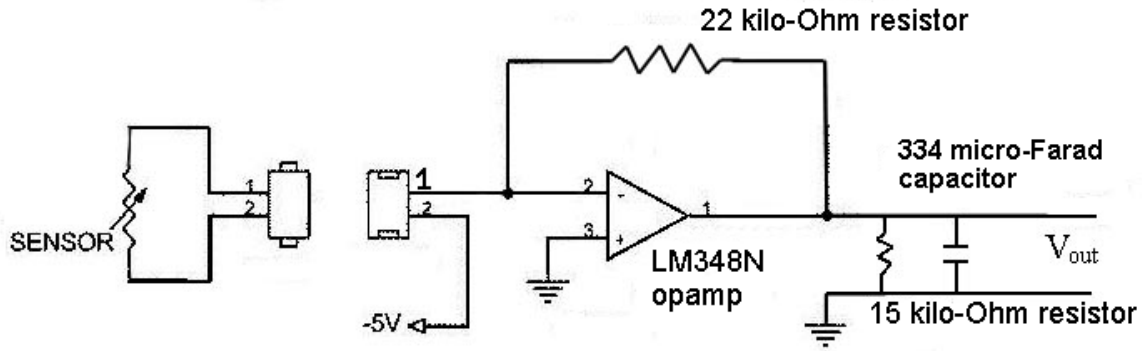

**Figure 6: Wiring diagram for pressure sensor**

The purpose of the opamp is to boost the signal from the sensor. An additional function of the opamp is to control the sensitivity of the sensor by changing the resistance of the feedback resistor. For the purpose of this thesis a 22 k $\Omega$  resistor was used in the drive circuit to achieve higher sensitivity in the lower sensing range of the sensor. However the opamp suggested by Tekscan<sup>®</sup>, MC34074, was not used due to cross talk between the channels; a LM348N opamp was used instead.

### **Section 3.1.1.2: Knee Goniometers**

The knee goniometer used in this thesis was Model SG180 manufactured by Biometrics Ltd. (Cwmfelinfach, Gwent NP11 7HZ) of the UK. It is distributed in the US by Motion Lab Systems, Inc (Baton Rouge, LA). The goniometer is a twin axis goniometer measuring both flexion and torsion. It is specifically designed for use on the knee. The specifications for the goniometer appear in Table 6.

Weight	19 grams
Measuring range	$\pm 150^\circ$
Crosstalk	$\leq \pm 5^\circ$
Transducer type	Strain gauge
Life	300,000 cycles minimum
Accuracy	$\pm 2^\circ$ measures over $90^\circ$ from neutral position
Repeatability	Better than $\pm 1^\circ$

**Table 6: Specifications of Motion Lab Systems SB180 goniometer**

The goniometer was attached to the left knee of the subject using masking tape. The goniometer was beneath the knee pad if the knee pad was being used. The bottom part of the goniometer was attached just below the knee, aligned between the knee joint and the ankle. The top part was aligned along the thigh between the knee joint and the hip. This was done to achieve the best possible measurement of the angle of the knee, however this method of attachment does leave room for some misalignment error. Since the goal of the project is to measure pressure as a function of knee angle the absolute angle is not required and the relative angle can be used.

#### **Section 3.1.1.2.1: Goniometer Drive Circuit**

Only the flexion of the knee is being measured (not torsion) and thus only the green plug of the goniometer was used. The B1500 Interconnecting lead was used to hook the goniometer up to third party measuring equipment. The open end of the lead had four different colored wires; red, yellow, green and blue. The green and red wires were used for the supply voltage and the blue and yellow wires were used to measure the output voltage. A 9V battery connected to a variable output voltage regulator was used to power the goniometer. The configuration of the voltage regulator allowed the goniometer to be powered at 1.8 volts which was below the maximum permissible supply voltage of

2V. The output from the goniometer when powered at 2V and bent to an angle of  $100^{\circ}$  is 0.002V. This voltage is in the same range as noise picked up by the data acquisition card, thus the output signal was amplified using a MC34074 opamp with an equivalent feedback resistance of  $5.5\text{M}\Omega$  with an approximate gain of 1000 (Figure 7). This signal was then recorded by the DAQ board.

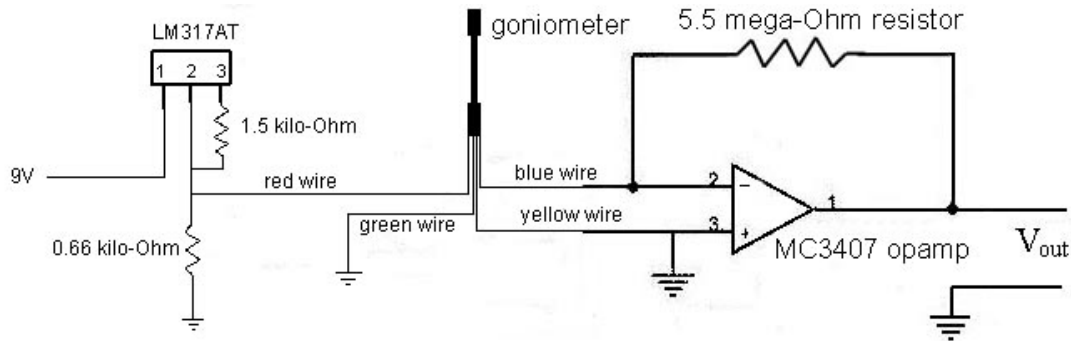

**Figure 7: Wiring diagram for Goniometer**

### **Section 3.1.1.3: Foot Switches**

The foot switches were model A-153 Standard foot switch produced by Motion Lab Systems (Baton Rouge, LA). The switch is 1mm thick and has a sensing area of 15mm with a 100mm flexible tail. As force is applied to the sensor the resistance of the sensor drops and it is ON. When the load is removed the resistance increases and the sensor is OFF. During the gait cycle as a person's heel strikes the ground the force applied to the foot switch turns it ON. Since there are two foot switches in each shoe wired in parallel the switch will not turn off until pressure on both of the switches is released. This happens as the person lifts their foot of the ground (toe off). The properties of the foot switch are shown in Table 7.

Repeatability	Cycle to Cycle $\pm 5\%$
Force Action Point	10g 10 30g
Maximum Applied Pressure	Approximately 500psi [34kg/cm <sup>2</sup> ]
Device Rise Time	1 mS [mechanical]
Lifetime	10,000 actuations
Sensitivity to Noise / Vibration	Not significantly affected
EMI	Intrinsically insensitive to EMI and does not generate EMI

**Table 7: Foot Switch Properties**

In order to prevent the foot switch from sliding around inside the subjects' shoe, the foot switches were attached to boot inserts and inserted into the person's footwear. This allowed proper placement of the switch and insures no movement of the switch during testing. Black electrical tape was used to attach the foot switch to the boot insert. Two foot switches were attached to each insert, one at the heel of the foot to detect the heel strike, and one at the ball of the foot to detect liftoff. With the two sensors wired in parallel the stance time for the foot can be recorded.

### Section 3.1.1.3.1: Foot Switch Drive Circuit

The foot switches were powered by a 9V battery that was connected to a LM340 5V regulator. The circuit used was a simple voltage divider. The footswitch was wired in series with a 10K $\Omega$  resistor, the output voltage was measured across the footswitch (Figure 8).

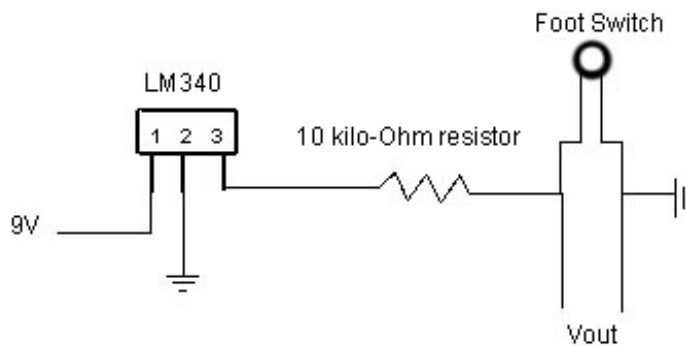

**Figure 8: Wiring diagram for foot switch**

When the footswitch was open (no load) its resistance went to infinity and  $V_{out}$  was 1.9V.

When the switch was closed (load) the resistance dropped to 0 and the output voltage went to 4.4V.

### **Section 3.2: Data Acquisition**

For the comfort analysis the signals from the pressure sensors and knee goniometer were recorded. The pressure sensors were connected to channels 0, 1 and 2 of the data acquisition system, and the goniometer was connected to channel 4. In the gait analysis the signals from the goniometer and foot switches were recorded. The goniometer was connected to channel 4 and the foot switches were connected to channels 6 and 7 of the data acquisition system.

The data acquisition system used for this project was the NTBK2 system (SuperLogics, Waltham, MA). The system consisted of the DAQP-16 data acquisition card, a connector block used to accept field wiring, and the Winview software package to run the card. The card was designed to operate out of a PCMCIA card socket of a Windows based laptop computer. The card supported Microsoft C/C++, Visual Basic and Delphi for programming languages in addition to TestPoint, DasyLab and Lab View application development software. The included Winview software was Windows based for easy operation. The features of the card include:

- 100 kilo-samples/sec sampling, 16-bit analog input resolution
- 16 single-ended or eight differential analog inputs
- Programmable gain of 1,2,4,8
- Programmable channel scanning and gain selection for each channel, up to 256 channels
- 24-bit pacer clock with variable prescalers and external clock source

- Eight digital I/O channels

For this project six differential analog inputs were used at a sampling rate of 30Hz. A sampling rate of 200Hz was initially intended but due to a problem that will be discussed in Section 3.4 and 5.1.3, a sampling rate of 30Hz was chosen.

### **Section 3.3: Comfort Analysis**

This test consisted of three phases; attaching the sensors, mounting the knee pads, and connecting the sensors to the DAQ card. Prior to the beginning of the tests the subject was asked to either wear shorts or to wear a pair of provided shorts. This allowed for easier attachment of the sensors and the knee pads and to ensure once the knee pad was put on it would not move with the movement of their pants or BDU's, also it eliminated the need to run wires inside of the person's pants from the sensors to the computer.

The procedure for attaching the knee pads is as follows; the subject first held the knee pad up to their knee so the sensors could be positioned correctly. After the sensors were attached the person put the knee pad as they would for normal use making sure not to detach any of the pressure sensors. After the straps of the knee pad were fastened to the subject's desired tension the person performed any minor adjustments to the knee pad they felt necessary to make it fit correctly for them. It should be noted that the top strap of the knee pad was made out of an elastic material while the bottom strap was made out of a webbed material.

The person then spent three to seven minutes walking around adjusting to the knee pads. After the adjustment time was over, re-adjustments to the kneepads were made as needed and the DAQ card began recording four channels at 30 Hz. This

sampling rate was chosen because it was fast enough to record the desired data, a 3 second kneeling time giving around 90 samples, but slow enough so that it would not create a huge data file. Unlike the gait experiment noise in the signal from the sensors was not an issue. The person was then asked to perform the tasks listed in Table 8. While the person was performing the tasks the computer was carried by the administrator of the tests in such a manner so the person did not have to worry about the computer or the wires attached to the sensors. Although these tasks are not Individual Movement Techniques (IMTs) and not actual combat situations they were sufficient to measure the pressures exerted by the kneepads on the knees under a variety of situations. These tasks were reviewed by Dr. Haselquist at the Natick Soldier Center and deemed to be a reasonable substitution for actual IMT's. Actual IMT's include, but are not limited to, crawling on hands and knees, taking a knee while running and other rigorous activities. These tasks were chosen instead of IMT's because they presented less risk of injury to the test subjects than actual IMT's. Since the project involved human test subjects approval had to be gained by the institutional review board. IRB approval would have been more difficult to obtain if actual IMT's had been used. Furthermore, the wires attaching the sensors to the computer could have been pulled apart during actual IMT's.

Task number	Task
1	Ascending stairs
2	Descending stairs
3	Kneeling on left knee
4	Kneeling on right knee
5	Kneeling on both knees

**Table 8: Functional Tasks**

Description of tasks:

Ascending stairs – the person climbed the six stairs located in the basement of Higgins Labs at a slow to moderate pace using the handrail if necessary stepping off with their left foot first.

Descending stairs – the person descended the six stairs located in the basement of Higgins Labs at a slow to moderate pace using the handrail if necessary stepping off with their left foot first.

Kneeling on left knee – the person started with both of their feet together, then took a small step forward with their right leg and proceeded to a kneeling position on their left knee at a slow rate. They held this position for two seconds, stood back up and finished with their feet next to each other. A hand rail was next to them to grab onto if needed.

This process was repeated two more times.

Kneeling on right knee – the person started with both of their feet together, then took a small step forward with their left leg and proceeded to a kneeling position on their right knee at a slow rate. They held this position for two seconds, stood back up and finished with their feet next to each other. A hand rail was next to them to grab onto if needed.

This process was repeated two more times.

Kneeling on both knees – two different methods were used by the people that participated in the study, the method they used depended on the person. The first method was they started with both of their feet together, then took a small step forward with either their left or right leg and proceeded to a kneeling position on their other knee at a slow rate.

Next they brought their other knee down to a kneeling position next and held this position for two seconds then stood up with their feet next to each other using the hand rail next to them for the entire process if desired. Or the person went down onto both knees at the

same time holding onto the hand rail next to them for both balance and support. This process was repeated two more times.

After these tasks were completed the data logger was stopped. At the end of this cycle the knee pads and sensors were removed and properly stored. Since there was a live readout of the data being recorded if the process had to be repeated it was known immediately during testing. After data were recorded from both this procedure and the gait analysis the person was asked to fill out a survey evaluating the comfort and performance of the knee pads (Figure 9).

**Follow up Survey:**

1. Did the kneepads stay properly attached to your knees during movement?

YES NO

If NO, please explain.

2. Did the kneepad restrict your range of motion?

YES NO

If YES, please explain.

3. Did the kneepad restrict your circulation?

YES NO

If YES, please explain.

4. Did the kneepad fit properly?

YES NO

If NO, please explain.

5. Using the scale provided, please rate the kneepad for the following criteria. Circle ONE number for each. If you can not answer for a particular item, circle "N/A."

	UNCOMFORTABLE	MODERATE	NEITHER	MODERATE	COMFORTABLE	
	1	2	3	4	5	
a. Comfort when kneeling	N/A	1	2	3	4	5
b. Comfort when prone	N/A	1	2	3	4	5
c. Comfort when walking	N/A	1	2	3	4	5
d. Comfort when standing	N/A	1	2	3	4	5
e. Comfort overall	N/A	1	2	3	4	5

Comments?

6. Did you experience any binding or discomfort from the kneepad?

YES NO

If YES, please indicate where.



Figure 9: Follow up survey asked of participants.

### **Section 3.4: Gait Analysis**

The testing procedure for measuring gait consisted of four different phases; attaching the sensors and knee pads, walking with the knee pads, walking without the knee pads and evaluation of knee pads and sensors. Every person participating in this procedure wore their own shorts and footwear to ensure proper fit and to not have to worry about obtaining the correct size boot from the US Army for every subject and giving them ample time to break the boots in. The data recorder was carried by the person administering the test so no extra loads were carried by the subject.

Before the person arrived the foot switches were attached to the insoles of boots using the method described in section 3.1.3. The size of the insole used was not a factor in fitting the insole into the persons shoe. The subject was also asked to wear shorts to make it easier to attach the knee goniometer. A few of the subjects did choose to wear

wind pants over their shorts due to weather conditions. The few subjects that chose to do this wore the knee pads underneath the wind pants and wore the wind pants for both trials with and without the knee pads. Upon arrival of the subject, the goniometer was attached to their left knee to give a positive voltage output from the goniometer. The person then put the knee pads on, tightening the straps to a self selected tension so that the knee pad would not slip down or be tight and cut off circulation. The knee goniometer and foot switches were then attached to the data logger which was set to record three channels at 30Hz. Care was taken to keep the wires as controlled as possible by fastening them to a belt loop with a carabiner to minimize the threat of tripping. The sampling rate of 30 Hz was chosen to try to minimize the error in recording the stride interval. A faster sampling rate was initially going to be used but due to unknown problems the signal at higher frequencies was too noisy and could not be used. After the data recording was started, the person walked three laps on lane 4 of a 400 meter track. Once the person completed the 3 laps the data recording was stopped, and the knee pads were removed. The person then completed another three laps in the same lane and direction as before without the knee pads. After the test was completed the sensors, knee pads and data logger were removed and properly stored. After data were recorded from both this procedure and the comfort analysis the person was asked to fill out a survey (Figure 9) evaluating the comfort and performance of the knee pads.

### **Section 3.5: Subjects Used**

For this study the sample size was 6 people. Each person that participated in the study met the following requirements:

1. Be between the ages of 18 and 25.
2. No obvious physical limitations that would prevent service in the US Army.
3. Be able to jog for 10 minutes at a self selected pace.
4. Not have any obvious gait abnormalities.
5. Have signed a written consent form. (attached in Appendix)

### **Section 3.6: Data Processing**

The gait analysis required the most processing of the two different types of data records. After the signal was recorded it was filtered and then the stride interval time signal was created. After the stride interval time signal was created that signal had to be filtered before the DFA could be performed. Once the DFA was performed and the  $\alpha$  coefficients calculated, a Wilcoxon signed – ranked test, a two tailed paired t-test and correlation coefficient tests were performed comparing data from with and without knee pads. The same tests were also performed comparing the left foot and right foot.

To perform the force analysis the data was first filtered, then the calibration equations for each sensor were applied to the data set for the appropriate sensor. From these data the maximum pressure for each task was obtained. Graphs were then created of the normalized maximum pressures (using task 3, sensor 3) and the absolute maximum pressures for the different tasks, sensors and subjects.

#### **Section 3.6.1: Gait Analysis**

The recorded data were imported into Matlab for analysis. A 16-bit DAQ card was used and the voltages were recorded with a tenth of a volt accuracy. However for

stride interval only a binary signal was required to analyze the data. The first step in analyzing the data from the foot sensors was to run an averaging filter on the data to help eliminate any spikes, such as false heel strikes, in the data. The averaging filter used for this task was  $(n_{-1} + n + n_{+1})/3$ . This filter was run twice on the data set to help eliminate larger errors in the data. A threshold voltage was then set, any value below that voltage was set to 0, and any value above that voltage was set to 4V. The value of the threshold voltage varied from 0.3 to 0.6 volts from data set to data set. From the filtered data the stride interval as a function of stride number was generated. Before the DFA was performed, the time series was visually inspected for assumed errors in the data. If an assumed error was found the necessary corrections were made to the data. If a stride interval was too long ( $t > 1.3$  seconds), based on the average stride interval, it was deleted. If the interval was too short ( $t < 0.8$  seconds) the stride intervals before and after were examined and if there were two shorter stride intervals next to each other then they were added together. Figure 10 shows an example time signal and how the time series is adjusted. If two time values next to each other were less than the approximate mean value of the dataset, then the points were added together. In a few cases some points were deleted because the time value of the stride interval was twice the value of its neighboring points.

Initial Time Signal	Adjusted Time Signal
1.167	1.167
1.099	1.099
1.134	1.134
1.2	1.2
<b>0.467</b>	<b>1.133</b>
<b>0.666</b>	
1.067	1.067
<b>0.534</b>	<b>1.2</b>
<b>0.666</b>	
1.133	1.133
1.133	1.133
1.101	1.101
1.166	1.166
1.1	1.1
1.1	1.1
1.134	1.134
1.133	1.133
1.133	1.133
1.167	1.167
1.167	1.167
1.1	1.1
1.199	1.199
1.168	1.168
1.166	1.166
1.1	1.1
1.1	1.1
<b>0.767</b>	<b>1.2</b>
<b>0.433</b>	
<b>0.467</b>	<b>1.133</b>
<b>0.666</b>	
1.167	1.167
1.167	1.167
1.166	1.166
1.167	1.167

**Figure 10: Adjusted Time Series depicting the addition of two sequential stride intervals of short duration to form one stride interval.**

The time series was then analyzed using the DFA technique outlined in section 2.1.2 to determine if there are any long term correlations in the data. The scaling exponent ( $\alpha$ ) was calculated and used to give insight into fractal patterns that occur in gait. To perform this analysis the filtered time signal was saved as a text document and

then analyzed using the DFA program that Hausdorff used and made available for download on Physionet (<http://www.physionet.org/physiotools/dfa/>). The output of this program generated two text columns that contained  $\log n$  and  $\log F(n)$  that were then copied into Microsoft Excel where an x-y scatter plot was created of the points. From these points a trend line was created and the linear slope of that line was the scaling exponent ( $\alpha$ ). Further details of the data analysis appear in Appendix H.

A DFA analysis was also performed on the signals obtained from the goniometer. The time signal was filtered the same way as the signal from the foot switches; however instead of using a threshold voltage to convert the signal into a binary signal a threshold voltage was set to filter out lower voltages so only voltages representing maximum knee flexion remained. The local maxima of the time signal were marked using a built-in command in Matlab. The DFA was then performed on the time signal created by the local maxima. It should be noted that the foot signal is measuring the stride interval from heel strike to heel strike and the goniometer signal is measuring stride interval from maximum flexion to maximum flexion of the knee.

### **Section 3.6.2: Comfort Analysis**

Once the data file was downloaded from the data logger to the computer, the data were converted into an Excel file. In Excel, the data were converted from a voltage signal to a pressure measurement as a function of time. The data were then run through an averaging filter  $((n_{-1} + n + n_{+1})/3)$  to smooth the data. Graphs were generated for the knee angle and pressures recorded by the sensors (Appendix D).

## Chapter 4: Results

Each subject walked  $\frac{3}{4}$  of a mile at a rate of 3 mph, first wearing knee pads then without knee pads. The stride interval time series was recorded and a DFA was performed on it. Correlation ( $\alpha$ ) coefficients were calculated for both the left and right foot for both trials with and without kneepads. Comparisons were made between runs with knee pads and runs without knee pads as well as comparisons between the left foot and the right foot.

In addition each subject was also asked to complete five different functional tasks while wearing knee pads. The average maximum pressure for each task was then tabulated and graphs of the absolute and normalized pressures were generated to compare measurements between the different subjects, tasks and sensor locations.

### Section 4.1: Gait analysis

Figure 11 shows a time series obtained with the kneepad from the goniometer. The stride number of the subject is plotted on the x-axis where the time for each step, also know as the stride interval, is plotted on the y-axis. The stride interval is fairly consistent and shows little variation in the persons' stride. In this data series the average stride interval is 1.24 seconds with a standard deviation of 0.05.

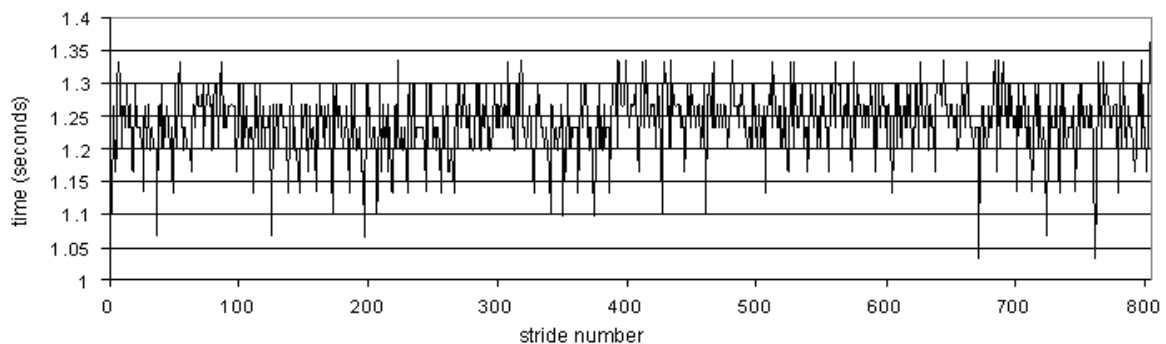

Figure 11: Stride Interval time series

The DFA is then performed on this data series and Figure 12 is generated. The alpha coefficient is the slope of the linear regression line. The alpha value for this data series is 0.60 which according to Table 3 exhibits long range power-law correlation.

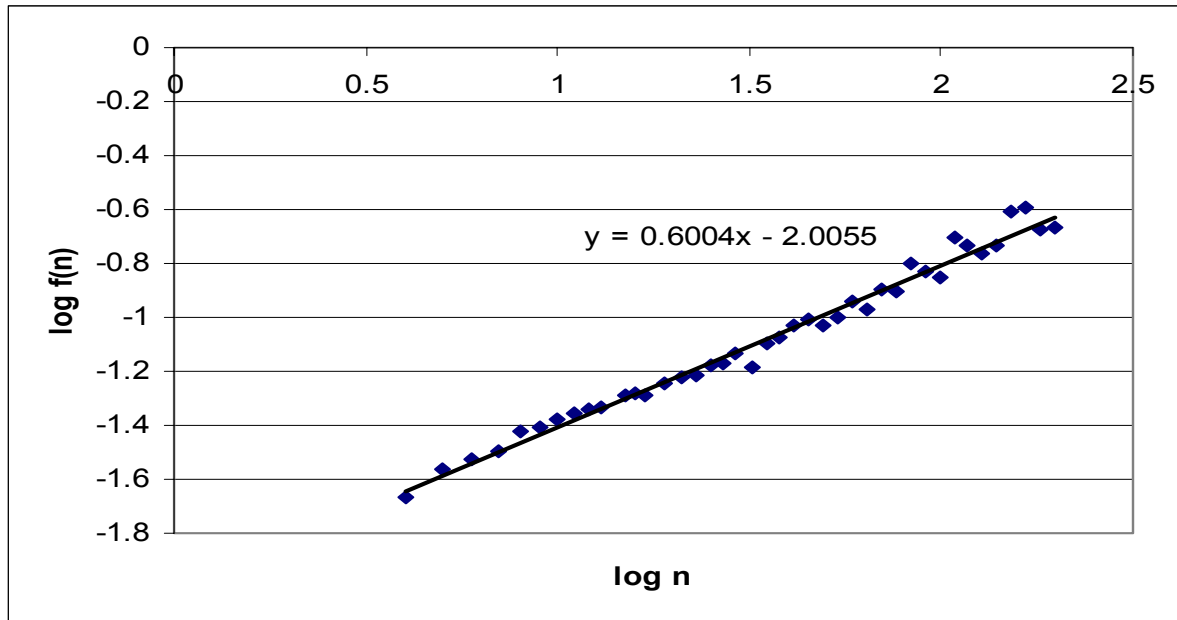

Figure 12: Detrended Fluctuation Analysis of time series

Table 9 shows the  $\alpha$  coefficient for the stride interval for the different subjects for the left foot, right foot and knee goniometer. For the  $\alpha$  values obtained it can be seen that 80% of the values exhibit long range power-law correlations ( $0.5 < \alpha < 1$ ), while the other 20% exhibit power-law anti-correlations ( $\alpha < 0.5$ ). The  $R^2$  values indicate how well the data represent a straight line. Goniometer information is missing for subjects 4, 5 and 6 due to sensor malfunction that was not realized until the data were being analyzed. Had the sensor been working correctly it would have given a better indication for comparisons of with to without knee pads.

subject	Left Foot				Right Foot				Goniometer (Left Knee)			
	w/ knee pads		w/o knee pads		w/ knee pads		w/o knee pads		w/ knee pads		w/o knee pads	
	$\alpha$	R <sup>2</sup>	$\alpha$	R <sup>2</sup>	$\alpha$	R <sup>2</sup>	$\alpha$	R <sup>2</sup>	$\alpha$	R <sup>2</sup>	$\alpha$	R <sup>2</sup>
1	0.56	0.99	0.55	0.98	0.63	0.96	0.5	0.92	0.5	0.88	0.46	0.92
2	0.72	0.96	0.7	0.97	0.6	0.96	0.65	0.97	0.53	0.95	0.55	0.93
3	0.58	0.98	0.53	0.98	0.72	0.98	0.6	0.98	0.4	0.93	0.39	0.97
4	0.56	0.94	0.56	0.92	0.57	0.96	0.61	0.93	n/a	n/a	n/a	n/a
5	0.44	0.97	0.43	0.99	0.69	0.95	0.39	0.98	n/a	n/a	n/a	n/a
6	0.71	0.99	0.71	0.97	0.53	0.97	0.67	0.94	n/a	n/a	n/a	n/a

**Table 9:  $\alpha$  coefficient and R<sup>2</sup> values for multiple subjects. n/a – not available**

To verify that these results are not random two different sets of data from subject 2, left foot with knee pads ( $\alpha = 0.72$ ) and left knee with knee pads ( $\alpha = 0.53$ ), were shuffled and the alpha value re-calculated for the random data sets. The results of this were for the left foot with knee pads  $\alpha = 0.5$  and for the left knee with knee pads  $\alpha = 0.49$ . These results verify that the alpha values obtained were not a coincidence but a representation of that persons stride interval.

To test the hypothesis that knee pads did not significantly alter gait (null hypothesis), a Wilcoxon signed-rank test was performed on the alpha coefficient comparing the left foot with knee pads to left foot without knee pads, right foot with knee pads to right foot without knee pads, and both feet and goniometer with knee pads to without kneepads. At a level of significance of 5% the null hypothesis proved to be correct in all three situations (Table 10). The Wilcoxon signed-rank test was also performed comparing the left foot to the right foot first with knee pads, then without knee pads. The results of this test indicate the null hypothesis should be accepted ( $P < 0.05$ ), no significance was found between the left foot and the right foot in all three situations (Table 11).

Hypothesis: Knee pads do not effect Stride Interval

P(0.05) < 1.782		P(0.05) < 1.704
left foot	right foot	Pooled data
P = 0.524	P = 0.524	P = 0.000

**Table 10: Wilcoxon signed-rank test to test for knee pads altering the stride interval**

Hypothesis: There is no difference in stride interval between legs

P(0.05) < 1.782		P(0.05) < 1.726
with	without	Pooled data
P = 0.524	P = 0.524	P = 0.078

**Table 11: Wilcoxon signed-rank test to test for variations in stride interval from left to right legs**

The results of these tests are also verified by other statistical tests. A two-tailed paired t-test was used to test the probability that the two sets of data came from the same source. A correlation coefficient was used to test the strength of the linear relationship between the two sets of data (Table 12), with knee pads to without knee pads and Table 13, left foot to right foot. A value of 1 represents a direct correlation, where -1 represents a negative correlation and 0 is no correlation. Squaring the correlation coefficient and multiplying by 100 gives the percent of variation of one data set is accounted for by a linear relationship with the other data set.

	left foot	right foot	left knee	Pooled data
two-tailed paired t-test (p)	0.08	0.47	0.62	0.27
Correlation coefficient (r)	0.99	-0.61	0.93	0.53

**Table 12: Comparison of the stride interval with knee pads to without knee pads**

	With knee pads	Without knee pads	Pooled data
two-tailed paired t-test (p)	0.68	0.78	0.80
Correlation coefficient (r)	-0.63	0.87	-0.59

**Table 13: Comparison of the stride interval of left foot to right foot**

The results from the gait analysis show no significant differences in stride interval between wearing knee pads and not wearing knee pads over the entire sample. Individual variations between tests with knee pads and tests without knee pads do exist but were not significant. Variations from left foot to right foot also exist, but were not significant.

## Section 4.2 Pressure Measurement

Results from the pressure sensor show significant increases in pressure on the knee from sensors one, on the back side of the knee underneath the strap and three, on the front of the knee at the bottom of the patella, (Figure 13).

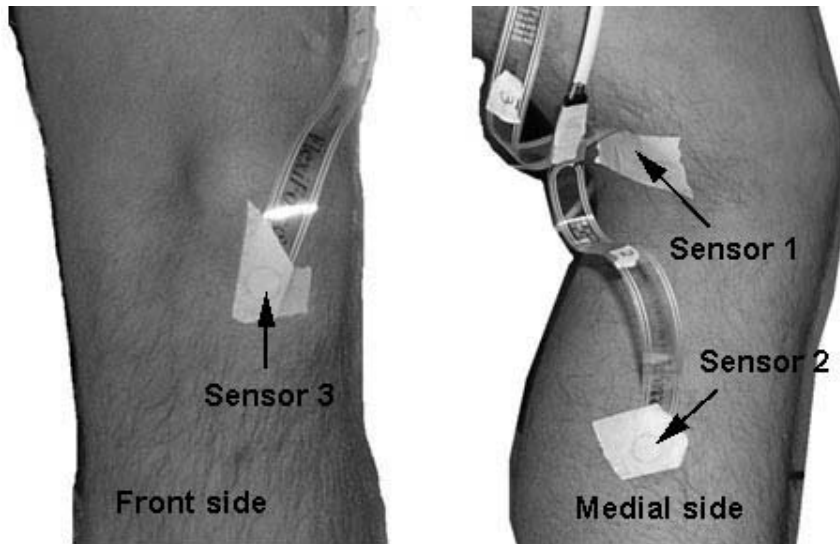

**Figure 13: Location of Sensors 1, 2 and 3**

No notable forces were measured from the second sensor on the back of the calf. In Figure 14 the knee angle and pressure recorded for the sensors are shown. The results are from subject 6 and vary slightly from the other subjects. The results from the other subjects are displayed in appendix D. Five different tasks were performed by the subjects, climbing up stairs, climbing down stairs, going down to left knee, going down to right knee and going down to both knees. The greatest pressure measured from the sensors was from pressure sensor 3 located on the patella. The greatest pressures were measured when the subject was kneeling on one or both knees. Significant pressures were also measured during stair climbing when the knee was at maximum flexion. Sensor one displayed increases in pressures when the knee was bending and when the hamstrings were being used the most.

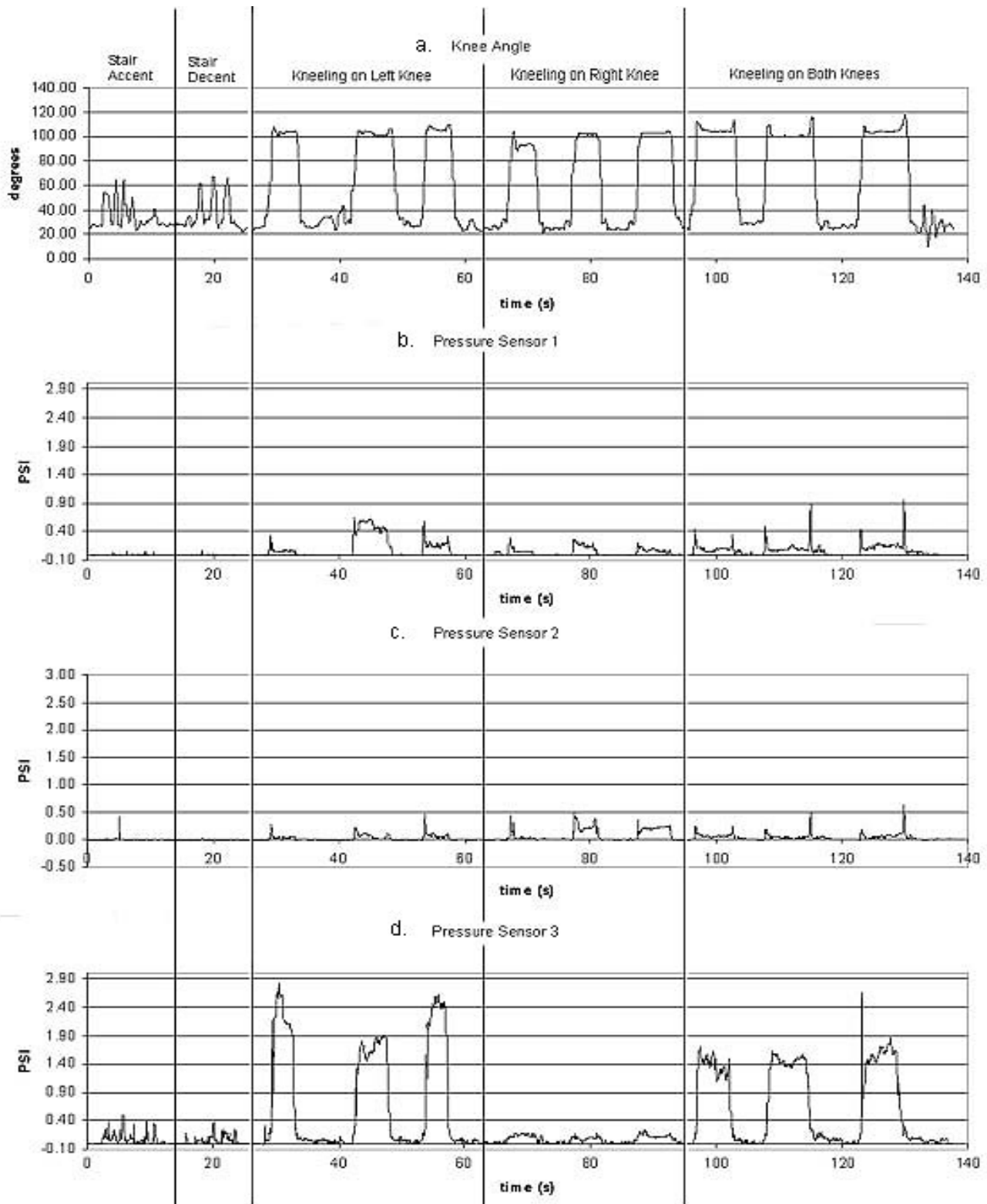

**Figure 14: Typical Knee Angles and Pressures beneath kneepad while undertaking various activities (Subject 6), (a) Knee angle, (b) Pressure Sensor 1, (c) Pressure Sensor 2, (d) Pressure Sensor 3**

The pressure values were normalized using the values from sensor 3 located on the patella of the knee, task 3, kneeling on left knee. This was the highest pressure value recorded for subjects 1, 2, 4, 5 and 6. The highest pressure value recorded for subject 3 was sensor 3, task 5 kneeling on both knees; this value was 172% of the value recorded during task 3.

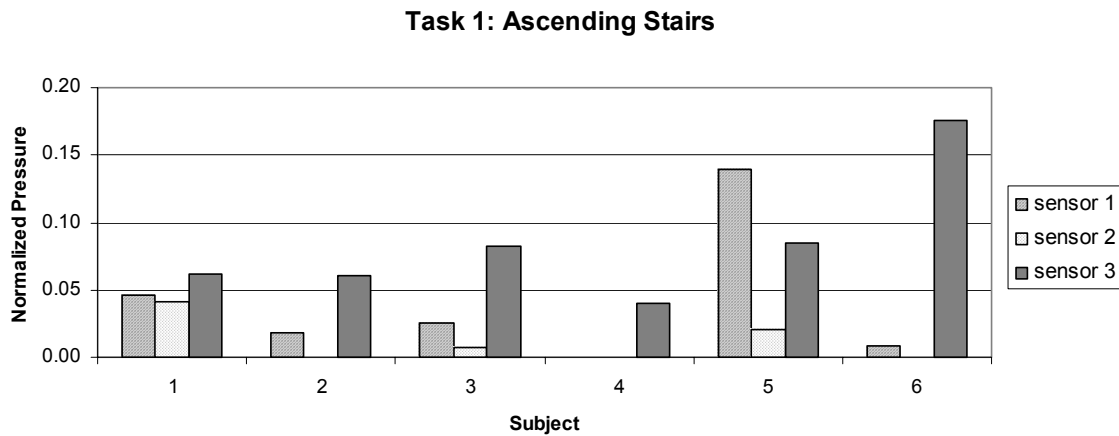

**Figure 15: Normalized values for Task 1, ascending stairs**

In ascending stairs the pressure readings for the first subject are similar for all of the sensors which is not in agreement with the rest of the subjects. The rest of the subjects display higher values for sensors 1 and 3; typically sensor 3 had the highest values except for subject 5. Sensor 2 did not record any pressures, measured 0, for subjects 2, 4, and 6.

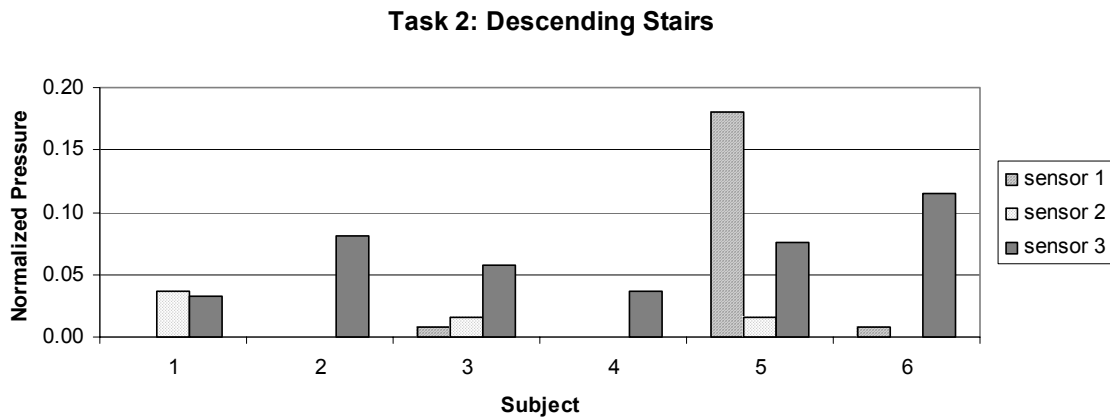

**Figure 16: Normalized values for Task 2, descending stairs**

In descending stairs the results are not consistent from subject to subject. Sensor 1 doesn't record anything for subjects 1, 2 and 4, but in subject 5 it is the highest value. Sensor 3 remains fairly consistent for the different subjects as does sensor 2 when it records any pressures.

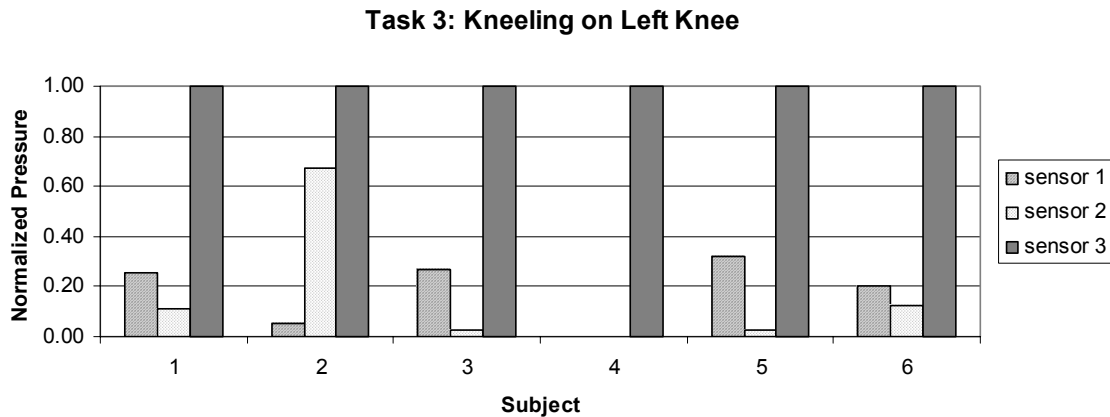

**Figure 17: Normalized values for Task 3, kneeling on left knee**

Sensor 3 for kneeling on left knee was used as the reference for normalizing the pressure readings to help rule out any influence the weight of the subject may have had so values could be analyzed without the effects of weight. As a result all the normalized values for sensor 3 in this task are the same. The readings from sensor 1 are similar for the different subjects with the exception of subject 4 where only sensor 3 recorded any pressures. Subject 2 did have a 60% higher pressure value for sensor 2 than the rest of the subjects.

#### Task 4: Kneeling on Right Knee

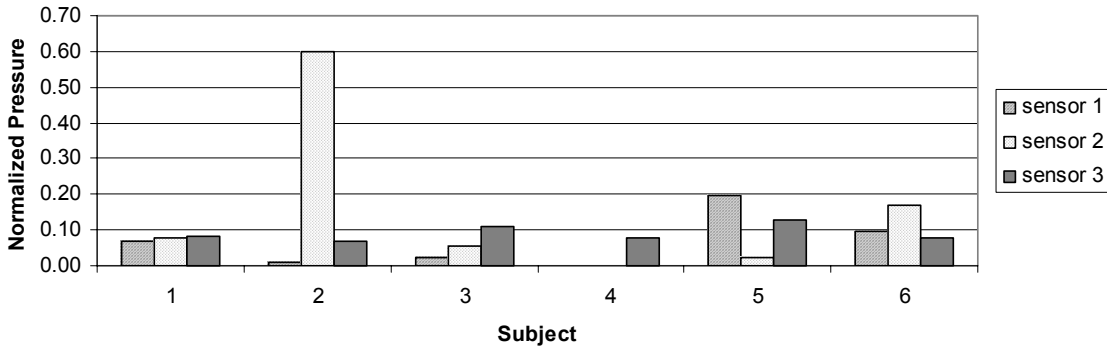

Figure 18: Normalized values for Task 4, kneeling on right knee

When kneeling on right knee, all of the normalized pressure readings were less than 17% with the exception of sensor 2 for subject 2.

#### Task 5: Kneeling on Both Knees

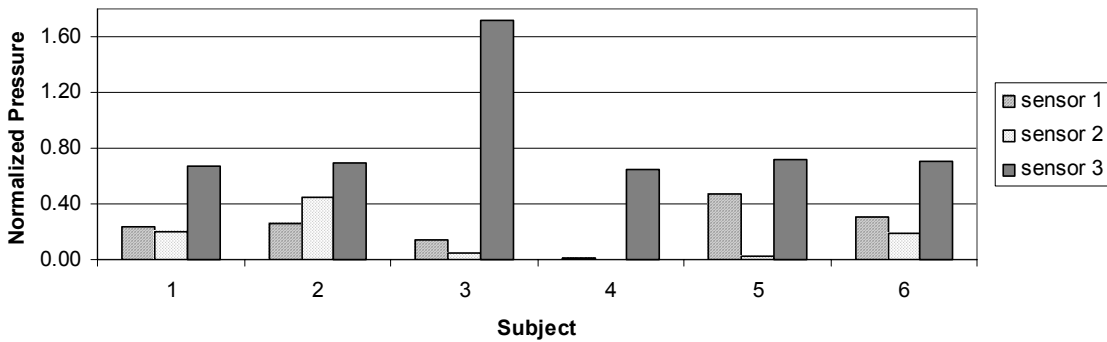

Figure 19: Normalized values for Task 5, kneeling on both knees

When kneeling on both knees subject 3, sensor 3 was the only sensor that was above the baseline value. The values for the other subjects were very similar.

After normalizing the data to Task 3, kneeling on left knee, Sensor 3, located on patella has the highest value. The one exception is with subject 3 where Task 5, Sensor 3 has the highest value. This could be due to the kneeling habits of that particular person. Subject 4 displayed no significant pressures for sensors 1 and 3, this could be attributed

to sensor location. Examining the normalized values further, sensor 1, located on the back side of the knee underneath the top strap, has an average maximum pressure of 18% of the maximum pressure for that subject during task 3 and an average maximum pressure of 24% of the maximum pressure during task 5.

In Figures 20 to 22 the raw values for the different sensors are compared for person to person and task to task. It can be seen in Figure 22 that sensor three has the highest recorded pressure values. Figure 21 has the second highest recorded values, but these values are for subject 2 only and are not observed with the other subjects.

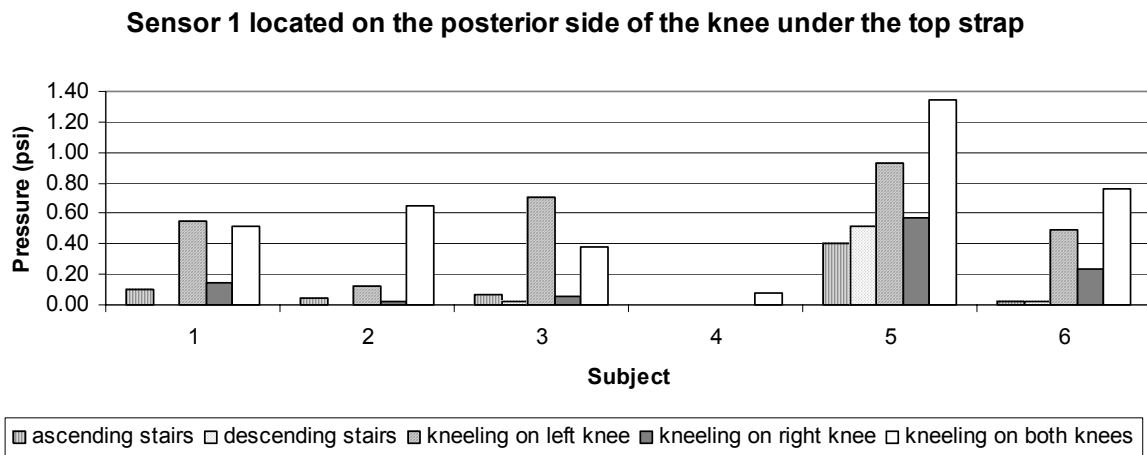

**Figure 20: Values for Sensor 1 by subject for different tasks**

For sensor 1 subject 5 had the highest recorded value when kneeling on both knees. The next highest value occurred when kneeling on left knee. For all of the subjects the highest recorded values for this sensor were recorded when kneeling on the left knee.

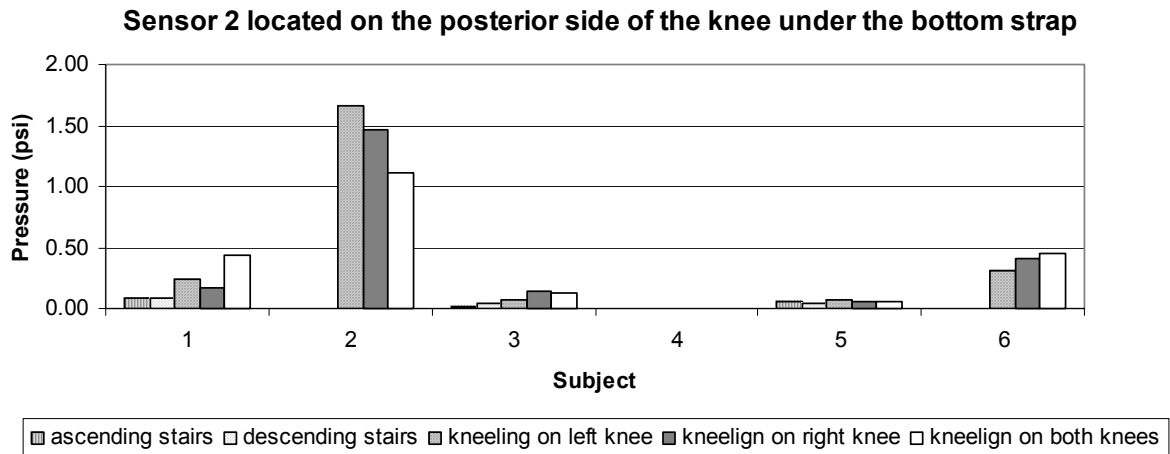

**Figure 21: Values for Sensor 2 by subject for different tasks**

With the exception of subject 2 none of the subjects have a pressure reading over 0.5 psi. For subject 2 the kneeling tasks revealed pressures over 1 psi.

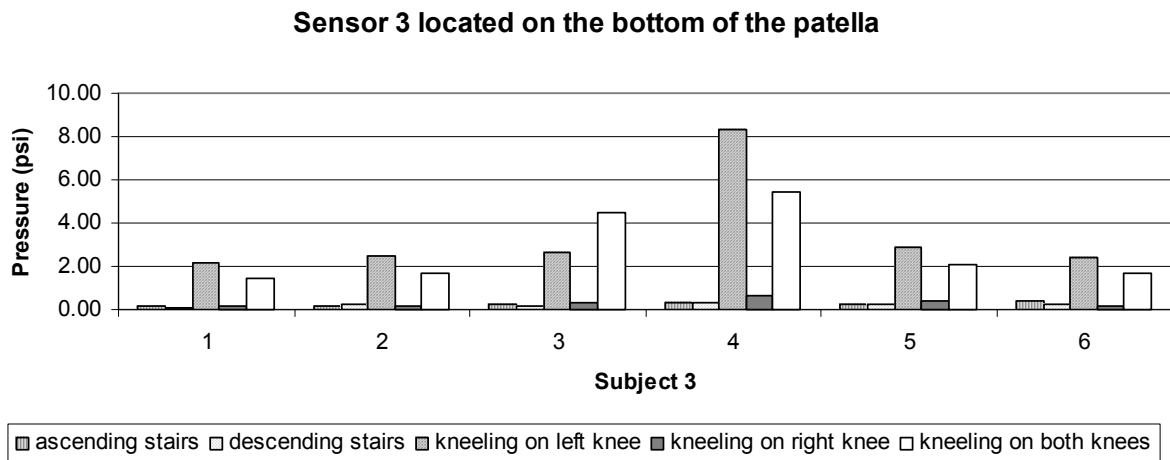

**Figure 22: Values for Sensor 3 by subject for different tasks**

With the exception of subject 3 the task of kneeling on the left knee produced the highest recorded values for each subject with kneeling on both knees the next highest. All of the subjects had a pressure reading of over 2 psi for the third task with subject 4 having the highest recorded pressure at over 8 psi.

Another interesting observation is the time when the maximum pressure occurred for Sensor 1 for a couple of the subjects. When comparing the knee angle, Figure 23, the pressure readings from Sensor 1, Subject 2, (Figure 24) it can be seen that the maximum pressure occurs when the person is getting into and out of the kneeling position. For the third sensor the highest recorded values were measured when the knee was at the maximum flexion angle, that is, when the knee was on the ground. Increases in pressures were also recorded by this sensor whenever the knee was bent, minor pressures were measured during stair ascent and descent and greater pressures were measured during kneeling on the right knee.

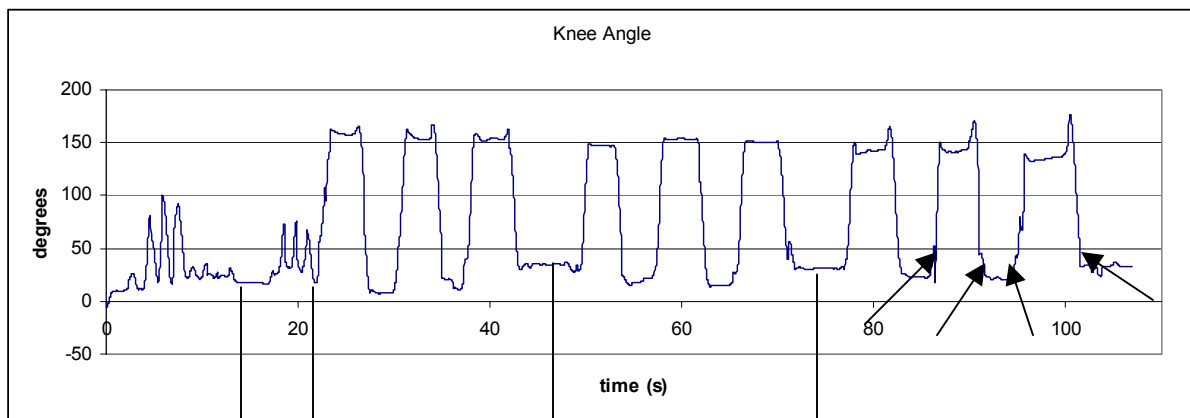

**Figure 23: Knee Angle**

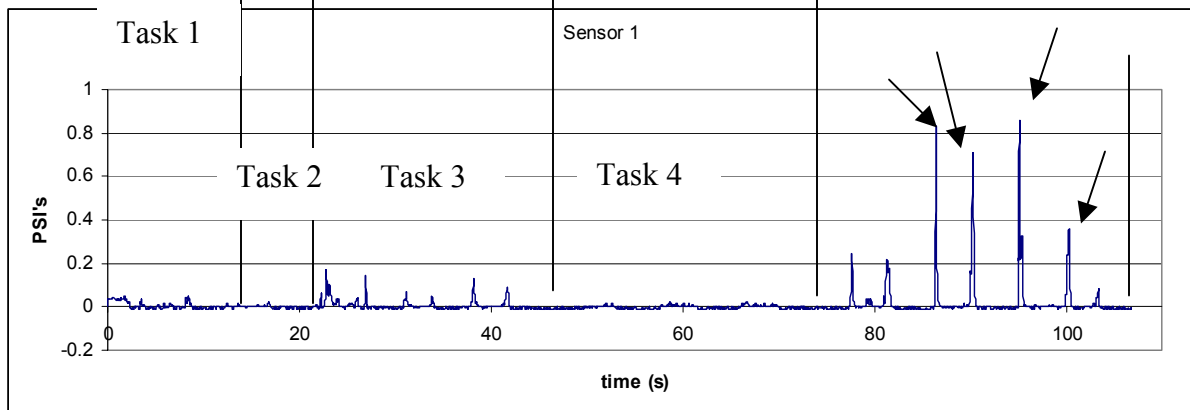

**Figure 24: Pressure Sensor 1, pressure reading peaks for going into and out of kneeling position.**

Since comfort is really a personal opinion each subject was asked to fill out a survey pertaining to the comfort of the knee pad. None of the subjects indicated that the

knee pads were uncomfortable or that they felt discomfort while wearing them. Two subjects did indicate that they felt moderate discomfort under the straps when kneeling but did not indicate any other discomfort, one of the subjects did had a pressure recorded of around 0.5 psi but was the fourth lowest pressure recorded by that sensor for that task among the subjects. Two subjects also indicated that the knee pads did not stay properly attached unless the straps were tightened significantly. Two of the subjects felt that the knee pad restricted their range of motion. Results from the survey appear in Figure 25.

1. Did the kneepads stay properly attached to your knees during movement?  
 “YES” 66.7%
2. Did the kneepad restrict your range of motion?  
 “YES” 33.3%
3. Did the kneepad restrict your circulation?  
 “YES” 0%
4. Did the kneepad fit properly?  
 “YES” 66.7%
5. Using the scale provided, please rate the kneepad for the following criteria. Circle ONE number for each. If you can not answer for a particular item, circle “N/A.”

	UNCOMFORTABLE	MODERATE	NEITHER	MODERATE	COMFORTABLE
	1	2	3	4	5
a. Comfort when kneeling			3.5		
b. Comfort when prone			3.7		
c. Comfort when walking			4		
d. Comfort when standing			4.3		
e. Comfort overall			4		

6. Did you experience any binding or discomfort from the kneepad?  
 “YES” 33.3%

**Figure 25: Results of the knee pad survey, n = 6**

## **Chapter 5: Discussion**

In this section the data acquisition system will be evaluated and the results of the studies will be discussed.

### **Section 5.1 Data collection system**

This project involved measuring three different variables: pressure, stride interval and knee angle. Three different sensors, foot switches, a knee goniometer and pressure sensors were used in the process of collecting these data. All of the sensors were powered by custom made drive circuits that incorporated considerable field wiring. The signals from the sensors were recorded by a data acquisition card in a laptop computer. Due to the fact that the sensors and the DAQ card were all made by different companies each sensor required its own separate circuit with different components such as different opamps, resistors, and voltage regulators. Also each sensor had to interface correctly with the DAQ card. To do this the output from the sensors had to be within a certain voltage (0 to 5V), and exhibit sufficient changes in signal so it clearly exceeded background noise  $< 0.1V$ .

#### **Section 5.1.1 Force Sensors**

The sensors used to measure pressure beneath the knee pad functioned properly and gave good results. The only difficulties that were encountered with the force sensors were during the initial lab testing. There was cross interference between different sensors, when one sensor had a load applied to it all of the other sensors also showed an applied load. This problem was traced to the opamp being used. The opamp was changed out with a different one and the problem went away.

### **Section 5.1.2: Knee Goniometer**

The knee goniometer was the best performing sensor, it had little to no drift in the output signal and was highly reproducible from trial to trial. After calibration of the goniometer knee angles were accurately measured. The only draw back to the goniometer was aligning it with the knee to make sure that the angle being measured was anatomically correct. To do this the lower part of the goniometer was taped onto the lower leg visually aligning it between the knee and ankle. The other part of the goniometer was visually aligned along a line between the knee and hip. The result of this method did lead to minor variations, approximately  $\pm 7^{\circ}$ , from person to person for the measurement of the absolute knee angle. The exact knee angle was not needed because in the gait analysis the maximum flexion was used. At the point of maximum flexion the output voltage was at a maximum, so this signal was never converted into degrees. During the pressure analysis, since it was task oriented and people went into and out of the kneeling position rapidly no correlation could be drawn between knee angle and pressure. The knee angle was used to help differentiate between different tasks. The convention used to measure the knee angle in both the gait analysis and force analysis was to establish  $0^{\circ}$  when the leg was straight. The measured angle was then positive with increasing flexion corresponding to the increased output voltage.

The only problems that arose with the knee goniometer were during the gait testing. While the people were walking around on the track it was felt by the tester that a slightly longer cable from the goniometer to the computer would have been useful. However since the cable had a unique connector and was supplied by the manufacturer this would have entailed splicing on an extension which could have led to additional

problems. Since the supplied wires were a high gauge (very thin), breakage of these wires when connecting them to additional wires was a concern. The other problem encountered was the signal from the gait test the last three subjects was not usable. The problem was traced to an insufficient power source, the battery powering the goniometer was dead. To help prevent this in the future battery checks could be performed before each test. Only one subject had a problem with the goniometer coming loose but this did not affect the results since it occurred near the beginning of the run and the data run was restarted.

### **Section 5.1.3 Foot Switches**

The footswitches were the key sensor for gait analysis because if working correctly give a very accurate representation of the stride interval time series and the analysis was performed on the stride interval time series. The footswitches were also the hardest sensor to get to perform acceptably. Initially these sensors were going to be sampled at a rate of 200 Hz in order to be able to record the dual stance time in gait. However initial laboratory tests of this sensor showed difficulty recording at this frequency. There was significant noise in the signal i.e., when the sensor was supposed to have an output of 5 volts, there would be spikes in the data ranging from 5 down to 2 volts for a duration of approximately 0.015 seconds (3 data points). The same thing was also happening when the output was supposed to be 0 volts where there would be spikes in the data ranging from 0 to 2 volts. These spikes in the data occurred roughly every 1.1 seconds. Several different filters, using both hardware and software, were used to try and eliminate these spikes but that was unsuccessful. The source of the spikes in the data was never determined. The solution was to sample the sensors at 30 Hz, which was the fastest sampling rate without getting the spikes in the data. Due to a lower sampling rate the dual stance time could no longer be measured without significant error in the time value.

Initial field testing of the foot switches showed the sensors were registering false heel strikes, disrupting the ability to accurately measure the stride interval. Several different field tests were performed to eliminate this problem but were unsuccessful. This led to the rebuilding of the drive circuit still using the same concept but a different circuit layout. The rebuilt circuit did not fix the problem either; the signal still had considerable noise. At this point the decision was made to remove the noise manually after the data were collected as demonstrated in the methods section (Figure 10).

#### **Section 5.1.4: Comparison of foot switches and goniometer**

Based on the signals obtained and the overall performance of the goniometer and the foot switches, more reliable data was obtained from the goniometer. When analyzing the stride interval data the initial signal recorded by the DAQ card from the goniometer was a lot cleaner than the data from the foot switches. In the goniometer data local maximums in the signal were detected and the stride interval was taken from that time series. With the foot switches in order to determine the stride interval an edge detection was performed on the time series, however, as mentioned earlier there was a problem with the signal from the foot switches where the signal recorded had false heel strikes in the data, leading to an incorrect data series. This was not the case with the goniometer, there were very few, if any, false positives.

Another advantage of the goniometer over the foot switches was the goniometer was capable of recording at much higher frequencies than the foot switches without the problem of noise in the signal. In laboratory tests the goniometer was sampled at a rate of 1000 Hz. (one sample every 0.001 seconds) and still had a clean signal, as opposed to the foot switches where the fastest usable recording rate was 30 Hz (one sample every 0.033 seconds).

## **Section 5.2 Data Analysis**

Since the system used to acquire the data was a home built system there was not any software available to perform all of the different analyses. To perform the gait analysis of three different programs were used. With the pressure analysis only one program was used. Using multiple programs to analyze the data took longer to perform the analysis than it would have taken if only one program was used. In addition files had to be saved in a file format that could be recognized by the other programs.

### **Section 5.2.1 Gait Analysis**

Due to the limitations of the foot switches where a sampling rate of 30 Hz. was the maximum sampling rate possible there is an increased uncertainty in the time signal used to determine the stride interval. Since the average recorded stride interval recorded was 1.1 seconds there is approximately a maximum error of 6% in the determination of the stride interval.

Due to the errors in recording, false positives, the stride interval time signal had to be edited, by visually inspecting each point as described in Section 3.6.1. In all of the different subjects less than 2% of the data had to be deleted, meaning less than 2% of the stride interval values were greater than 1.3 seconds or less than 0.9 seconds with no adjacent value next to it to add up to the average stride interval. In the other situation where stride intervals had to be added together the percent varied between subjects. In one subject less than 2% of the data had to be edited where as with one subject about 25 to 30% had to be edited. On average about 15% of the data had to be edited in this manner, time values had to be added together.

Tests on the subjects showed there were no significant changes in the correlation coefficient ( $\alpha$ ) between wearing knee pads and not wearing knee pads. Individual

variations in  $\alpha$  from one subject to another subject did exist. This means that everyone does not have the same gait pattern or that there were enough inaccuracies in the measurement to cause the  $\alpha$  values to vary. As stated (Hausdorff 1995) normal human gait has an  $\alpha$  value between 0.5 and 1 with 0.75 being the theoretical normal value. In the case of this thesis the  $\alpha$  values ranged from 0.39 to 0.72 with a mean value of 0.57 and a standard deviation of 0.10. Multiple statistical tests were performed on the gait analysis data. These tests included a Wilcoxon Signed-ranked test, two-tailed paired t-test. A correlation coefficient was also calculated to test the strength of the linear relationship between the two sets of data. In both of these tests and for the calculation for the correlation coefficient, data from trials with knee pads to trials without knee pads were compared as well as data from the left foot compared to the right foot. The tests showed constantly that no significant differences were found between the trials with knee pads and the trials without knee pads as well as left foot compared to right foot. Furthermore, for three of the subjects the goniometer was working correctly and the analysis of that time signal verified the result found from the left foot data of no significant differences. It should be noted that all of the subjects in this study walked counterclockwise around the track; had they walked clockwise around the track the results may be different. However, to accurately test this hypothesis a study with more people should be conducted with better working foot switches and the subject should walk in both directions around the track.

To verify these findings, the alpha values obtained were not random, two sets of data from subject 2 (left foot with knee pads and left knee with knee pads) were randomly shuffled and analyzed using the same techniques as previously described. The result of

the analysis proved that the initial findings were valid since the randomized data approaches and alpha value of 0.5, white noise.

To add further creditability to this study the findings of this study coincide with the finds of studies performed by West *et al.* In his findings West states the stride-interval time series is fractal and there are long-time correlations in walking.

In this study the person did three laps around a track to obtain the stride interval time series, the approximate time it took for the person to walk this distance was around 15 minutes, creating a stride interval time series of approximately 800 foot falls. In the studies performed by West he had his subjects walk for 15 minutes to create a time series of approximately 800 foot falls. In the studies performed by Hausdorff (1995), he had his subjects walk for around 9 minutes creating a time series of almost 500 foot falls. In the same study he had a subject walk for an hour and then analyzed the time signal. His findings from this study did not vary from his previously studies, it only helped to validate the length of his previous studies. In a study performed by Keenan (2002) to determine how many stride intervals were needed to calculate a fractal pattern in gait he determined that only 25 successive foot falls were necessary to accurately determine the fractal pattern.

### **Section 5.2.2 Pressure Analysis**

All of the subjects displayed similar results; an increase in pressure on sensor one during knee flexion and an increase on sensor three during kneeling. The highest pressure was recorded by the pressure sensor located on the patella during kneeling on the left knee. Since the weight of the subject does affect this outcome, the data were normalized to the value recorded by the sensor for this task. There was one subject where the highest

value recorded was found when they were kneeling on both of their knees. The cause of this is more than likely due to that person's individual kneeling style where they may not have put as large a percentage of their weight on their left knee when kneeling on it as the other subjects did. With the exception of this subject the pressure recorded by sensor 3 for kneeling on both knees is around 70% of the value recorded for sensor 3 kneeling on left knee. These measurements suggest a more distributed loading of the person's body weight between their two knees while kneeling on both knees as opposed to kneeling on just one knee. For the subject where this was not observed in, it would suggest that he maintained a fair amount of weight on his right foot while kneeling on his left knee.

Another factor affecting the results of the pressure sensors was the placement of the sensor on the person. Each sensor was located in approximately the same location on each person, however they were not in exactly the same location on every person. Sensor 1 was perhaps the hardest to position. The ideal position of the sensor was under the top strap positioned over the tendon that attaches the hamstring to the knee. If not aligned correctly the sensor may not record the intended force. The physiological build of each person also affects the results. For this experiment a size medium knee pad was used. One subject could have benefited better from a size large and three subjects from a size small.

After reviewing the questionnaire and the results from the pressure measurements it is not possible to put a numerical value on comfort at this point. The responses of two surveys do indicate that there was moderate discomfort during the task of kneeling. Only one of the subjects indicated the pressure was felt under the straps, in the location of pressure sensors 1 and 2. For this subject (1) the pressure was 0.55 psi under pressure sensor 1 during task 3. No other task received any type of a discomfort mark by any of

the subjects. Kneeling was the only task that received any marks for being uncomfortable and was also the task that had the highest pressure recorded. However it is difficult to specify a pressure threshold where the knee pad becomes uncomfortable.

### **Section 5.3: Sample Size**

After performing a power analysis on the gait data using  $\alpha = 0.75$  as the theoretical average and  $\alpha = 0.6$  as the actual average with standard of deviation of 0.04 it was calculated for a level of significance of 0.05 the sample size should be at least 5 subjects. Since this study used 6 subjects the results appear to be valid.

## **Chapter 6: Conclusions:**

This thesis had three goals. The first was to develop a data acquisition system that was capable of measuring knee angles, stride intervals and pressure all at the same time at a desired sampling rate. The second goal was to determine if knee pads had any effect on long term gait correlations by performing a fractal analysis on the stride interval time series. The third goal was to evaluate the forces the knee pad exerts on the knee during different tasks such as climbing stairs and kneeling.

The first goal was accomplished by building a data acquisition system from the ground up. The DAQ card that was purchased was more than sufficient for the tasks at hand, and the knee and pressure sensors worked extremely well. Although there were problems with the foot switches their overall performance was acceptable and did lead to valuable data. A time signal was able to be captured from multiple sensors that with filtering was able to be analyzed. After analyzing the time signals and performing multiple statistical tests on the data sets, it can be concluded that the knee pads do not have any significant effects on long term gait patterns of the stride interval. However with the extent of the filtering that had to be performed and the low sampling frequency there is a possibility that the alpha values could be affected. Additional studies with the goniometer sampling at higher frequencies and one on each knee could help to eliminate these concerns. Furthermore, with the variations in the alpha values between the left foot and the knee goniometer there is a possibility that two different things are being measured. To investigate this possibility further research could be done in comparisons for the time signals for the foot and knee.

None of the users reported any significant discomfort from the kneepads in the five tasks they performed. Pressure recorded by the sensors did indicate the greatest

pressures were measured by sensor 3, on the front of the knee during the task of kneeling, either on the left knee or on both knees. It was also during kneeling that the highest values were recorded for pressure sensor 1, located underneath the top strap. An additional study could be performed to see if using pressure sensors on the other knee as well could give indication to that person's kneeling habits which could possibly give information about comfort.

Overall this thesis gives no indication that knee pads affect long term gait patterns, and with the tasks being performed comfort cannot be directly measured. Comfort may be related to the amount and location of the applied pressure but no quantitative values were able to be determined.

## **Chapter 7: Recommendations**

There are several recommendations to be made for future work in this area. These recommendations include adding to or changing the current hardware, software and equipment.

With respect to the hardware, positioning of the sensor proved to be a challenge and may have affected the outcome of the results. If a pressure sensor with a larger sensing area could be found that would be beneficial. Tekscan<sup>®</sup> makes a sensor that is square in shape and creates a pressure map of the sensing area; this would be beneficial under the straps. The foot switch system needs to be refined by either building a different drive circuit or using a filter so there is less noise in the time signal and possibly designing it to accommodate higher sampling rates. The data acquisition system should also be made a lot smaller so it can be worn by the subject eliminating the need for a person to carry a computer, a portable data recorder would work nicely for this.

With respect to the software, for the gait analysis it would be beneficial if the entire analysis could be performed in one program instead of having to use multiple programs. This would save on both time and storage space for the analysis.

Although the power analysis determined that enough subjects were used it would still be beneficial to perform the study again with a larger and more diverse population. For example, women should be included in the next study. It would also be of some interest to see the performance of other kneepads with different designs, such as slip on and off, imbedded knee pads in pants, soft shell knee pads and knee pads of different sizes.

## References:

U. H. Buzzi, N. Stergiou, E. Markopoulou, 2002, "A Dynamical Analysis of Parkinsonian Gait", *Proceeding from World Congress of Biomechanics*.

Joseph Carvalho M.D., 1992, *Military Medicine*, Letters to the Editor.

A. L. Goldberg, L. A. N. Amaral, J. M. Hausdorff, P. Ch. Ivanov, C.-K. Peng, H. E. Stanley, 2002, "Fractal dynamics in physiology: Alterations with disease and aging", *PNAS* vol. 99, 2466-2472.

A. L. Goldberger, L. A. N. Amaral, L. Glass, J. M. Hausdorff, P. Ch. Ivanov, R. G. Mark, J. E. Mietus, G. B. Moody, C-K Peng, H. E. Stanley, 2000, PhysioBank, PhysioToolkit, and PhysioNet: Components of a New Research Resource for Complex Physiologic Signals. *Circulation* **101**(23):e215-e220 [Circulation Electronic Pages; <http://circ.ahajournals.org/cgi/content/full/101/23/e215>].

L. Griffin, D. J. West, B. J. West, "Random Stride Intervals with Memory", 2000, *Journal of Biological Physics* vol. **26**, 185-202.

J. M. Hausdorff, C.-K. Peng, Z. Ladin, J. Y. Wei, A. L. Goldberg, 1995, "Is walking a random walk? Evidence for long-range correlations in stride interval of human gait", *J. Appl. Physiology* vol. 78, 349-358.

J.M. Hausdorff, Z. Ladin, J.Y. Wei, 1995, "Footswitch System for Measurement of the Temporal Parameter of Gait", *J. Biomechanics* Vol. 28, 347-351.

J. M. Hausdorff, L. Zeman, C.-K. Peng, A. L. Goldberg, 1999, "Maturation of gait dynamics: stride-to-stride variability and its temporal organization in children", *J. Appl. Physiology* vol. 86, 1040-1047.

J. M. Hausdorff, D.A. Rios, H.K. Edelberg, 2001, "Gait Variability and Fall Risk in Community-Living Older Adults: A 1-Year Prospective Study", *Arch Phys Med Rehabil* vol. 82, 1050-1056.

S. M. Keenan, N. Stergiou, 2002, "The Reliability of the Lyapunov Exponent During Treadmill Walking", *Proceeding from World Congress of Biomechanics*.

S. M. Keenan, N. Stergiou, 2002, "The Effect of Speed on the Deterministic Origin of the Variability Present During Human of Locomotion", *Proceeding from World Congress of Biomechanics*.

John F Kragh. M.D., *Military Medicine*, Letters to the Editor, 1992.

M. J. Kurz, N. Stergiou, 2002, "Individuals with ACL Reconstruction Display Altered Long-Range Fractal Gait Patterns", *Proceeding from World Congress of Biomechanics*.

M. J. Kurz, N. Stergiou, 2002, M. M. Scott, "Individuals with ACL Reconstruction Display Altered Coordination Strategies While Walking and Running", *Proceeding from World Congress of Biomechanics*.

M. J. Kurz, N. Stergiou, 2002, K. McCormick, "Markov Model Suggests Neuromuscular Aging Affects Short-Range Correlations in the Gait Cycle", *Proceeding from World Congress of Biomechanics*.

M. J. Kurz, N. Stergiou, 2002, C. M. Millhollin, "Variability of the Lower Extremity Segmental Couplings Indicates that Elderly Gait is Less Stable During Stance", *Proceeding from World Congress of Biomechanics*.

Jacquelin Perry, 1992, *Gait analysis : normal and pathological function*, SLACK, NJ.

C.-K. Peng, J. E. Mietus, Y. Liu, C. Lee, J. M. Hausdorff, H. E. Stanley, A. L. Goldberg, L. A. Lipstiz, 2002, *Qualifying Fractal Dynamics of Human Respiration: Age and Gender Effects*, *Annals of Biomedical Engineering*, Vol. 30, 683-692.

C.-K. Peng, S. Havlin, H. E. Stanley, A. L. Goldberg, 1995, "Quantification of scaling exponents and crossover phenomena in nonstationary heartbeat time series", *Chaos* vol. 5, 82-87.

S .B. Taylor, R. K. Begg, R. J. Best, 2001, *Inter and intra-limb processes of gait control*, Proceedings of the IEEE Engineering in Medicine and Biology Society Conference.

B. J. West, L. Griffin, 1998, "Allometric Control of Human Gait", *Fractals* vol. 6, 101-108.

B. J. West, L. Griffin, 1999, "Allometric Control, Inverse Power Laws and Human Gait", *Chaos, Solutions & Fractals* vol. 10, 1519-1527.

David A Winter, 1991, *Biomechanics and motor control of human gait : normal, elderly and pathological*, University of Waterloo Press, Ontario.

[http://www.msha.gov/Illness\\_Prevention/ideas/kneepad.htm](http://www.msha.gov/Illness_Prevention/ideas/kneepad.htm), 3-9-04.

<http://www.sspc.org/regnews/regnewsotter/KneePads.html>, 3-9-04.

<http://snowboardsecrets.com/tips.htm>, 3-9-04.

## APPENDIX A: Sensor Calibration Equations

$V_i$  = Input Voltage (volts)

$P_i$  = psi

Angle = degrees

Pressure sensor 1:

$$P_1 = V_1 * 0.63 / 0.442$$

Pressure sensor 2:

$$P_2 = V_2 * 0.58 / 0.442$$

Pressure Sensor3:

$$P_3 = V_3 * 0.83 / 0.442$$

Goniometer:

$$\text{Angle} = V_4 * 55.58 + 11.1$$

## APPENDIX B: MatLab Code

### Gait Analysis: Foot switches

.m file written to create stride interval file from the time signal generated from the data acquisition card for the foot switches.

```
t = subject2r1(:,1);
c3 = subject2r1(:,4);

for a=1:29840
    if c3(a)<=0.7;
        c3(a)=0;
    end
end

for b=1:29840
    if c3(b)>=0.7;
        c3(b)=5;
    end
end

for c=2:29839
    c3(c)=(c3(c-1)+c3(c)+c3(c+1))/3;
end

for d=3:29839
    c3(d)=(c3(d-1)+c3(d)+c3(d+1))/3;
end

for e=1:29840
    if c3(e)<=0.01;
        c3(e)=0;
    end
end

for f=1:29840
    if c3(f)>=0.01;
        c3(f)=5;
    end
end

edge=diff(c3);
position=find(edge==-5);
time=t(position);
dt=diff(time);

plot(dt)
dt
```

## Gait Analysis: Knee Goniometer

.m file written to create stride interval file from the time signal generated from the data acquisition card for the goniometer.

```
t = subject4r1 (:,1);
c3 = subject4r1 (:,2);

for c=2:28399
    c3(c)=(c3(c-1)+c3(c)+c3(c+1))/3;
end

for d=3:28399
    c3(d)=(c3(d-1)+c3(d)+c3(d+1))/3;
end

for m=1:28400
    if c3(m)<0.48;
        c3(m)=0;
    end;
end;

%for n=4300:28320
% if c3(n)<0.2;
%     c3(n)=0;
% end;
% end;

B = imregionalmax(c3);
%edge=diff(B);
position=find(B==1);
time=t(position);
dt=diff(time);

plot(dt)
plot(t,c3,t,B)
plot (t,c3)
dt
```

## APPENDIX C: Gait Analysis for Subjects

Subject 1:

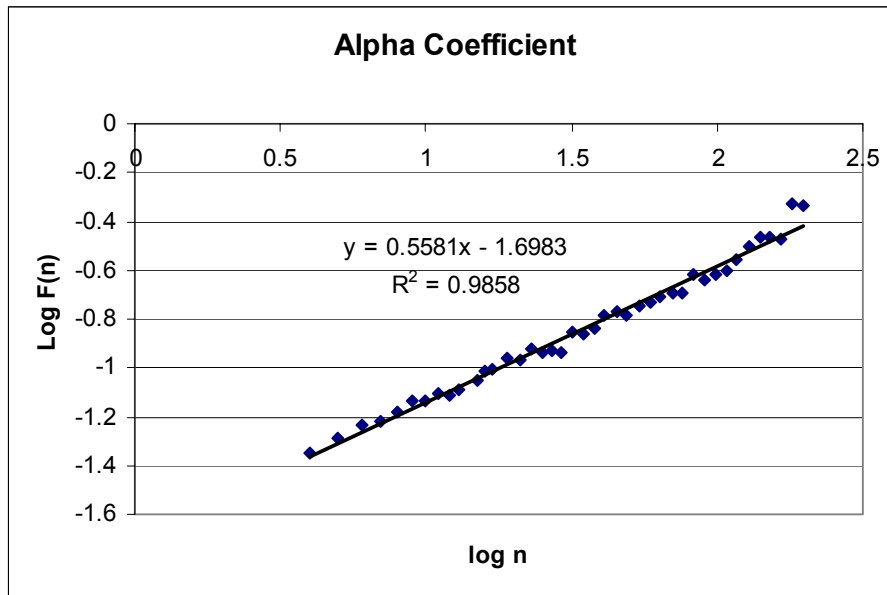

Figure 26: left foot with knee pads

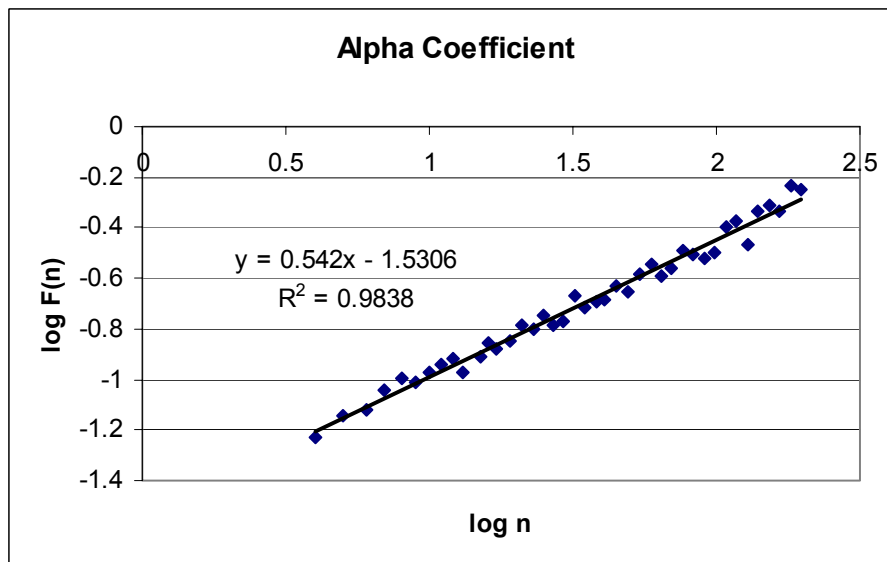

Figure 27: left foot without knee pads

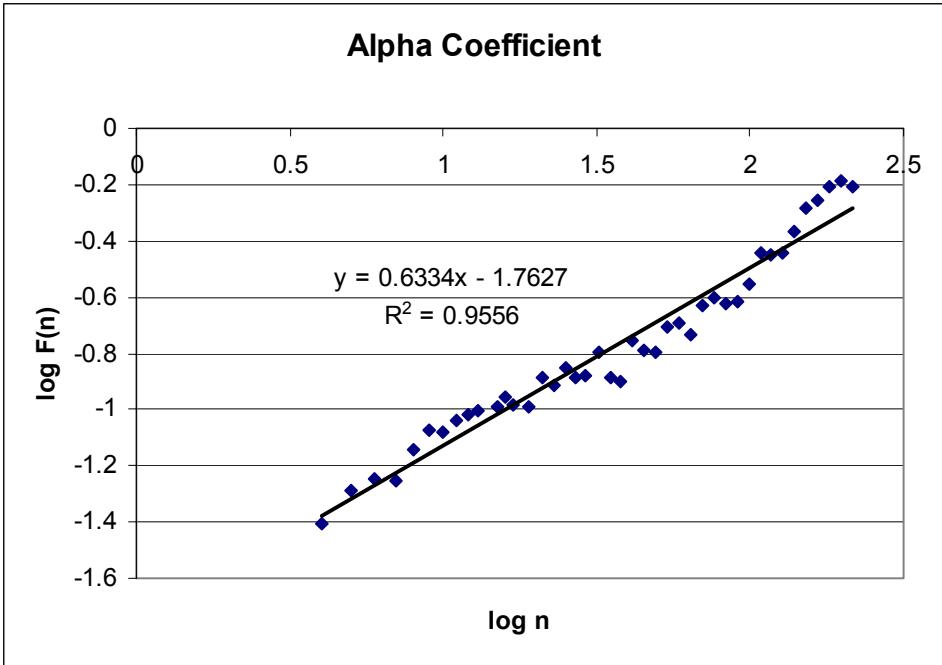

Figure 28: right foot with knee pads

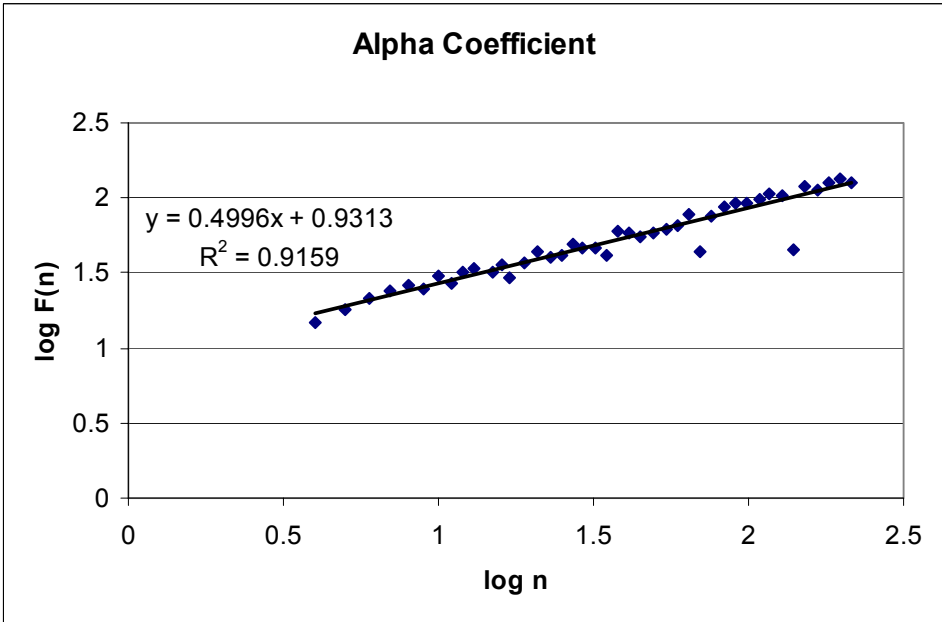

Figure 29: right foot without knee pads

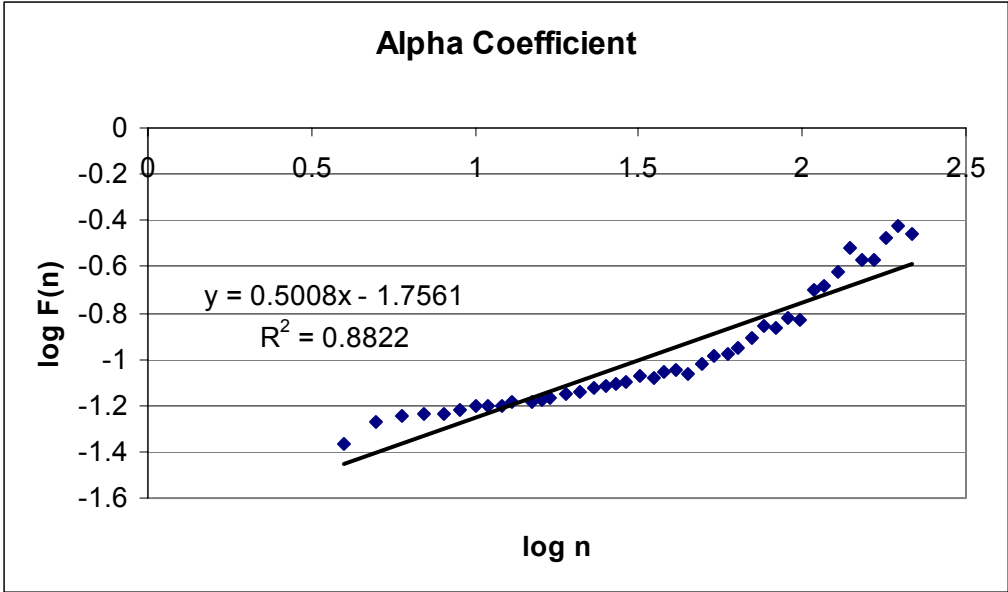

Figure 30: left knee with knee pads

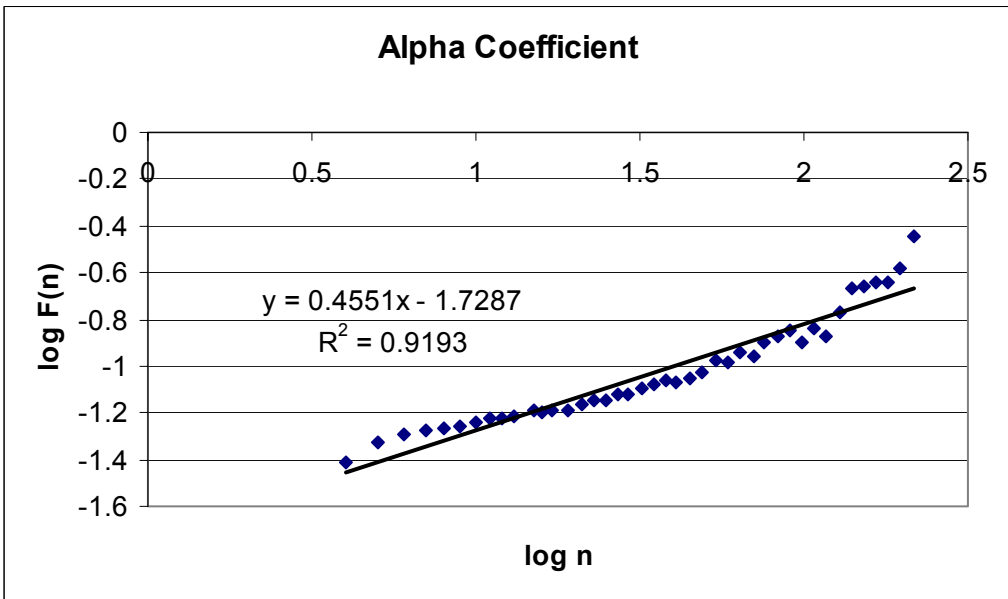

Figure 31: left knee without knee pads

Subject 2:

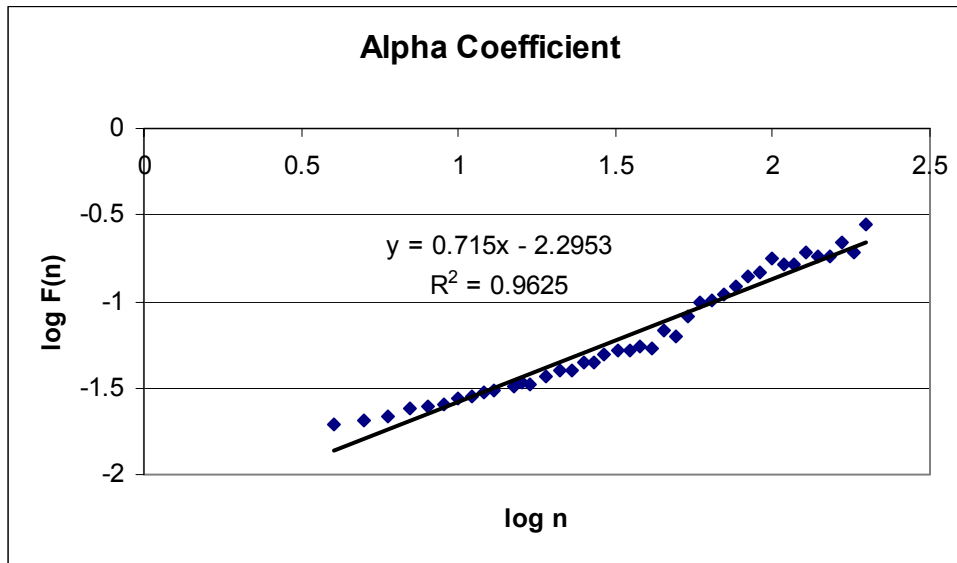

Figure 32: left knee with knee pads

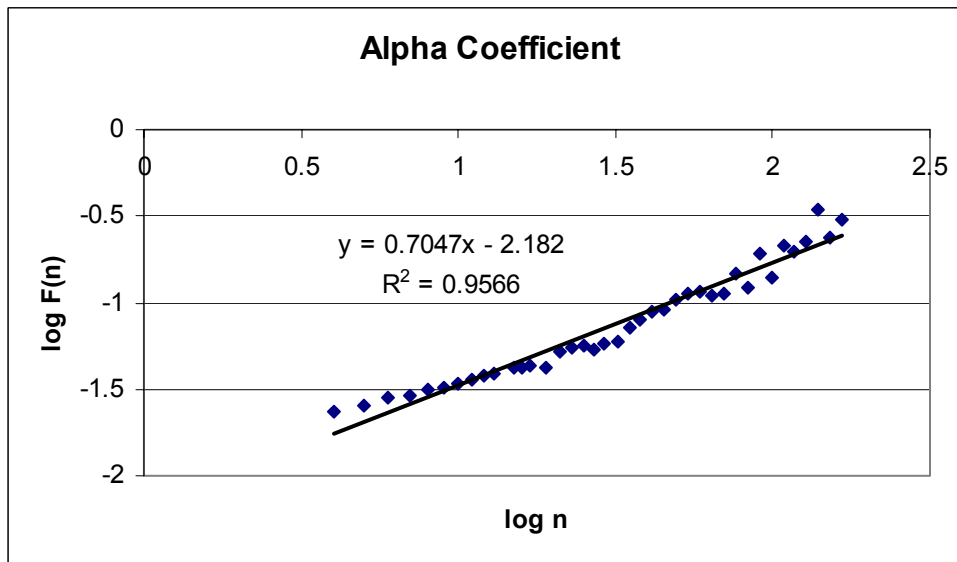

Figure 33: left knee without knee pads

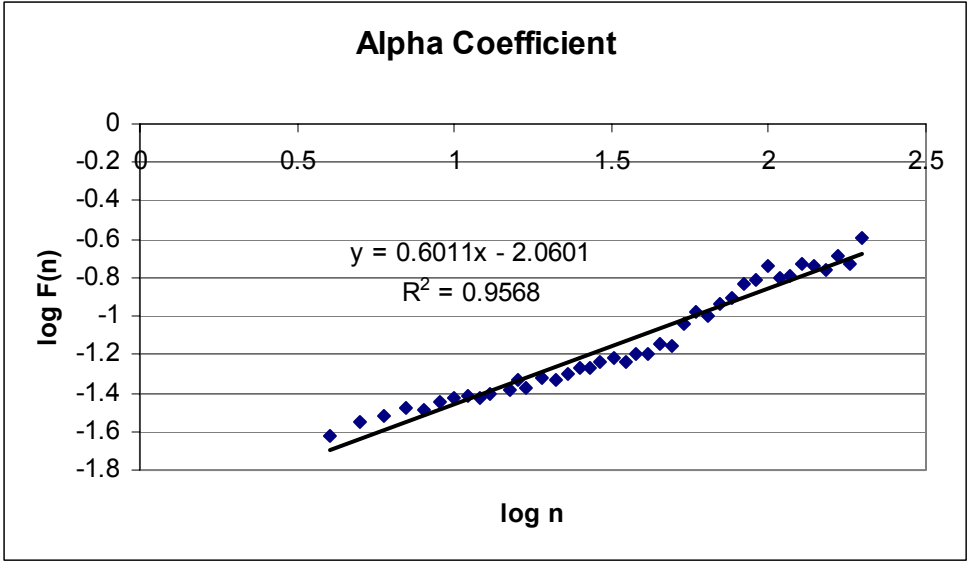

Figure 34: left foot with knee pads

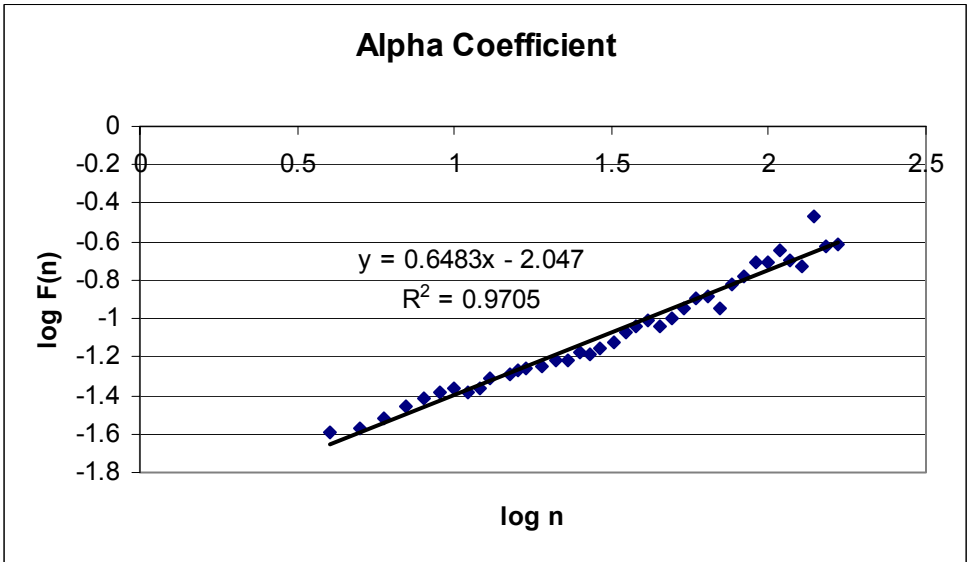

Figure 35: left foot without knee pads

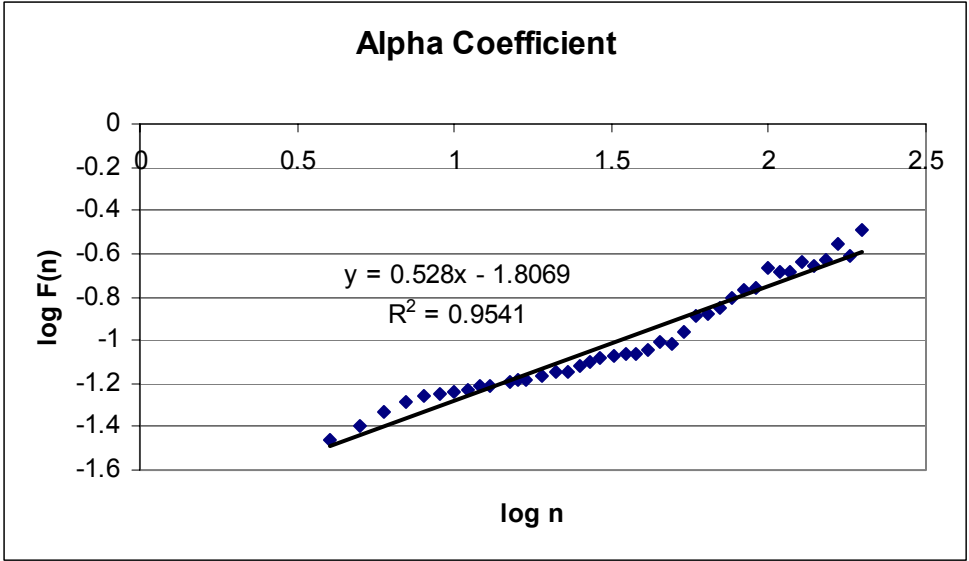

Figure 36: left knee with knee pads

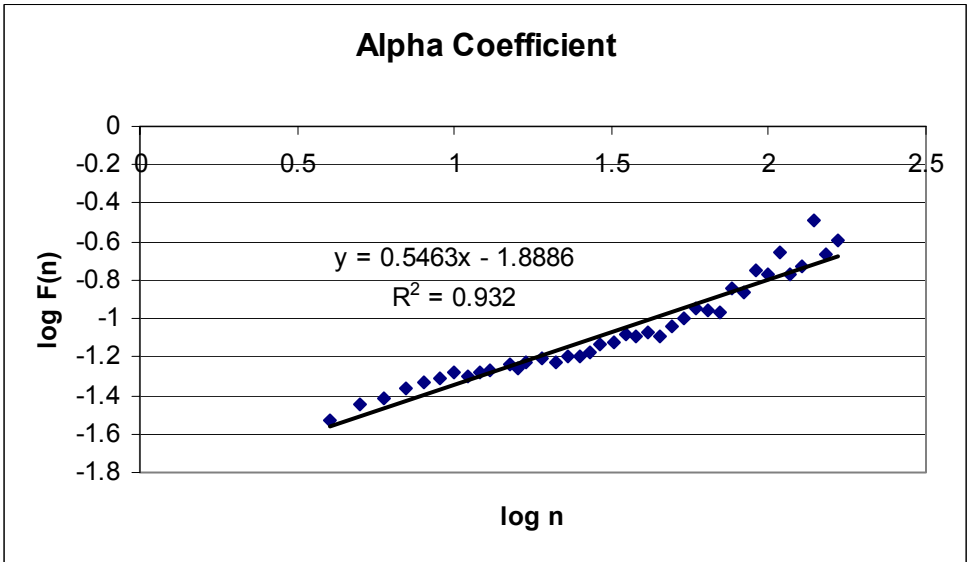

Figure 37: left knee without knee pads

Subject 3:

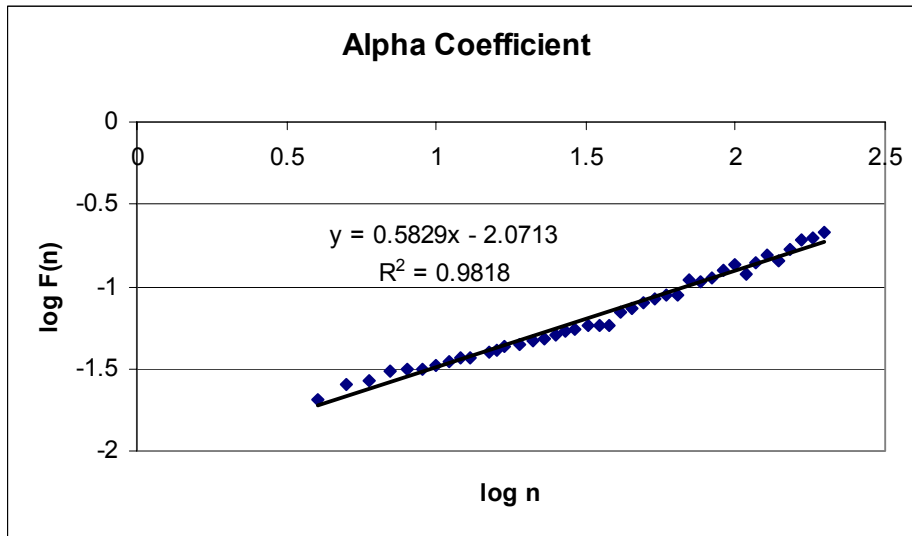

Figure 38: left foot with knee pads

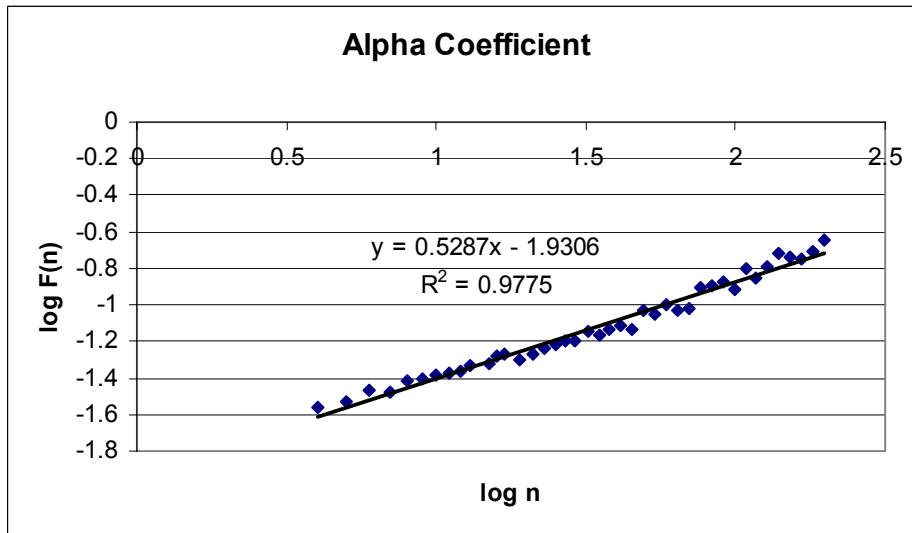

Figure 39: left foot without knee pads

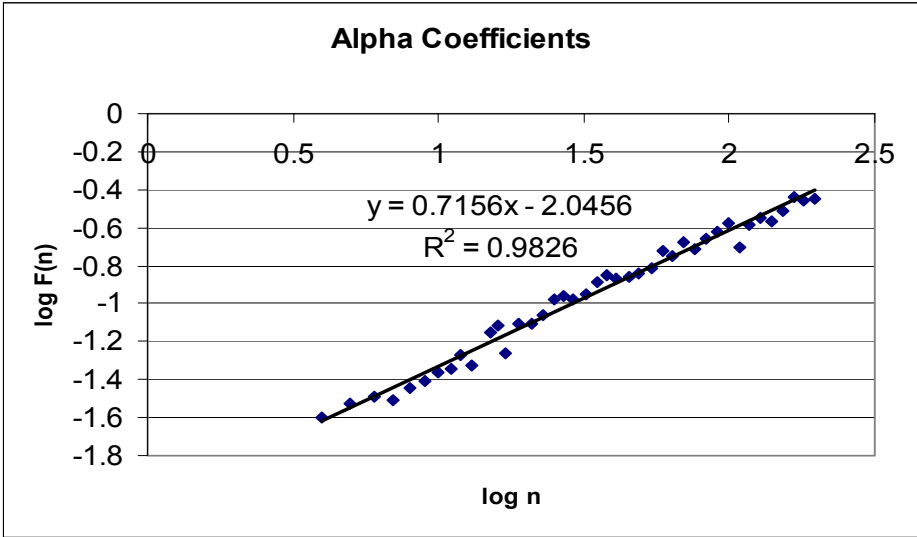

Figure 40: right foot with knee pads

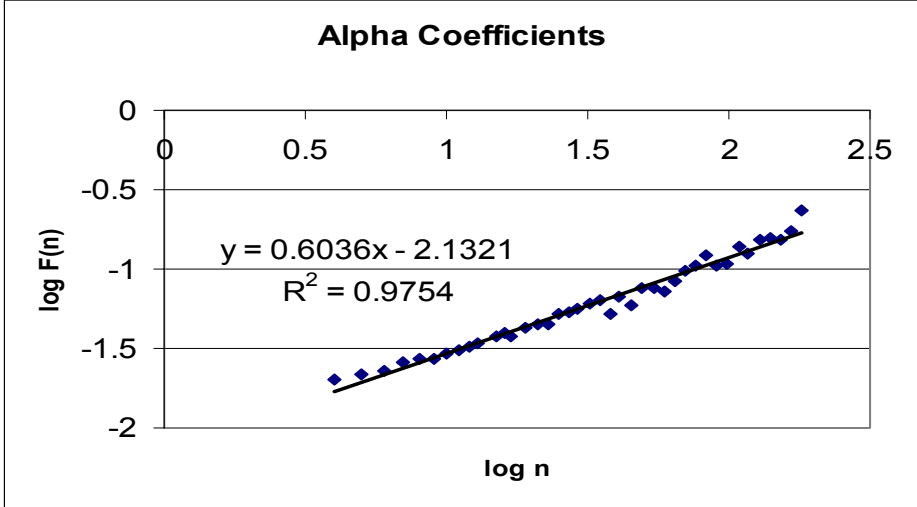

Figure 41: right foot without knee pads

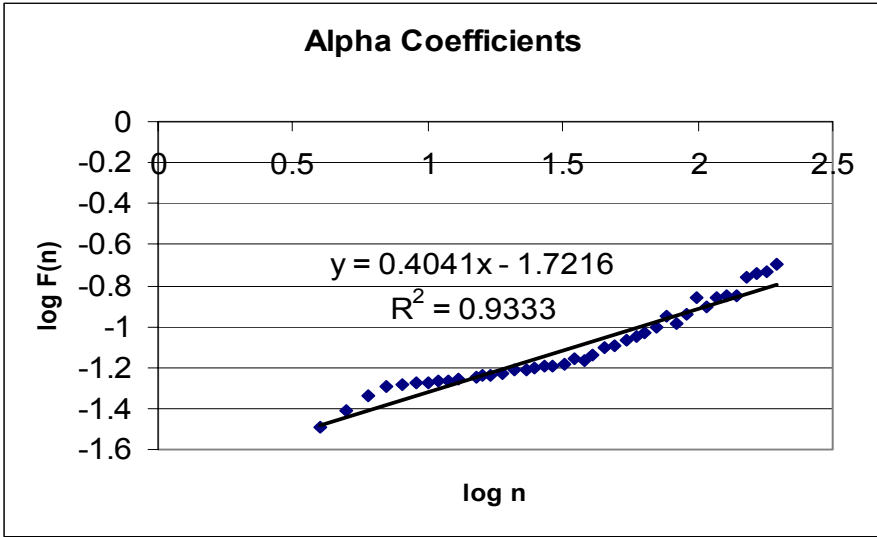

Figure 42: left knee with knee pads

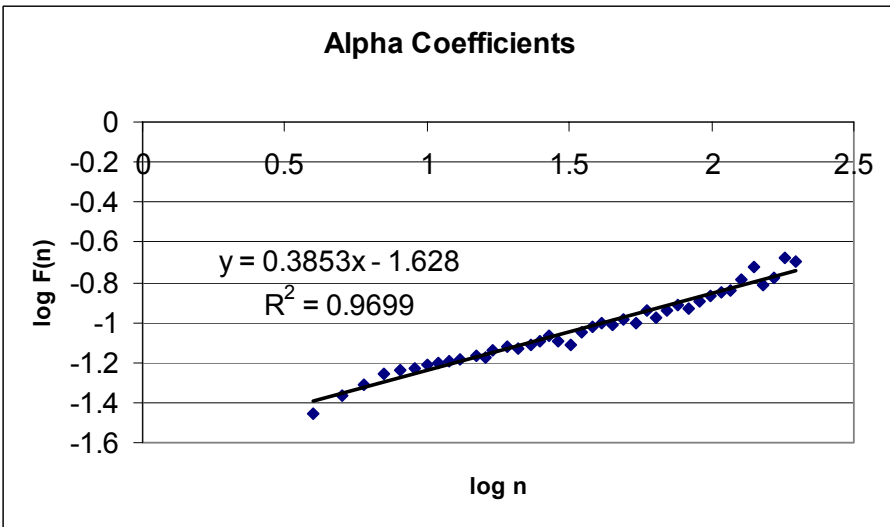

Figure 43: left knee without knee pads

Subject 4:

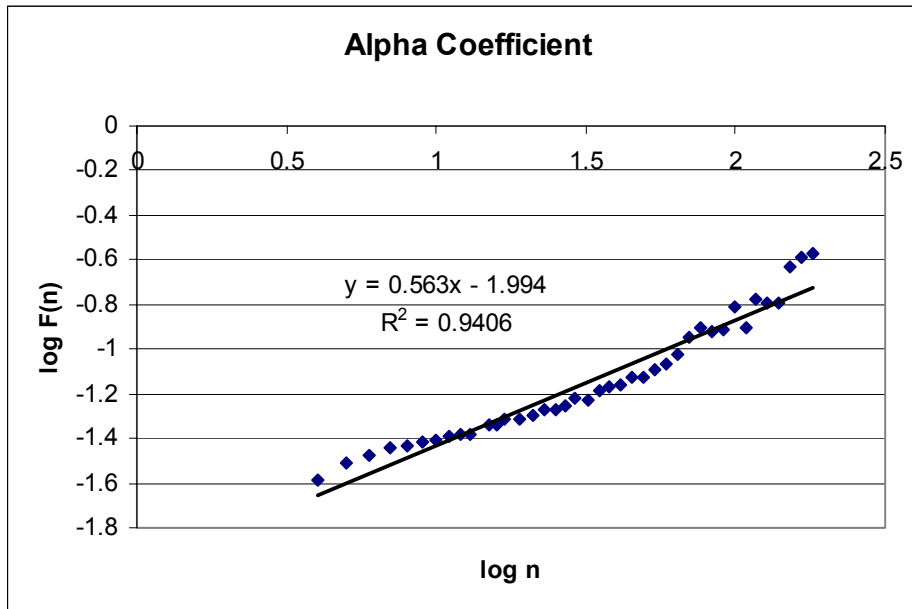

Figure 44: left foot with knee pads

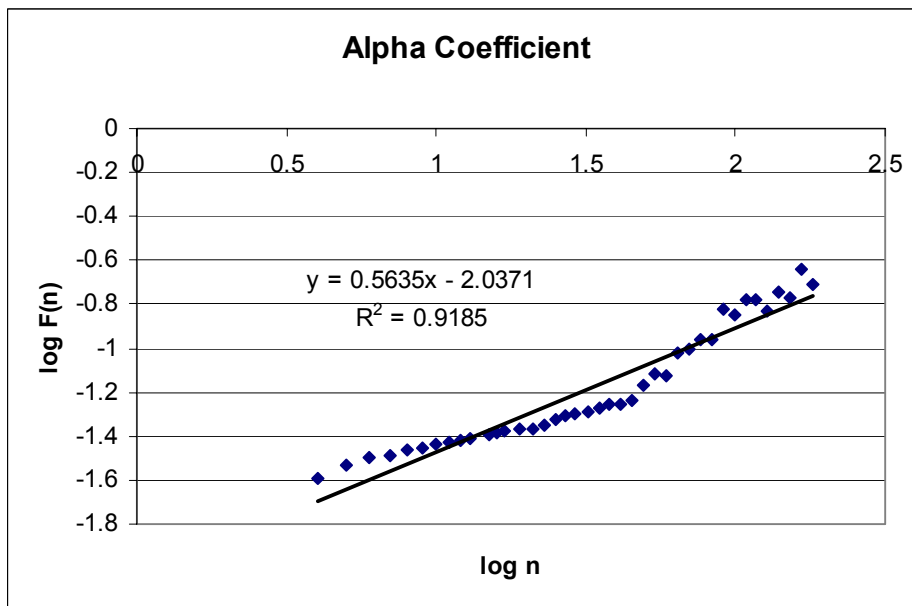

Figure 45: left foot without knee pads

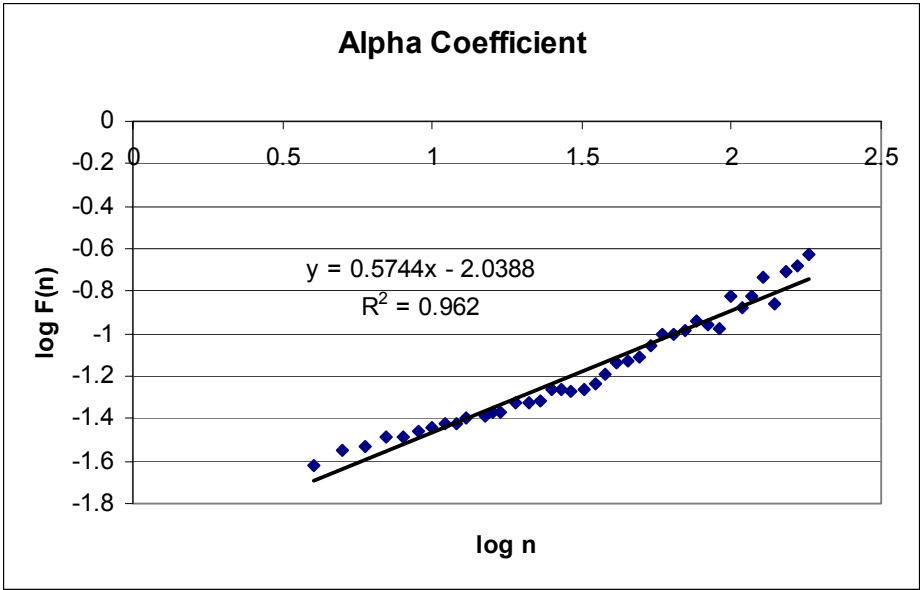

Figure 46: right foot with knee pads

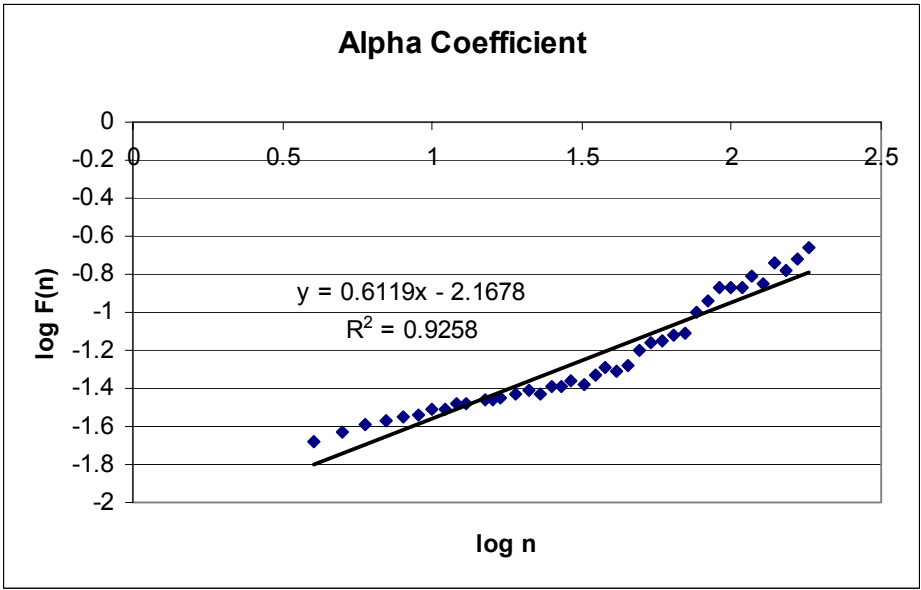

Figure 47: right foot without knee pads

Subject 5:

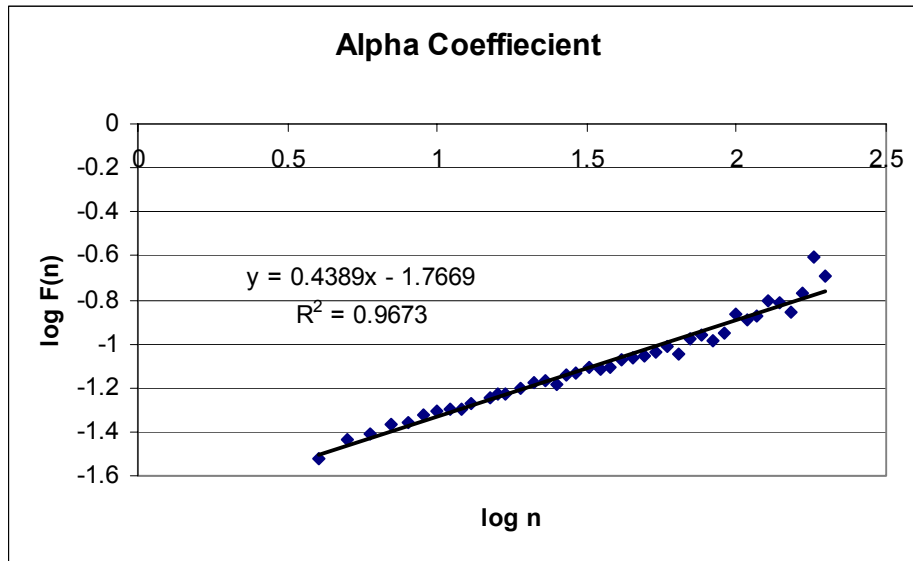

Figure 48: left foot with knee pads

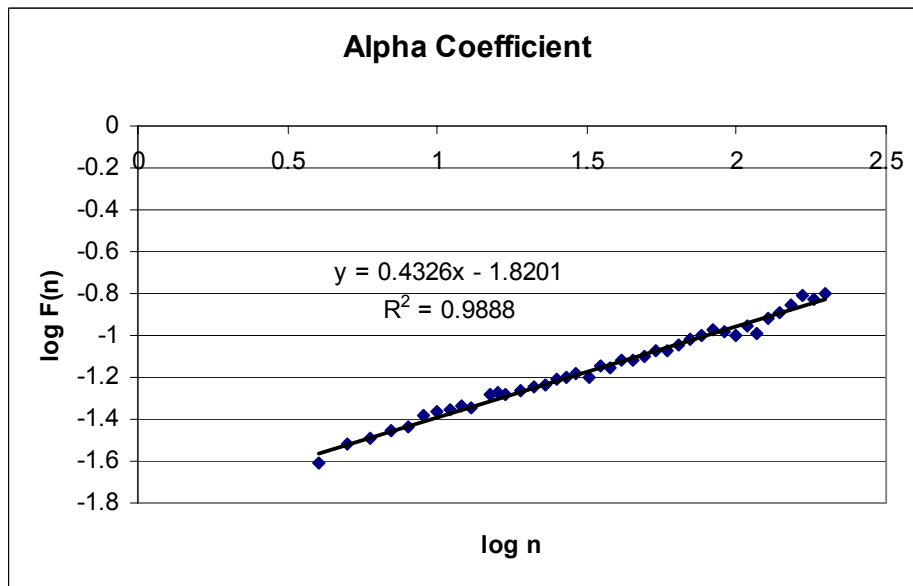

Figure 49: left foot without knee pads

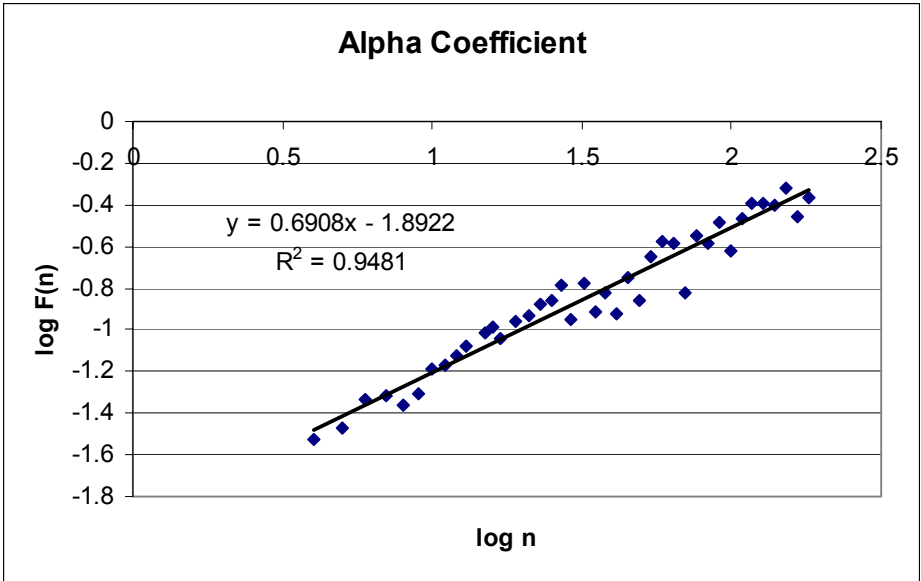

Figure 50: right foot with knee pads

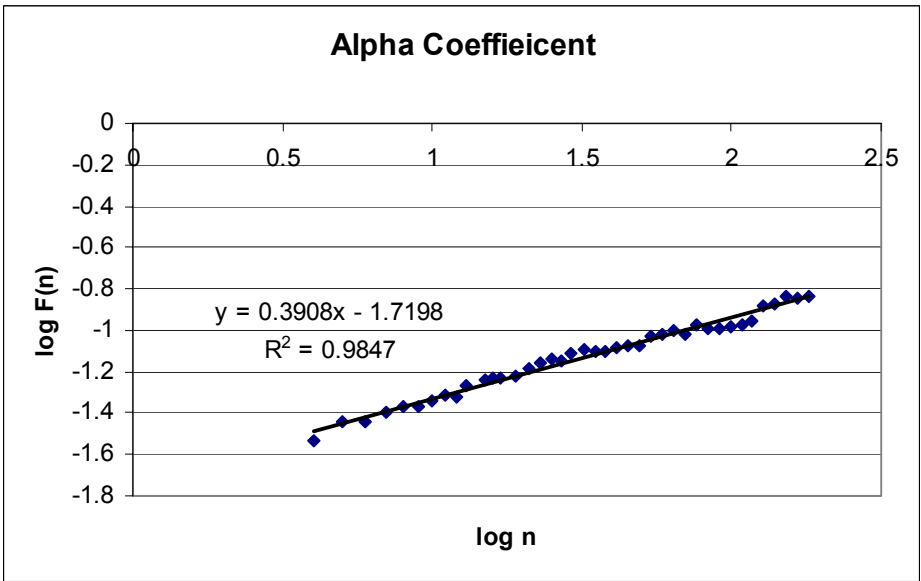

Figure 51: right foot without knee pads

Subject 6:

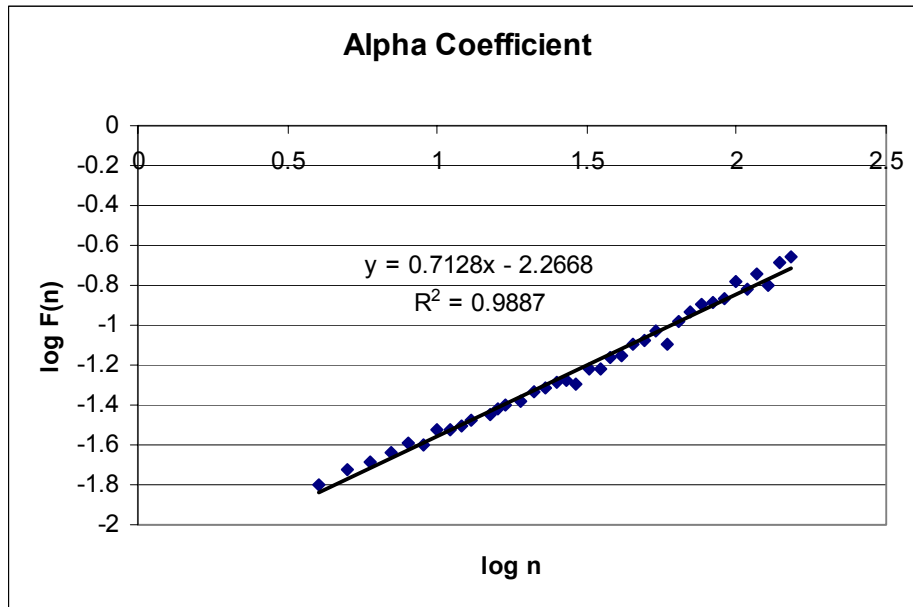

Figure 52: left foot with knee pads

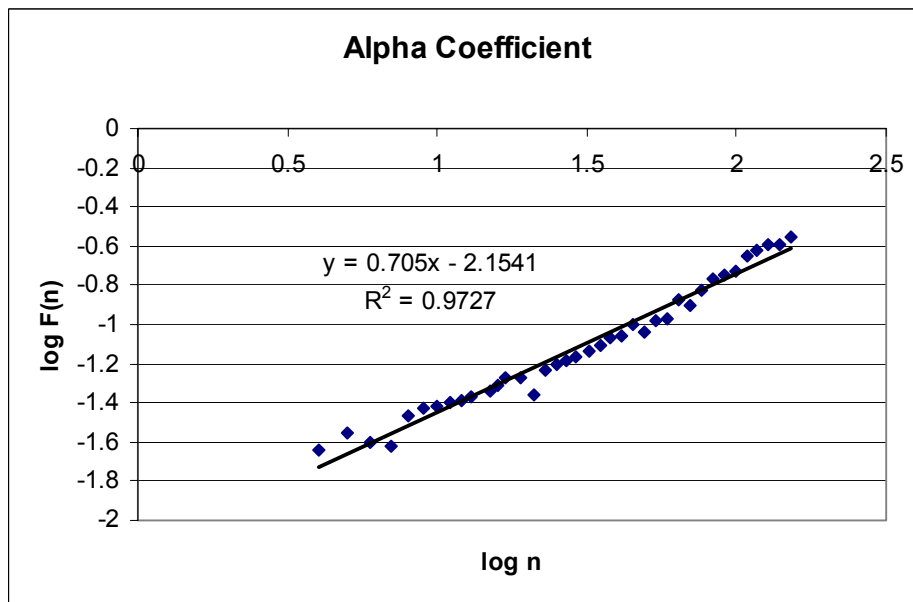

Figure 53: left foot without knee pads

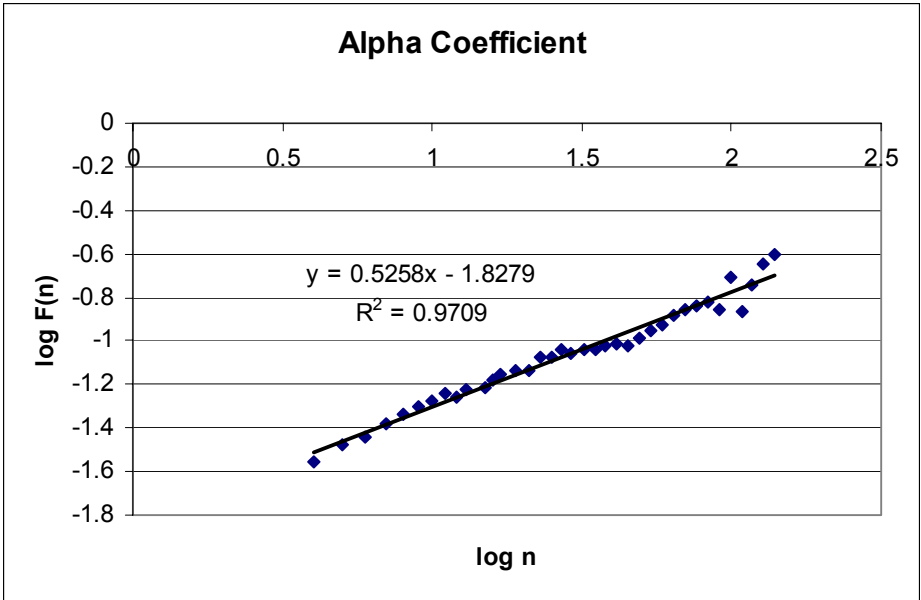

Figure 54: right foot with knee pads

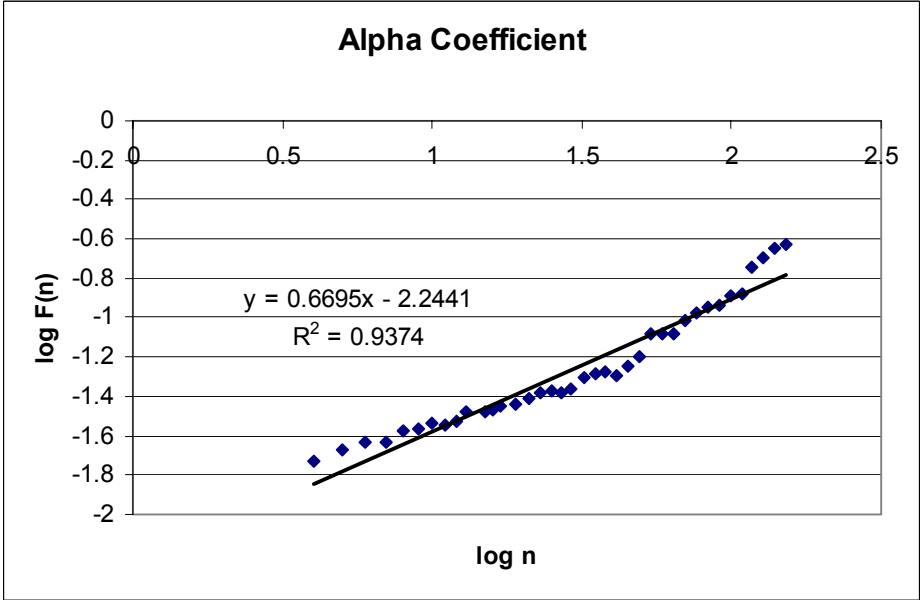

Figure 55: right foot without knee pads

## APPENDIX D: Pressure Results For Subjects after filtering

Subject 1:

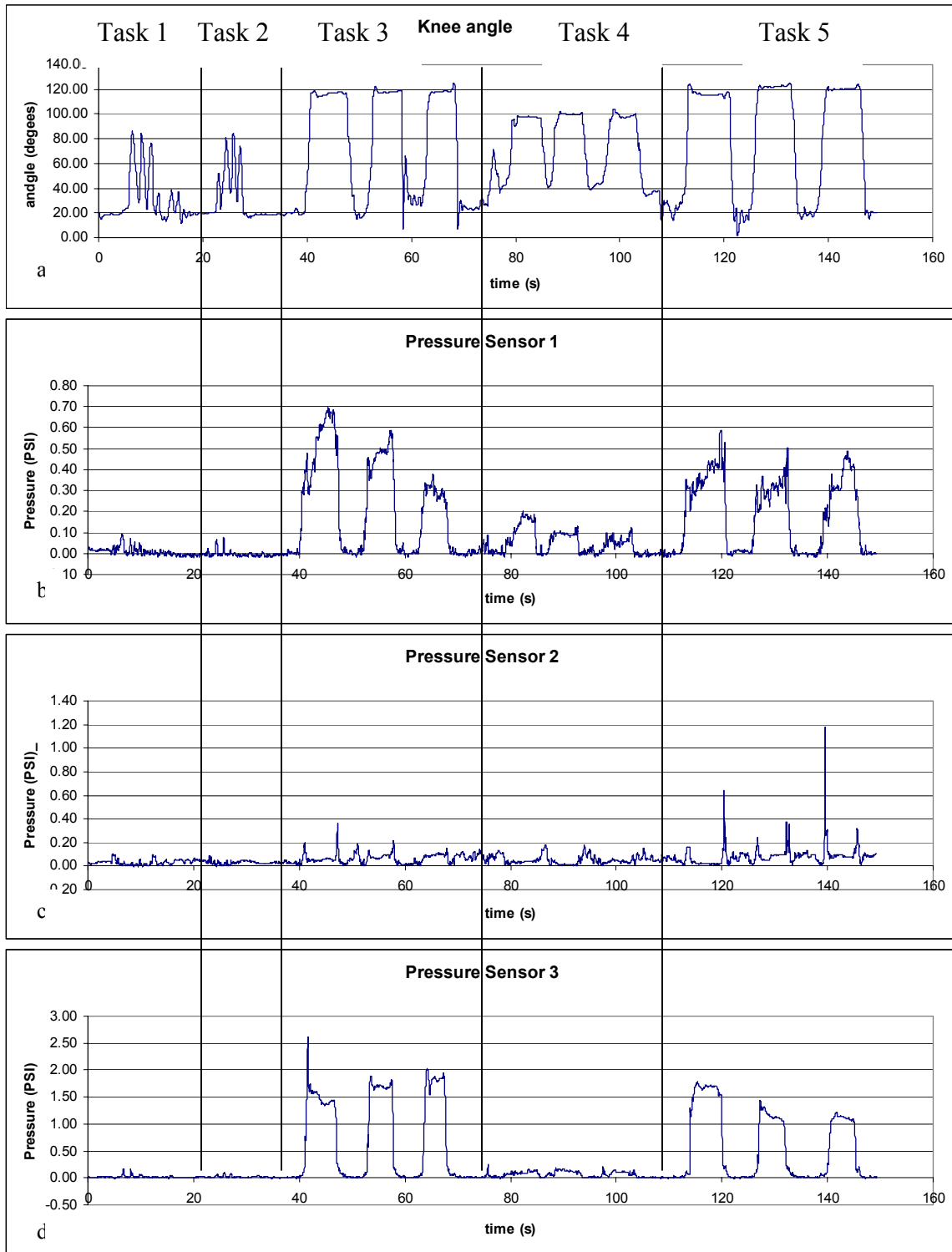

Figure 56: Pressure results for subject 1: (a) knee angle, (b) sensor 1, (c) sensor 2, (d) sensor 3

Subject 2:

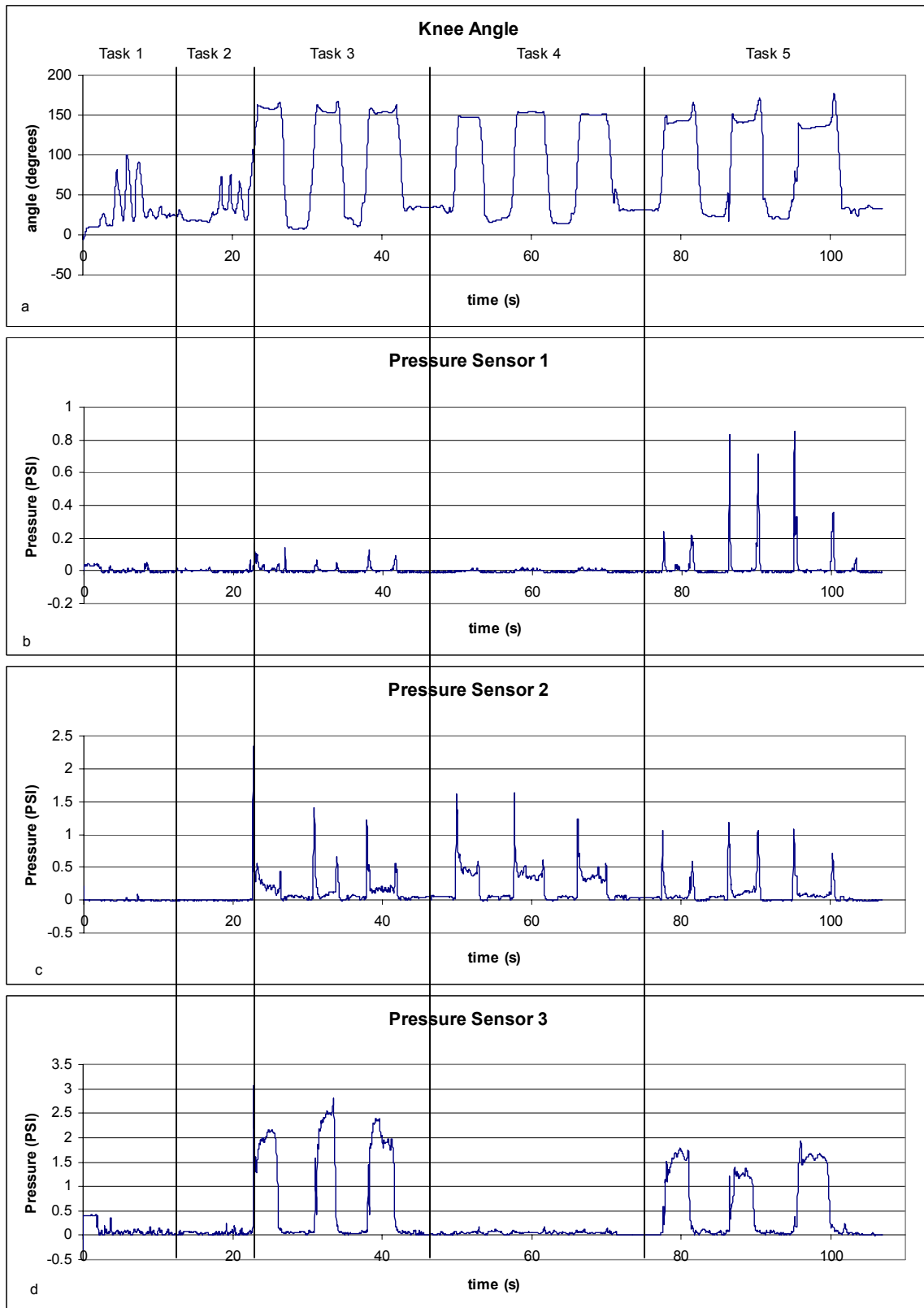

Figure 57: Pressure results for subject 2: (a) knee angle, (b) sensor 1, (c) sensor 2, (d) sensor 3

Subject 3:

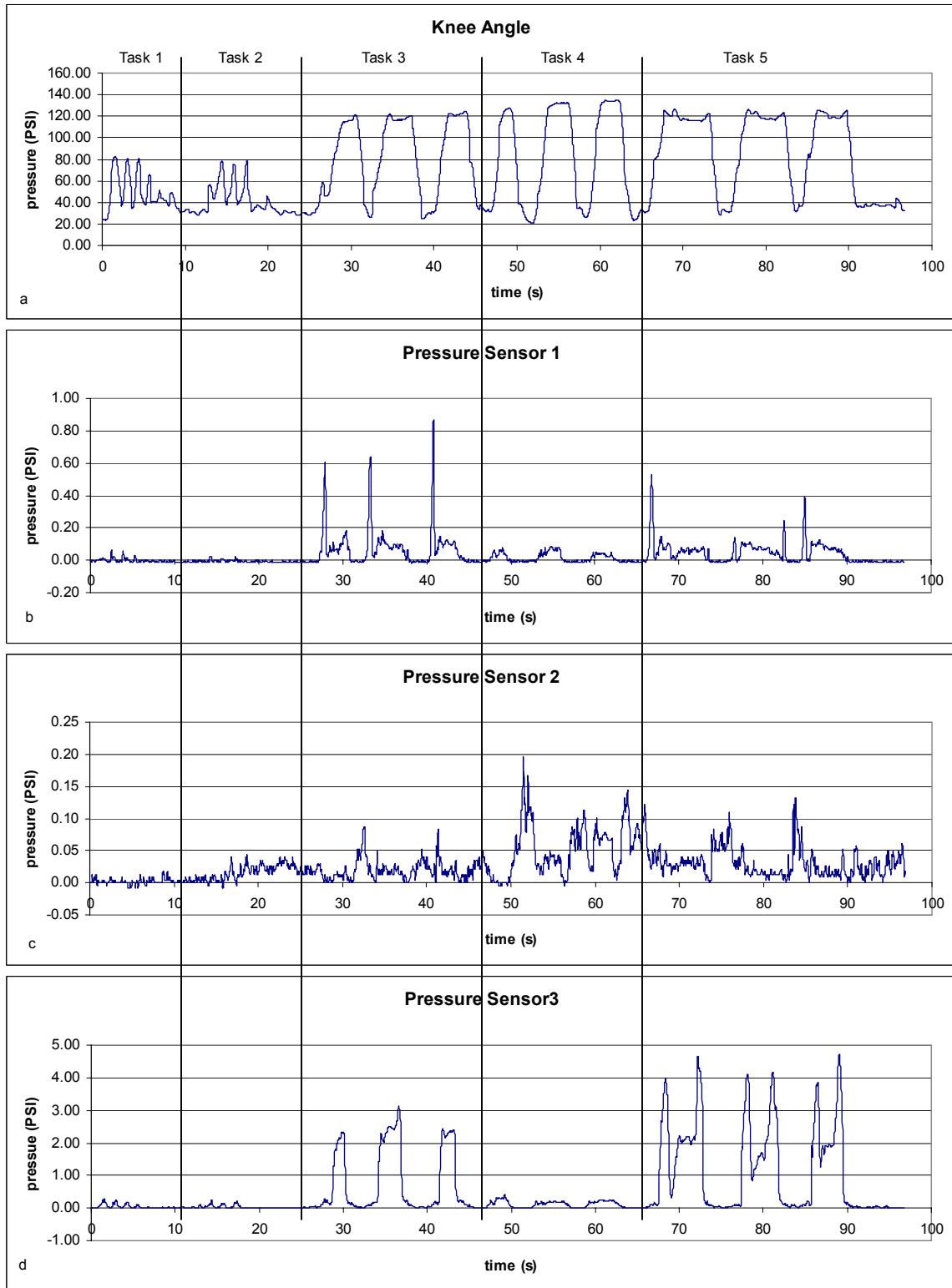

Figure 58: Pressure results for subject 3: (a) knee angle, (b) sensor 1, (c) sensor 2, (d) sensor 3

Subject 4:

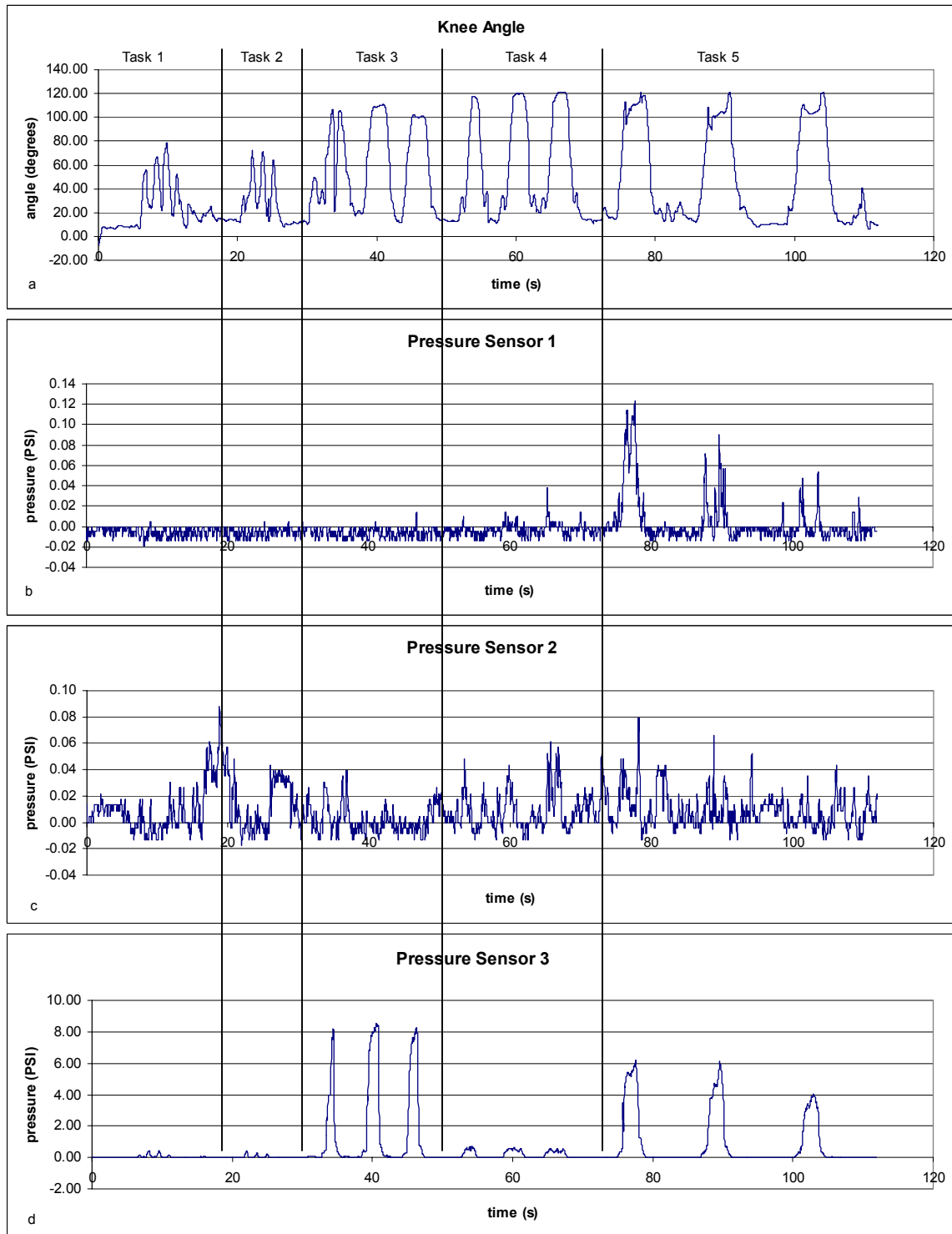

Figure 59: Pressure results for subject 4: (a) knee angle, (b) sensor 1, (c) sensor 2, (d) sensor 3

Subject 5:

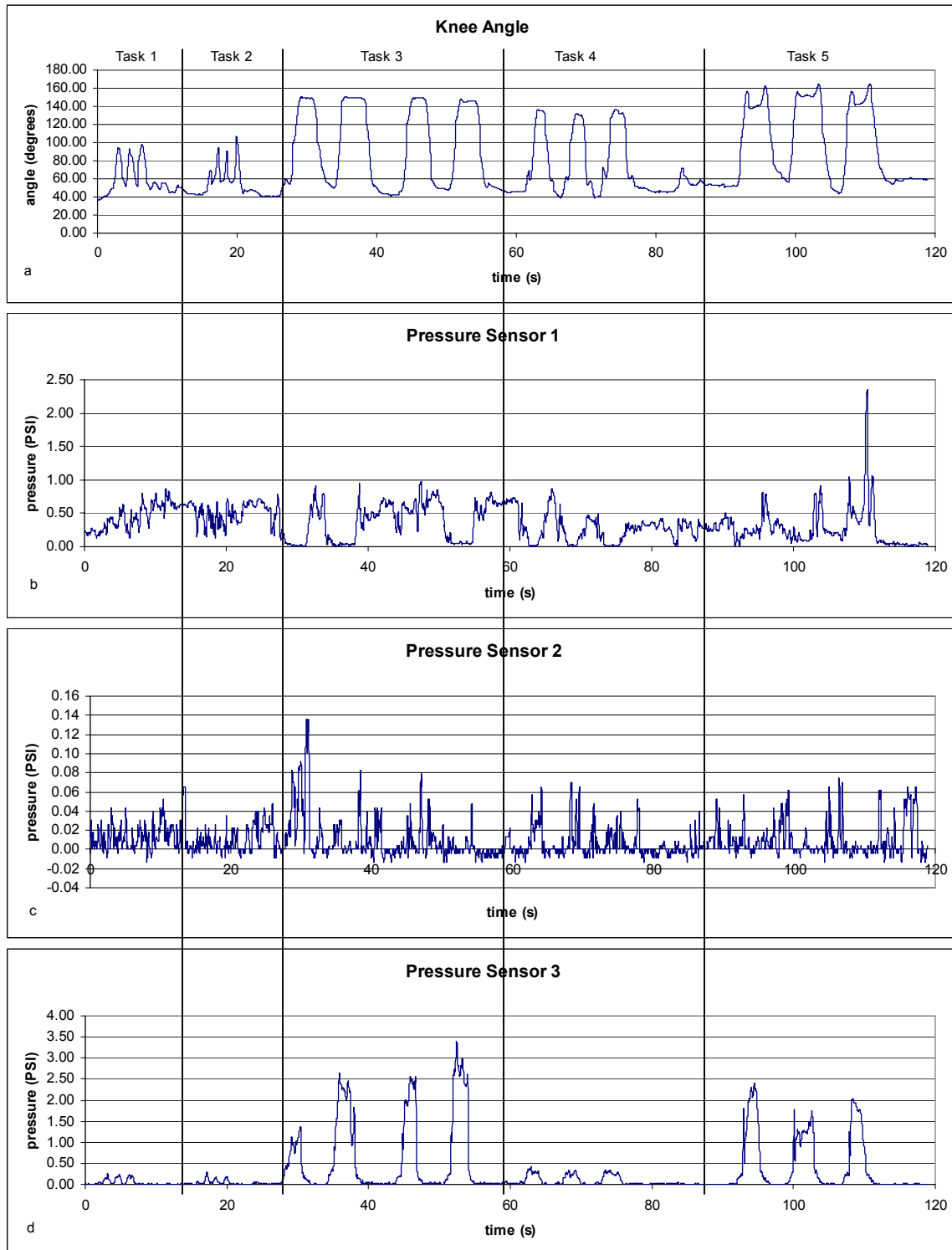

Figure 60: : Pressure results for subject 5: (a) knee angle, (b) sensor 1, (c) sensor 2, (d) sensor 3

Subject 6:

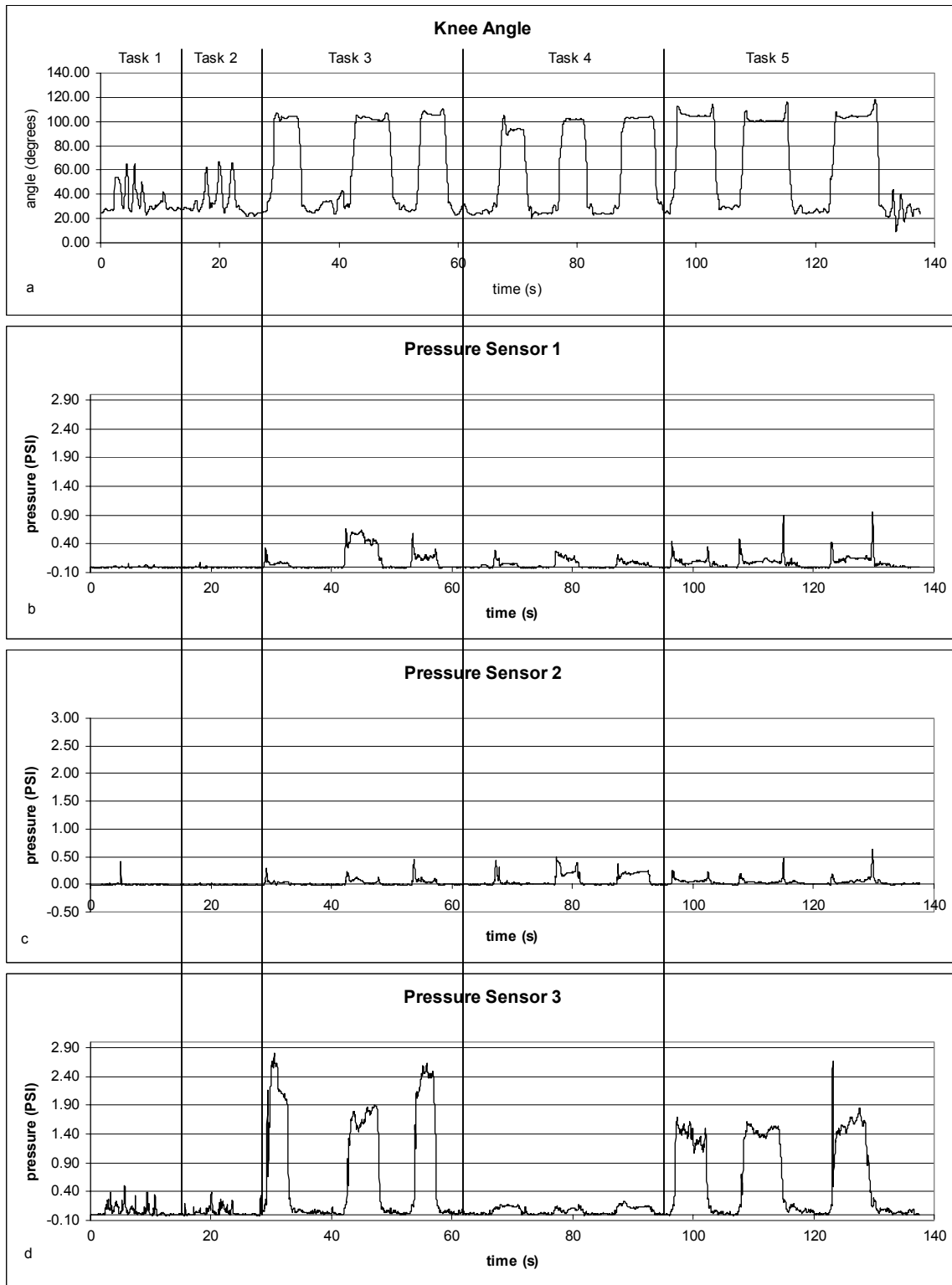

Figure 61: Pressure results for subject 6: (a) knee angle, (b) sensor 1, (c) sensor 2, (d) sensor 3

**APPENDIX E: Survey Results**

Subject 1 Foot wear: athletic shoe

1. Did the kneepads stay properly attached to your knees during movement?

YES NO

If NO, please explain.

The right knee pad only stayed on after it was laced much tighter than the left one.

2. Did the kneepad restrict your range of motion?

YES NO

If YES, please explain.

They did not allow full extension of my lower legs.

3. Did the kneepad restrict your circulation?

YES NO

If YES, please explain.

4. Did the kneepad fit properly?

YES NO

If NO, please explain.

5. Using the scale provided, please rate the kneepad for the following criteria. Circle ONE number for each. If you can not answer for a particular item, circle "N/A."

	UNCOMFORTABLE	MODERATE	NEITHER	MODERATE	COMFORTABLE	
	1	2	3	4	5	
a. Comfort when kneeling	N/A	1	2	3	4	5
b. Comfort when prone	N/A	1	2	3	4	5
c. Comfort when walking	N/A	1	2	3	4	5
d. Comfort when standing	N/A	1	2	3	4	5
e. Comfort overall	N/A	1	2	3	4	5

Comments?

6. Did you experience any binding or discomfort from the kneepad?

**YES**

NO

If YES, please indicate where.



Upon kneeling the straps shift towards the back of the knee loading an uncomfortable pressure there.

Subject 2 Foot wear: casual shoe

**Follow up Survey:**

1. Did the kneepads stay properly attached to your knees during movement?

**YES** NO

If NO, please explain.

2. Did the kneepad restrict your range of motion?

**YES** NO

If YES, please explain.

I felt like I couldn't bend down as much as normal

3. Did the kneepad restrict your circulation?

YES **NO**

If YES, please explain.

4. Did the kneepad fit properly?

**YES** NO

If NO, please explain.

5. Using the scale provided, please rate the kneepad for the following criteria. Circle ONE number for each. If you can not answer for a particular item, circle "N/A."

UNCOMFORTABLE	MODERATE	NEITHER	MODERATE	COMFORTABLE		
1	2	3	4	5		
a. Comfort when kneeling	N/A	1	2	3	<b>4</b>	5
b. Comfort when prone	N/A	1	2	<b>3</b>	4	5
c. Comfort when walking	N/A	1	2	<b>3</b>	4	5
d. Comfort when standing	N/A	1	2	3	<b>4</b>	5
e. Comfort overall	N/A	1	2	3	<b>4</b>	5

Comments?

6. Did you experience any binding or discomfort from the kneepad?

YES

**NO**

If YES, please indicate where.



Subject 3 Foot wear: athletic shoe

**Follow up Survey:**

1. Did the kneepads stay properly attached to your knees during movement?

YES NO

If NO, please explain.

Top Velcro strap on right knee was not tight enough to hold knee pad on.

2. Did the kneepad restrict your range of motion?

YES NO

If YES, please explain.

3. Did the kneepad restrict your circulation?

YES NO

If YES, please explain.

4. Did the kneepad fit properly?

YES NO

If NO, please explain.

5. Using the scale provided, please rate the kneepad for the following criteria. Circle ONE number for each. If you can not answer for a particular item, circle "N/A."

	UNCOMFORTABLE	MODERATE	NEITHER	MODERATE	COMFORTABLE		
	1	2	3	4	5		
a. Comfort when kneeling		N/A	1	2	3	4	5
b. Comfort when prone		N/A	1	2	3	4	5
c. Comfort when walking		N/A	1	2	3	4	5
d. Comfort when standing		N/A	1	2	3	4	5
e. Comfort overall		N/A	1	2	3	4	5

Comments?

Just make it stay on better and it'd be a great product.

6. Did you experience any binding or discomfort from the kneepad?

YES

**NO**

If YES, please indicate where.



Subject 4 Foot wear: athletic shoe

**Follow up Survey:**

1. Did the kneepads stay properly attached to your knees during movement?

YES NO

If NO, please explain.

2. Did the kneepad restrict your range of motion?

YES NO

If YES, please explain.

3. Did the kneepad restrict your circulation?

YES NO

If YES, please explain.

4. Did the kneepad fit properly?

YES NO

If NO, please explain.

It was a bit small for my knee

5. Using the scale provided, please rate the kneepad for the following criteria. Circle ONE number for each. If you can not answer for a particular item, circle "N/A."

UNCOMFORTABLE	MODERATE	NEITHER	MODERATE	COMFORTABLE		
1	2	3	4	5		
a. Comfort when kneeling	N/A	1	2	3	4	5
b. Comfort when prone	N/A	1	2	3	4	5
c. Comfort when walking	N/A	1	2	3	4	5
d. Comfort when standing	N/A	1	2	3	4	5
e. Comfort overall	N/A	1	2	3	4	5

Comments?

6. Did you experience any binding or discomfort from the kneepad?

**YES**

NO

If YES, please indicate where.



because I didn't fasten it correctly.

Subject 5 Foot wear: athletic shoe

**Follow up Survey:**

1. Did the kneepads stay properly attached to your knees during movement?

**YES** NO

If NO, please explain.

2. Did the kneepad restrict your range of motion?

YES **NO**

If YES, please explain.

3. Did the kneepad restrict your circulation?

YES **NO**

If YES, please explain.

4. Did the kneepad fit properly?

**YES** NO

If NO, please explain.

5. Using the scale provided, please rate the kneepad for the following criteria. Circle ONE number for each. If you can not answer for a particular item, circle "N/A."

UNCOMFORTABLE	MODERATE	NEITHER	MODERATE	COMFORTABLE		
1	2	3	4	5		
a. Comfort when kneeling	N/A	1	<b>2</b>	3	4	5
b. Comfort when prone	N/A	1	2	3	4	5
c. Comfort when walking	N/A	1	2	3	<b>4</b>	5
d. Comfort when standing	N/A	1	2	3	4	<b>5</b>
e. Comfort overall	N/A	1	2	3	<b>4</b>	5

Comments?

6. Did you experience any binding or discomfort from the kneepad?

YES

**NO**

If YES, please indicate where.



Subject 6 Foot wear: athletic shoe

**Follow up Survey:**

1. Did the kneepads stay properly attached to your knees during movement?

YES NO

If NO, please explain.

2. Did the kneepad restrict your range of motion?

YES NO

If YES, please explain.

3. Did the kneepad restrict your circulation?

YES NO

If YES, please explain.

4. Did the kneepad fit properly?

YES NO

If NO, please explain.

Knee pad was a bit on the large size. Straps had to be pulled as tight as possible.

5. Using the scale provided, please rate the kneepad for the following criteria. Circle ONE number for each. If you can not answer for a particular item, circle "N/A."

	UNCOMFORTABLE	MODERATE	NEITHER	MODERATE	COMFORTABLE		
	1	2	3	4	5		
a. Comfort when kneeling		N/A	1	2	3	4	5
b. Comfort when prone		N/A	1	2	3	4	5
c. Comfort when walking		N/A	1	2	3	4	5
d. Comfort when standing		N/A	1	2	3	4	5
e. Comfort overall		N/A	1	2	3	4	5

Comments?

Knee pads were very comfortable. They didn't restrict motion. No running or any type of hard physical activity was involved.

6. Did you experience any binding or discomfort from the kneepad?

YES

**NO**

If YES, please indicate where.



**APPENDIX F: Informed Consent Form**

**Informed Consent**

**Title:** Effects of Kneepads on Gait and Comfort

**Principle Investigators:** Thomas Castagno

**Date:** \_\_\_\_\_

**Sponsor:** US Army Soldier Center

**Research Subjects Name:** \_\_\_\_\_ **Date:** \_\_\_\_\_

**Purpose of Research:**

The goal of this research to measure the force the kneepad exerts on the knee during different activities and determine if the kneepad has any effects on long term gait correlations. The kneepad being tested is issued by the U.S. Army and an identical version is commercially available. To measure the force the kneepad exerts on the knee pressure sensors will be attached to the knee under the kneepad in three different locations; one on the bottom of the patella, one on the tendon on the back of the knee above the joint under the top strap, and one on the calf under the bottom strap. A goniometer will also be placed on the left knee to under the kneepad to measure knee angle. To measure gait to footswitches will be taped to the inner sole of the boot to determine the heel strike time interval.

**Your Rights:**

It is important for you to understand that your participation is entirely voluntary. You may decide not to take part or decide to quite the study at any time, without any penalty. You will be told about any new information of changes in the study that might affect your participation.

**Description of the Experiment:**

The knee goniometer and the force sensors are held in place by tape cause some discomfort during the experiment and during removal of the sensors. The kneepad itself may cause mild discomfort during the different activities and fatigue may arise during the gait session. All of the sensors are fed into a data acquisition card in a laptop computer carried by the experimenter so the subject will not have to carry any loads.

**Saefty:**

The knee pad does exert a force on the knee and the person is asked walk around and go to a kneeling position while the sensors and kneepads are attached to them. There does exist a minimal possibility of accidental tripping over the wires between the sensors and the computer.

**I hereby voluntary to participate in this study.**

---

**Participants Signature** \_\_\_\_\_ **Date** \_\_\_\_\_

---

**Witnessed by** \_\_\_\_\_ **Date** \_\_\_\_\_

## APPENDIX G: Signal filtering

The signal recorded from the data acquisition system for the foot switches was rounded off to a tenth of a volt at the time of recording (Figure 62).

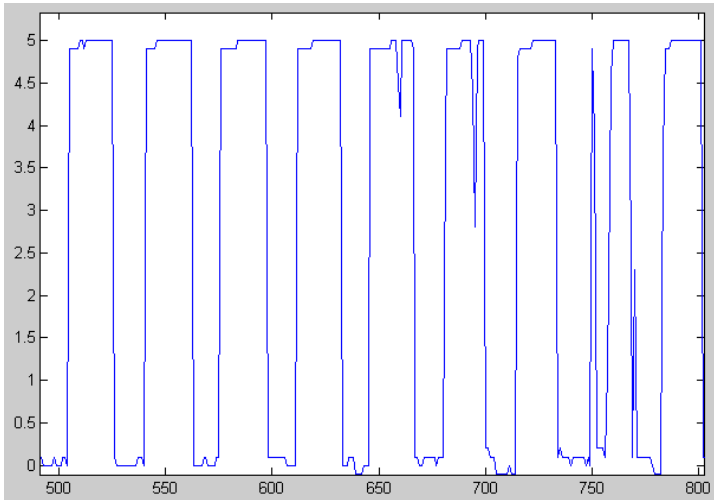

**Figure 62: Signal recorded from DAQ system**

This signal was then converted into a binary signal (Figure 63) by setting a threshold voltage of 0.7 volts.

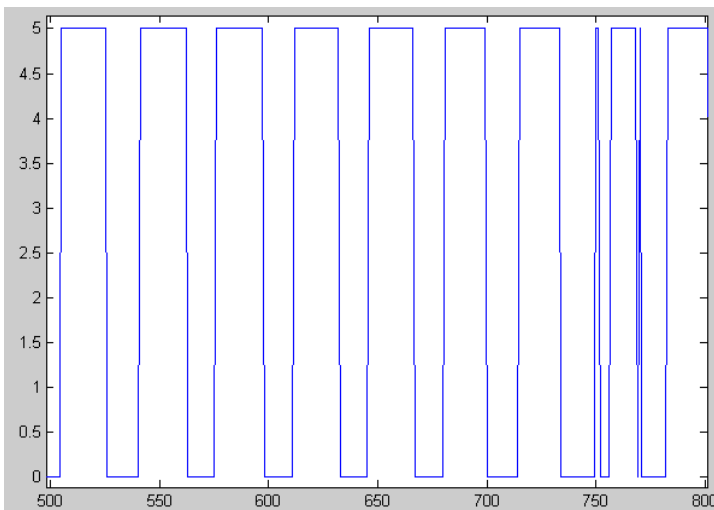

**Figure 63: Binary time signal**

An averaging filter was then used on the data to help eliminate unwanted peaks in the data (Figure 64).

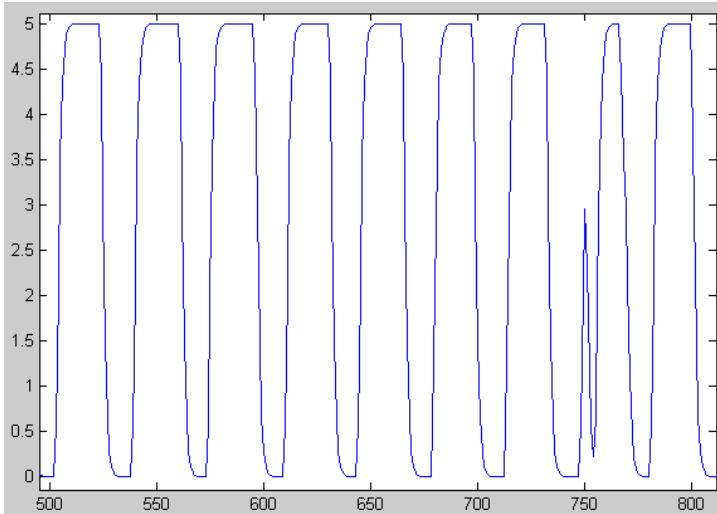

**Figure 64: Time signal after averaging filter**

A threshold voltage is then set to turn the signal back into a binary signal (Figure 65).

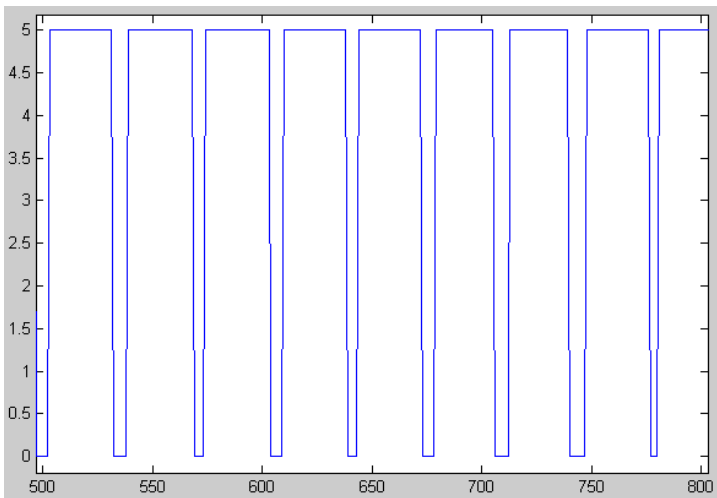

**Figure 65: Filtered time signal**

From this time signal an edge detection is run and the stride interval time signal is created (Figure 66).

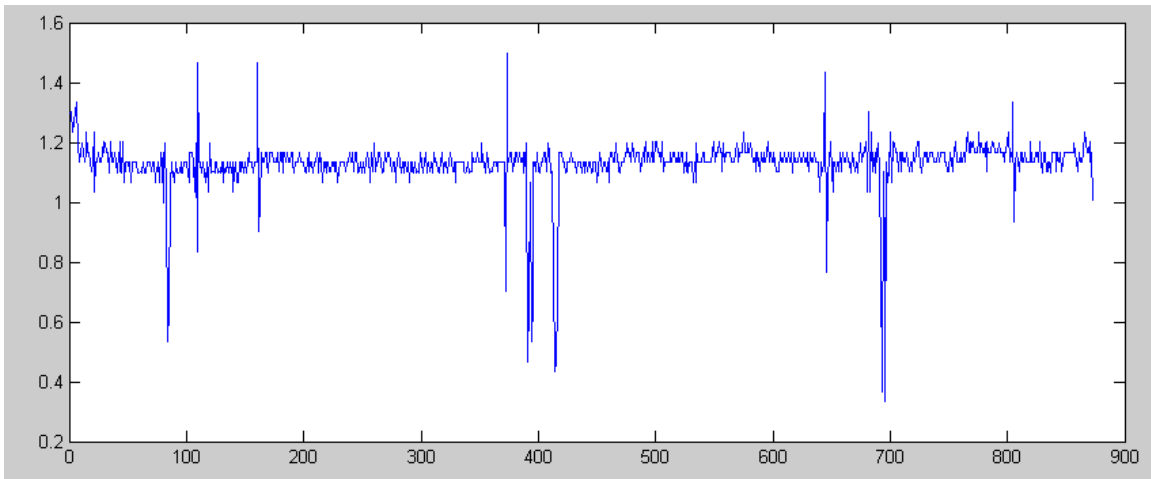

**Figure 66: Initial stride interval time series**

This time series is then edited as described in Section 3.6.1, Figure 10 to create the final stride interval time series (Figure 67).

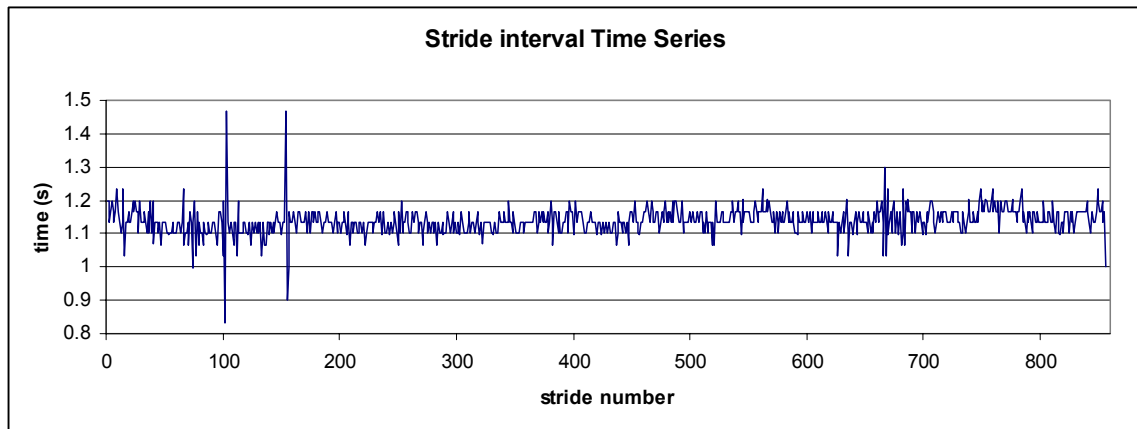

**Figure 67: Final stride interval time series**

## APPENDIX H: Detrended Fluctuation Analysis

The first step is to start with the stride interval time series  $I(i)$  (shown for subject 2, left foot with knee pads) seen in Figure 68.

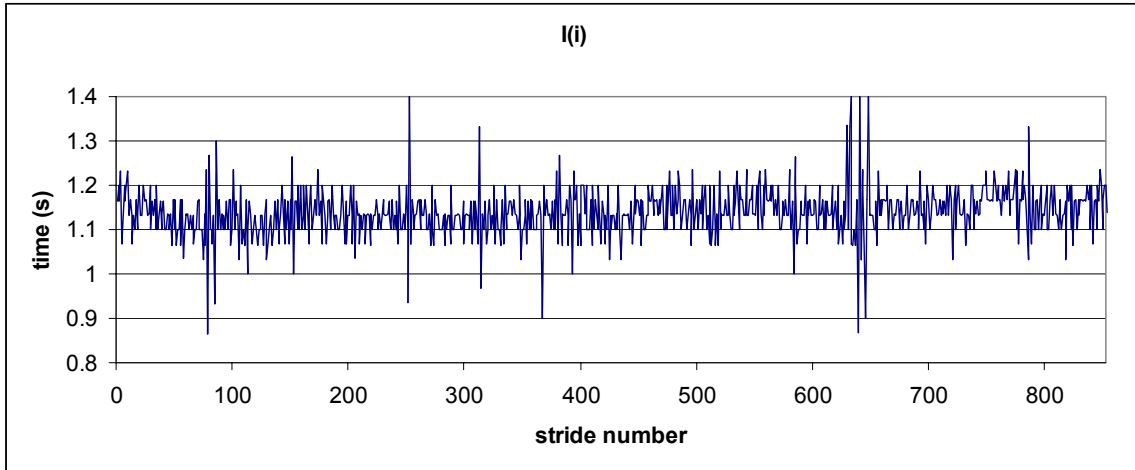

Figure 68: Stride Interval

Equation 2-1 is then applied to the time series where  $I_{ave} = 1.139$  seconds to create the integrated time series  $y(k)$  (Figure 69). Table 14 illustrates a sample of the time signal analyzed to create the time series.

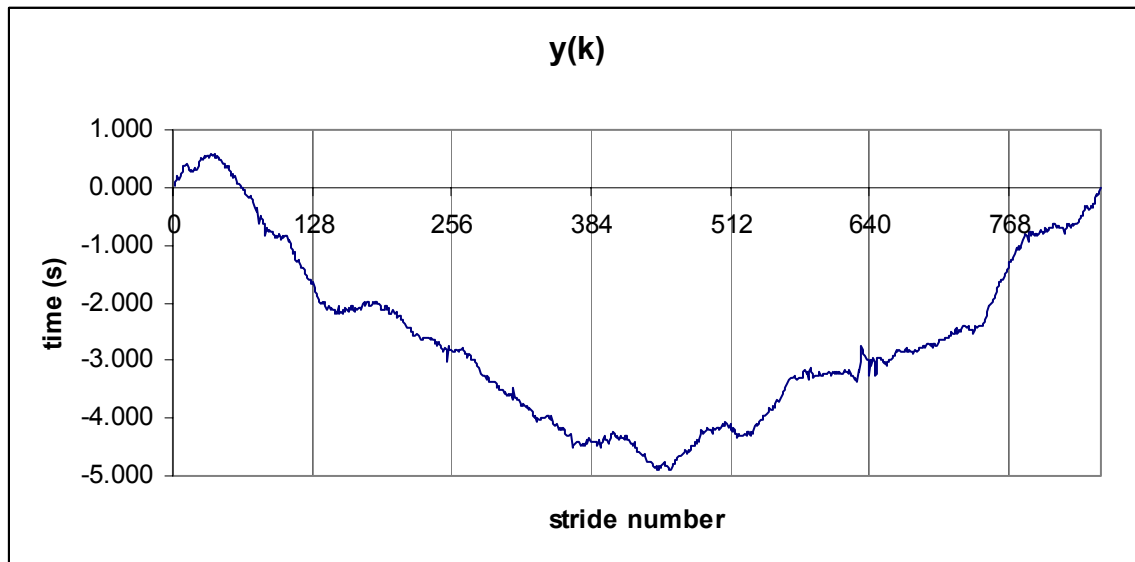

Figure 69: Integrated time series

l(i)	y(k)
1.166	0.027
1.201	0.090
1.166	0.117
1.233	0.212
1.067	0.140
1.134	0.136
1.2	0.197
1.166	0.224
1.201	0.287
1.233	0.381
1.133	0.376
1.167	0.404
1.133	0.399
1.067	0.327
1.133	0.321
1.1	0.283
1.167	0.311
1.099	0.272
1.134	0.267
1.2	0.329
1.133	0.323
1.133	0.317
1.201	0.380
1.2	0.441
1.166	0.469
1.167	0.497
1.133	0.492
1.134	0.487
1.199	0.548

**Table 14: Integrated time signal**

The integrated time series is then broken down into boxes of equal length samples  $n$ , in Figure 69,  $n = 128$ . Within each box a best fit line is created and the y-intercept for the line is designated by  $y_n(k)$  for each box, Figure 70 shows the best fit line and y-intercept for one of the boxes.

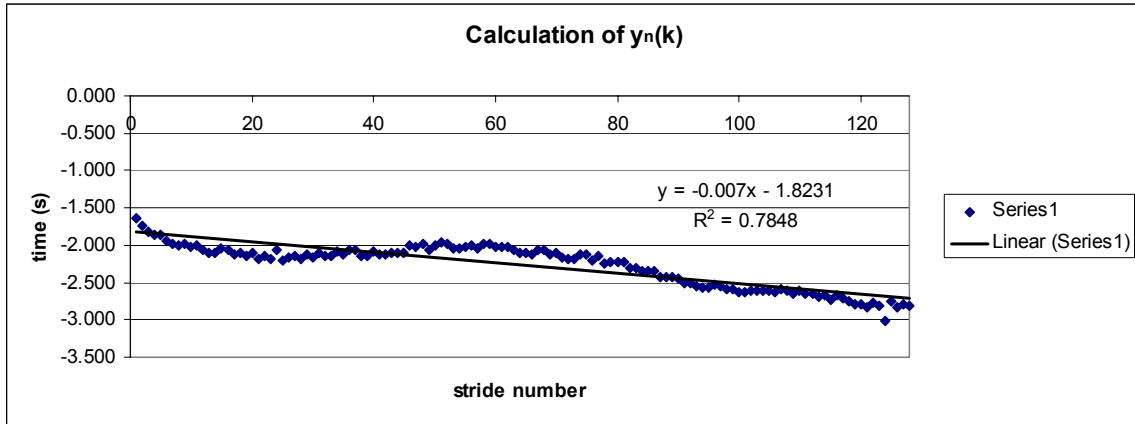

Figure 70: Calculation of  $y_n(k)$

The integrated time series is then detrended by subtracting  $y_n(k)$  from  $y(k)$  for each box (Table 15). For the box in Figure 70,  $y(k) - (-1.8321)$ .

$y(k)$	$y_n(k) =$
box 1	0.833
0.027	-0.806
0.090	-0.743
0.117	-0.716
0.212	-0.621
0.140	-0.693
0.136	-0.697
0.197	-0.636
0.224	-0.609
0.287	-0.546
0.381	-0.452
0.376	-0.457
0.404	-0.429
0.399	-0.434
0.327	-0.506
0.321	-0.512
0.283	-0.550
0.311	-0.522
0.272	-0.561
0.267	-0.566
0.329	-0.504
0.323	-0.510
0.317	-0.516
0.380	-0.453
0.441	-0.392
0.469	-0.364
0.497	-0.336

**Table 15: Detrended time signal**

The root mean square value is then calculated for the time series, as seen in equation 2-2.

This value then becomes  $F(n)$  for that value of  $n$ . this process is then repeated for all values of  $n$ , typical values are from  $n = 4$  to 213 for this example. The  $F(n)$  and  $n$  values are plotted on a log-log graph and the slope of the linear best fit line is the alpha coefficient.