

Agile Event-based Flight through Cluttered Environments

Rohan Inamdar (RBE/CS), Evan Kaba (RBE), Colin Balfour (RBE)
 Advisors: Guanrui Li, Nitin J. Sanket

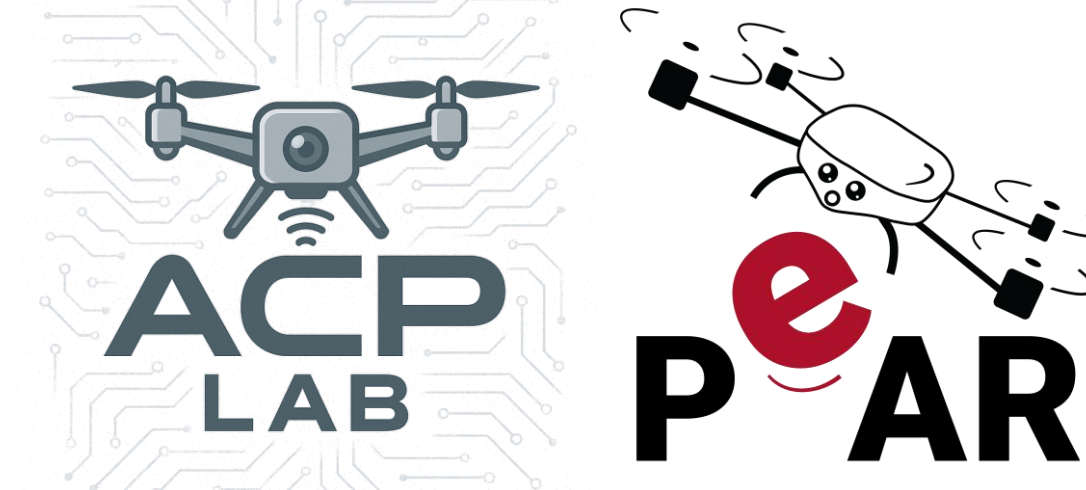

Motivation

- In search-and-rescue and anti-poaching, event cameras drive high-speed autonomous MAV navigation through high temporal resolution, high dynamic range, and low latency.
- Current systems are limited by bulky cameras, power capacity, and perception latency (1μs vs 33ms)

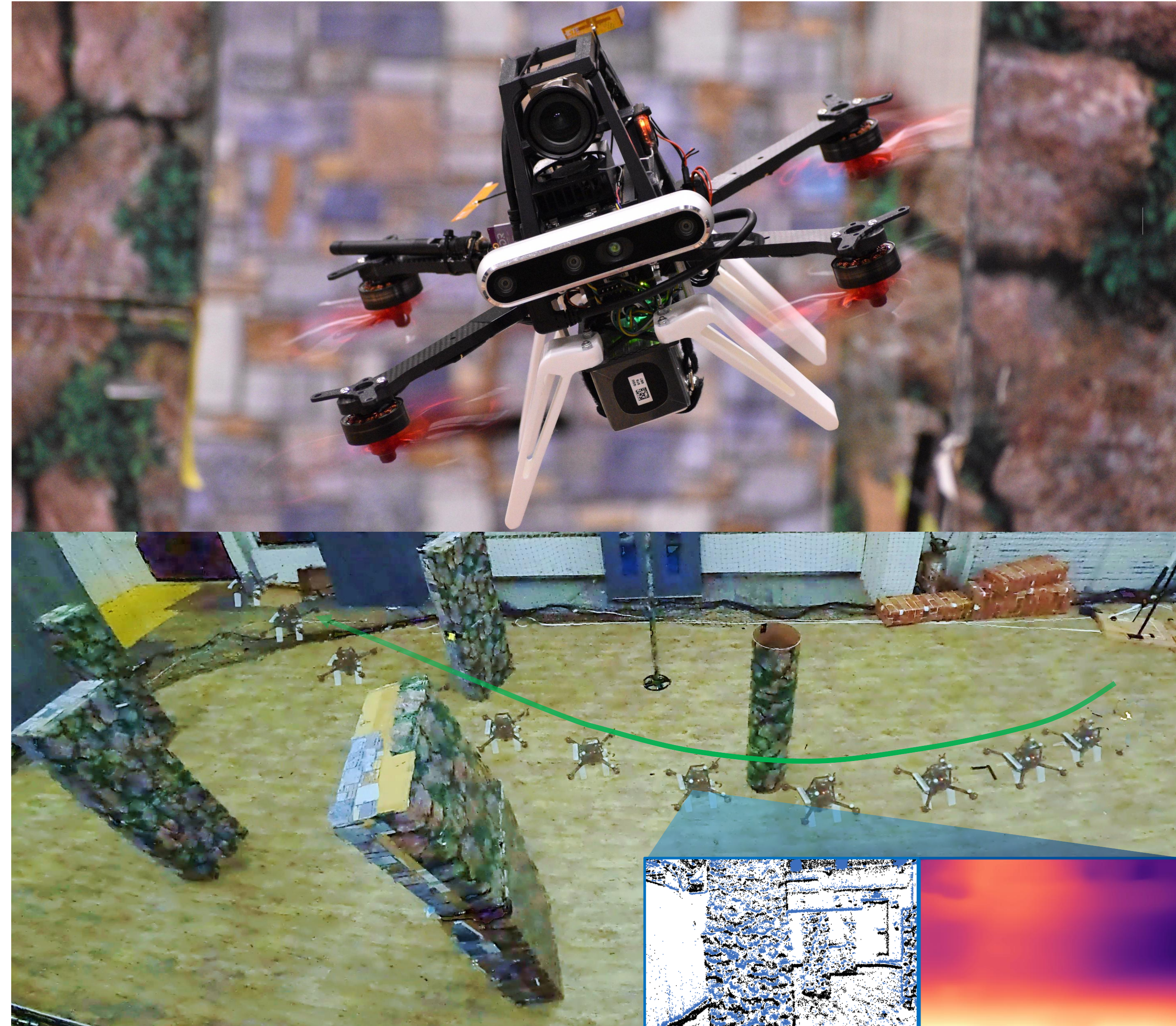

3D Design

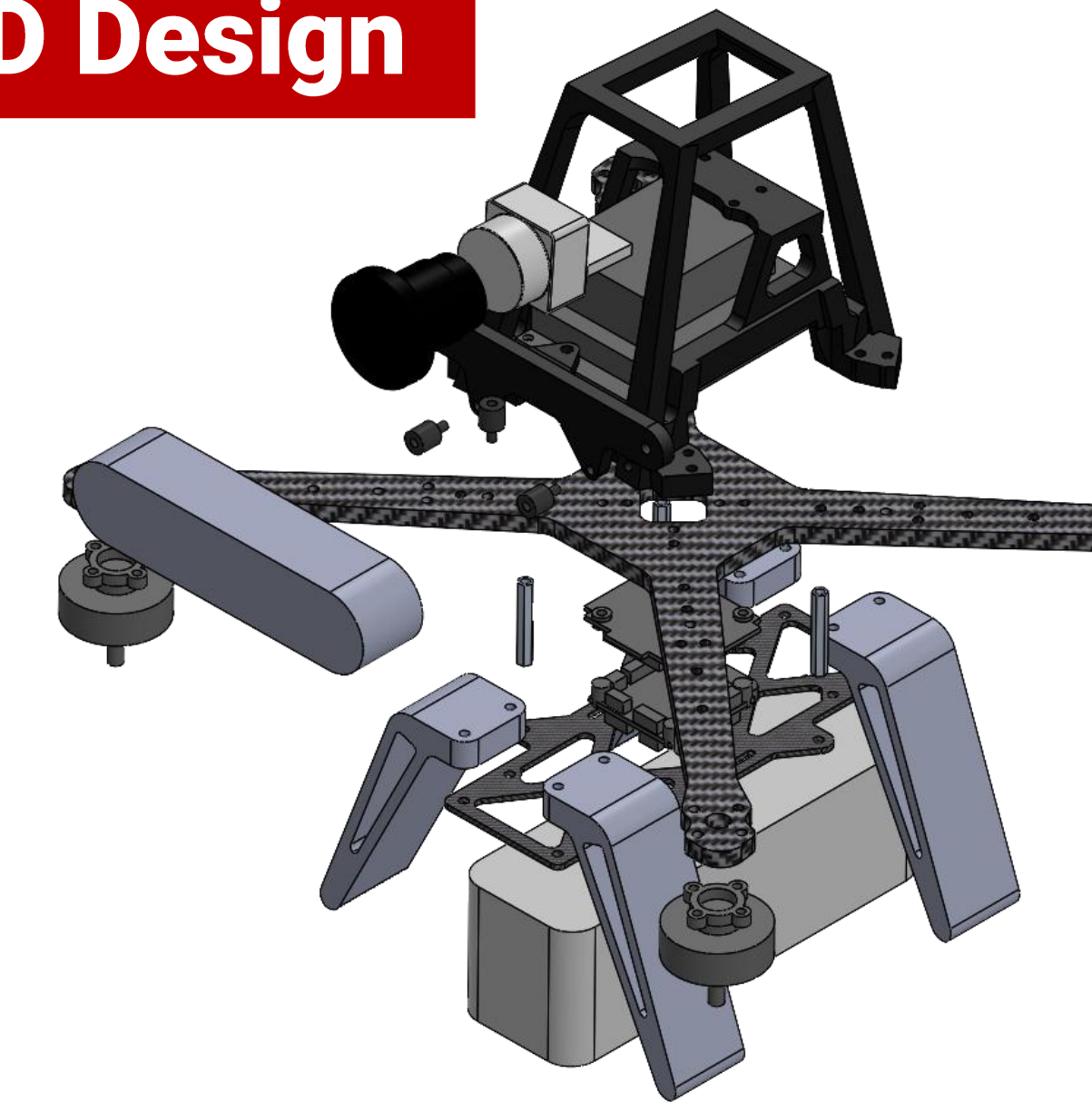

Technical Details

- We build ESDF maps using predicted depth from events and robot states
- We use a **kinodynamic trajectory optimizer** with ESDF maps and B-splines to generate smooth, collision-free trajectories.
- DQ-NMPC is a dual-quaternion nonlinear MPC that performs constraint-aware trajectory tracking on SE(3).

Event Stream

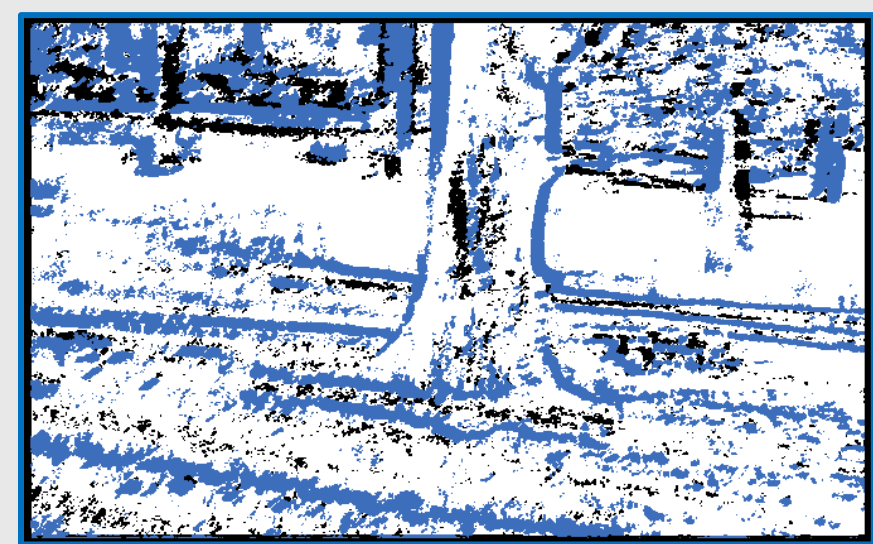

Event Camera Formulation

$$L(\mathbf{x}, t) = \log I(\mathbf{x}, t)$$

$$\Delta L(\mathbf{x}, t) = L(\mathbf{x}, t) - L(\mathbf{x}, t - \Delta t)$$

ON event: $\Delta L(\mathbf{x}, t) \geq C$

OFF event: $\Delta L(\mathbf{x}, t) \leq -C$

Depth Prediction (F³)

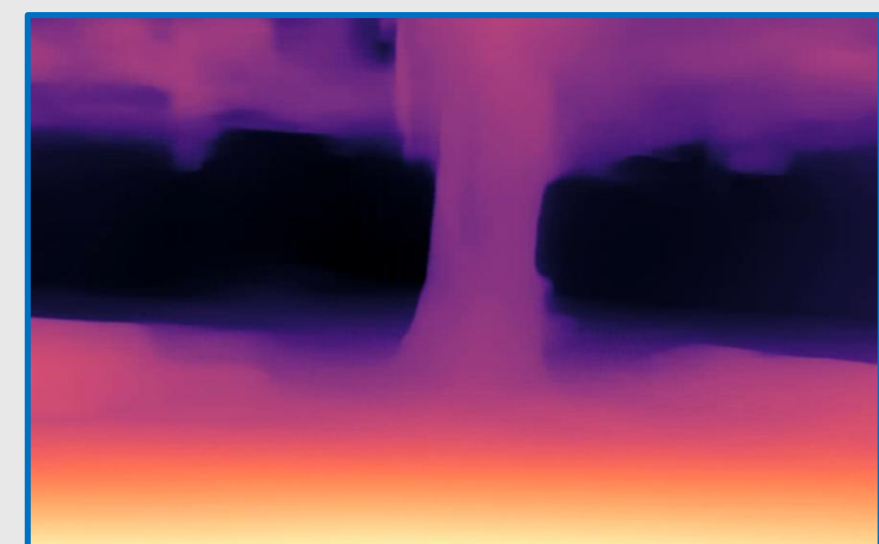

Deep Set Encoding

$$\underbrace{\Phi(\mathcal{E})}_{\text{set representation}} = \underbrace{\rho}_{\text{post-processing}} \left(\underbrace{\sum_{x \in \mathcal{E}} \psi(x)}_{\text{pool per-event features}} \right)$$

Perception

FastPlanner

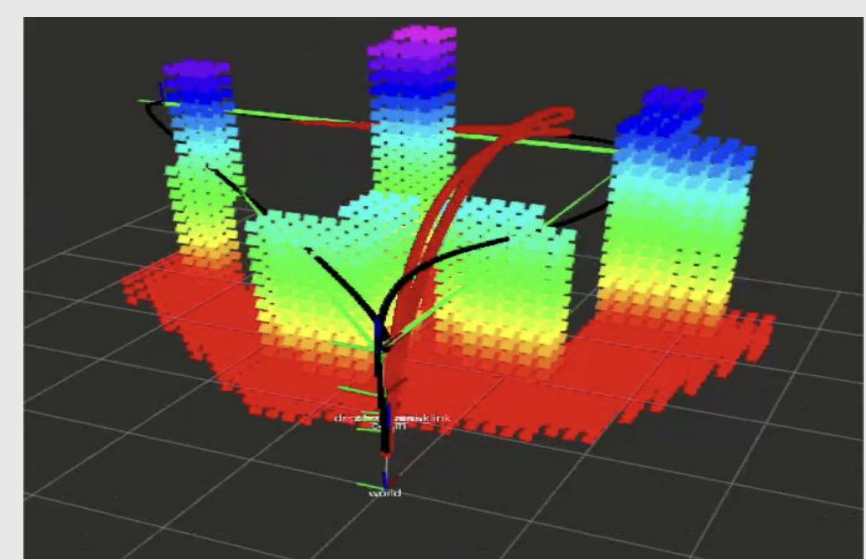

Kinodynamic Planner Cost Functions

$$x(t) = e^{At}x(0) + \int_0^t e^{A(t-\tau)}Bu(\tau) d\tau$$

$$\mathcal{J}(T) = \int_0^T \|u(t)\|^2 dt + \rho T$$

Planning & Control

DQ-NMPC

$[\tau_d, \Omega_d]$

Body-Rate Controller

$[f, w]$

Hardware Platform



Motion Capture



Visual Inertial Odometry



Event Camera Sensor

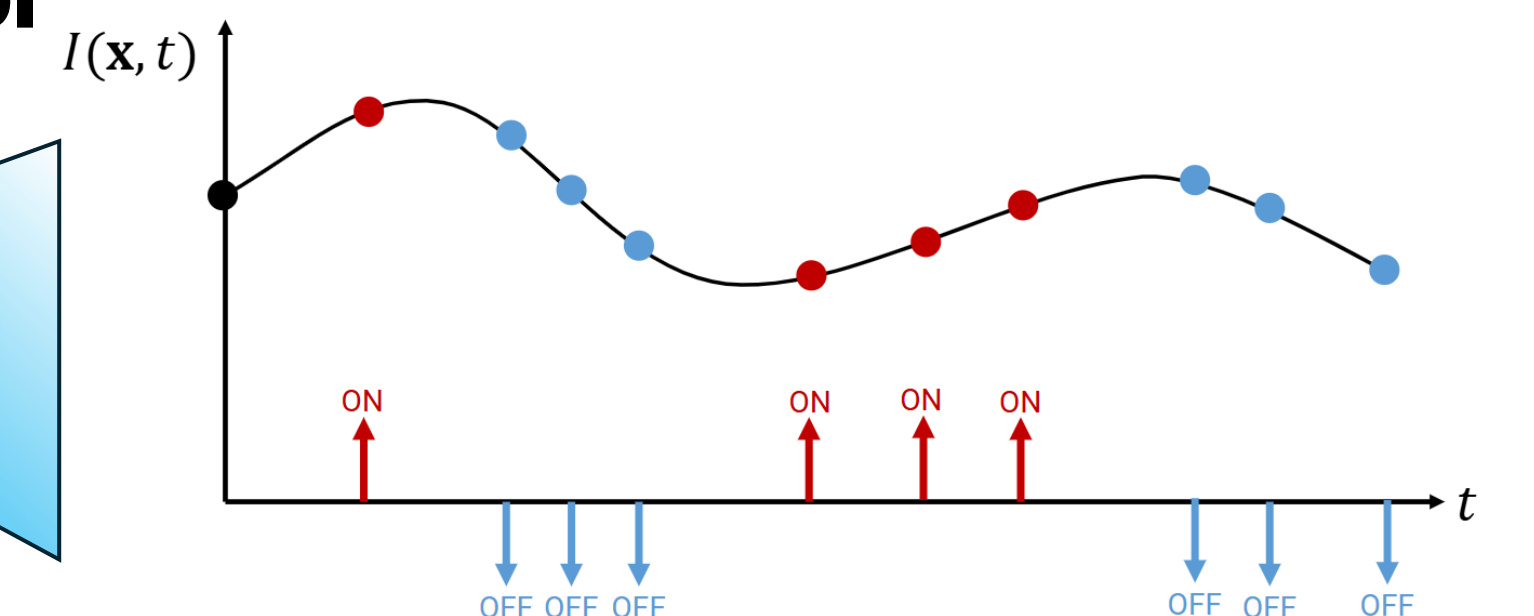
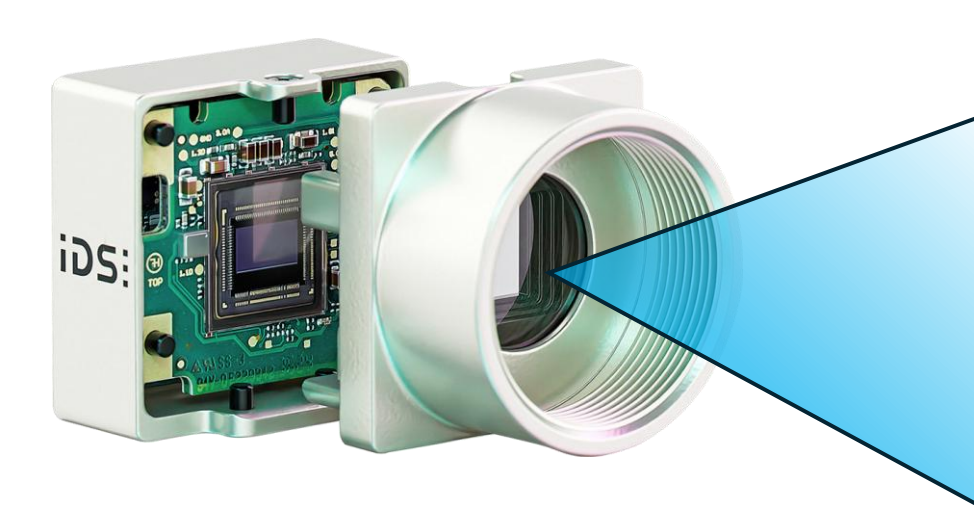

FastPlanner to DQ-NMPC Controller

